

Precision **Linear Motion Components** & Accessories

Product Guide **Metric Version**

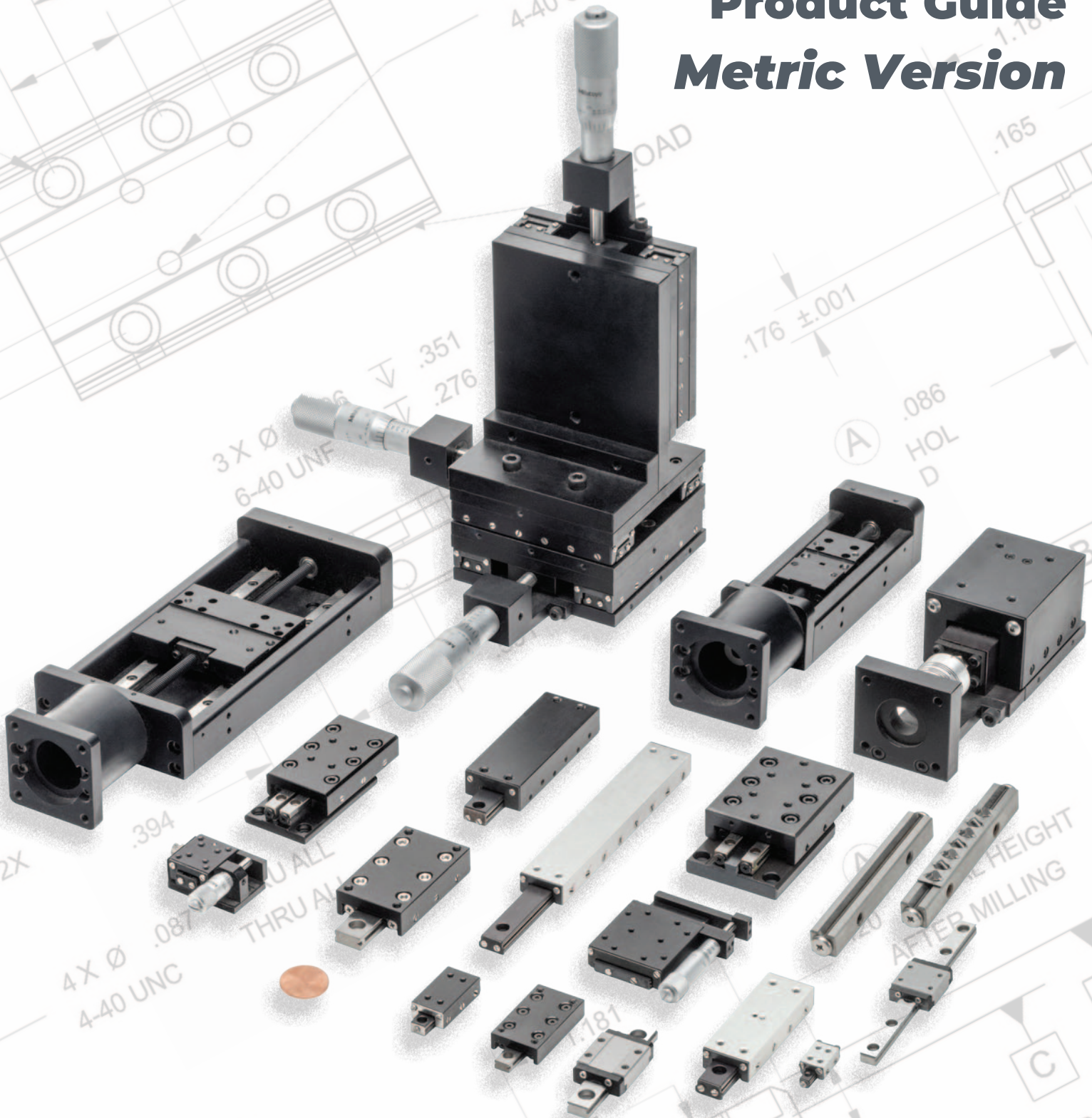

Our Mission

Del-Tron Precision was founded in order to serve the needs of automated equipment manufacturers for innovative, high quality and reasonably priced anti-friction linear bearings.

Our Company

The originator of the sub miniature ball bearing slide assembly; Del-Tron Precision Inc. began operations in 1974 supplying original equipment manufacturers with the world's first commercially available sub miniature ball slide, model D-1.

Since then, thousands of Del-Tron® slides have been incorporated into automated equipment throughout the world. Manufacturers of medical analyzing and testing machines, semiconductor and electronic chip processing equipment, printers, plotters, peripherals, assembly systems, lasers and many more have found that Del-Tron® slides provide a cost effective anti-friction interface between moving parts in today's increasingly automated equipment.

Del-Tron's modern corporate campus, home to world headquarters, and its principal manufacturing facility, located in the foothills of the Berkshires in Western Connecticut, boasts highly automated computer controlled manufacturing and assembly operations.

Highly skilled workers monitor each manufacturing step, ensuring that consistent and repeatable high quality bearings conform to the published specifications or the customer's particular requirements where applicable. Since its inception, Del-Tron has performed final inspection of 100% of its products.

Del-Tron's operations staff works to assure "just in time" deliveries, if needed, and maintains adequate stock levels of all products at authorized distributor locations in major markets across the U.S.A. and Canada. MHK serves as Del-Tron's European distribution hub in Amberg, Germany. The firm also has locations in Japan and throughout Southeast Asia stand ready to serve the needs of both local and indigenous industries and those of multinational assembly and manufacturing operations worldwide.

Our Quality Policy

We are dedicated to providing our customers with a product of consistent quality that conforms to our specifications and meets or exceeds customer expectations while making on-time delivery at a competitive price.



INDEX

<i>Selection Guide</i>	<i>P 4</i>
<i>Ball Slide Assemblies</i>	<i>P 7</i>
<i>Anti-Creep Ball Slide Assemblies</i>	<i>P 10</i>
<i>Non-Magnetic Ball Slide Assemblies</i>	<i>P 13</i>
<i>Crossed Roller Slide Assemblies</i>	<i>P 16</i>
<i>Precision Series (Ball & Crossed Roller Slides)</i>	<i>P 19</i>
<i>High Precision Series (Ball & Crossed Roller Slides)</i>	<i>P 22</i>
<i>Mini Posi-Drive™ Stages</i>	<i>P 27</i>
<i>Posi-Drive™ Stages</i>	<i>P 37</i>
<i>Ball Slide Positioning Stages (Micrometer Driven)</i>	<i>P 44</i>
<i>Crossed Roller Positioning Stages (Micrometer Driven)</i>	<i>P 50</i>
<i>Ball & Crossed Roller Positioning Stages (Side Drive Micrometer)</i>	<i>P 56</i>
<i>Low Profile Crossed Roller Slide Tables</i>	<i>P 62</i>
<i>Crossed Roller Rail Sets</i>	<i>P 65</i>
<i>Anti-Creep Crossed Roller Rail Sets</i>	<i>P 69</i>
<i>Crossed Roller Slide Tables (Aluminum)</i>	<i>P 72</i>
<i>Anti-Creep Crossed Roller Slide Tables (Aluminum)</i>	<i>P 75</i>
<i>Crossed Roller Slide Tables (Steel)</i>	<i>P 78</i>
<i>Recirculating Ball Slide Guides</i>	<i>P 81</i>
<i>Technical Section</i>	<i>P 86</i>

Selection Guide

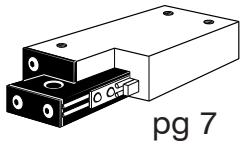

pg 7

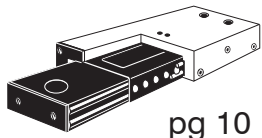

pg 10

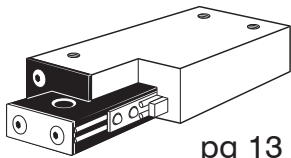

pg 13

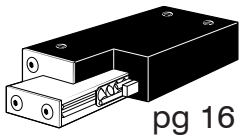

pg 16

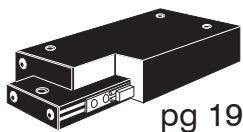

pg 19



pg 21

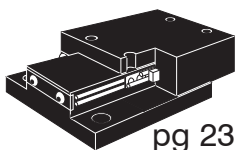

pg 23

BALL SLIDES

SERIES	LOAD CAPACITY, kg.	TRAVEL mm	LENGTH mm	ACCURACY
MINI CA	.34	8.4 - 38.0	13.3 - 44	0.013mm/25mm
DA-SA3 (50 MODELS)	1.8 - 93	13 - 304.0	27 - 381	0.013mm/25mm

ANTI-CREEP BALL SLIDE ASSEMBLIES

SERIES	LOAD CAPACITY, kg.	TRAVEL mm	LENGTH mm	ACCURACY
DA-AC-SA3-AC	1.8 - 93	13 - 304.0	27 - 381	0.013mm/25mm

NON-MAGNETIC BALL SLIDES

SERIES	LOAD CAPACITY, kg.	TRAVEL	LENGTH	ACCURACY
DA-NMS-SA3-NMS (47 MODELS)	.54 - 28	13 - 304.0	27 - 381	0.013mm/25mm

CROSSED ROLLER SLIDES

SERIES	LOAD CAPACITY, kg.	TRAVEL mm	LENGTH mm	ACCURACY
RDA	14 - 41	13.0 - 127.0	27.0 - 154.0	0.003mm/25mm
REA-RSA3 (47 MODELS)	22 - 354	13 - 305	27 - 381	0.003mm/25mm

PRECISION BALL SLIDE SERIES

SERIES	LOAD CAPACITY, kg.	TRAVEL mm	LENGTH mm	ACCURACY
MA-2SS-SA5-7SS (17 MODELS)	5.4 - 77	25 - 175.0	65 - 228.6	0.003mm/25mm

PRECISION CROSSED ROLLER SLIDE SERIES

SERIES	LOAD CAPACITY, kg.	TRAVEL mm	LENGTH mm	ACCURACY
RSA2SS-RSA5SS (12 MODELS)	36 - 118	25 - 175	50.8 - 228.6	0.003mm/25mm

HIGH PRECISION SERIES BALL SLIDES (LOW PROFILE & FLANGE BASE)

SERIES	LOAD CAPACITY, kg.	TRAVEL mm	LENGTH mm	ACCURACY
HPMA-HPSA5 (42 MODELS)	3.6 - 102	13 - 250	25.4 - 381.0	0.001mm/25mm

HIGH PRECISION SERIES CROSSED ROLLER SLIDES (LOW PROFILE & FLANGE BASE)

SERIES	LOAD CAPACITY, kg.	TRAVEL mm	LENGTH mm	ACCURACY
HPRSA2-HPRSA5 0.010mm/25mm (34 MODELS)	41 - 204	25 - 250	50.8 - 381.0	

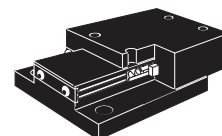

pg 25

POSI-DRIVE STAGES

SERIES	LOAD CAPACITY, kg.	TRAVEL mm	LENGTH mm	ACCURACY
LSA1-25-C005 THRU LSA3-300-B02 (36 MODELS)	3.6 - 41	25 - 300	103.4 - 549.0	0.003mm/25mm
LRSA1-25-C005 THRU LRSA3-300-B02 (36 MODELS)	6.8 - 82	25 - 300	103.4 - 549.0	0.003mm/25mm

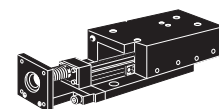

pg 27

BALL SLIDE POSITIONING STAGES (MICROMETER DRIVEN)

Available in X, XY, and XYZ configurations.

SERIES	LOAD CAPACITY, kg. X, XY, Z	TRAVEL mm	WORK SURFACE	ACCURACY
MINI 99MM	2.3, 2.3, .6	6	19.1 X 19.1	0.013mm/25mm
101MM-3204MM (25 MODELS, with micrometers)	1.8-27, 1.8-27, .6-14	13 - 50	31.8 x 31.8 to 130.2 x 130.2	0.013mm/25mm
101PMM-3206-PMM (11 MODELS, X and XY ONLY, no micrometers)	1.8 - 27	13 - 100	31.8 x 31.8 to 130.2 x 130.2	0.013mm/25mm

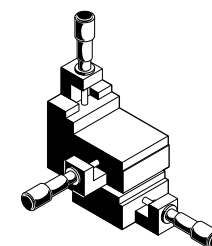

pg 44

CROSSED ROLLER POSITIONING STAGES (MICROMETER DRIVEN)

Available in X, XY, and XYZ configurations.

SERIES	LOAD CAPACITY, kg. X, XY, Z	TRAVEL mm	WORK SURFACE	ACCURACY
R99MM	18, 18, .57	6	19.1 x 19.1	0.003mm/25mm
R101MM-R3204MM (25 MODELS, with micrometers)	10-73, 10-73, .6-14	13 - 50	31.8 x 31.8 to 130.2 x 130.2	0.003mm/25mm
R101PMM-R3204PMM (11 MODELS, X and XY ONLY, no micrometers)	10 - 73	13 - 100	31.8 x 31.8 to 130.2 x 130.2	0.003mm/25mm

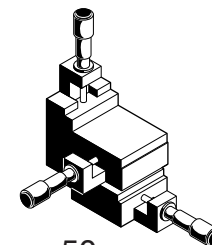

pg 50

Selection Guide

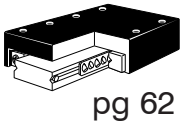

pg 62

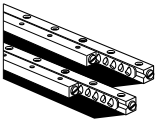

pg 65

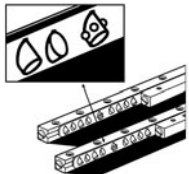

pg 69

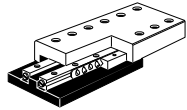

pg 72

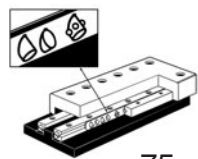

pg 75

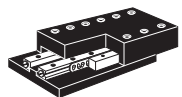

pg 78

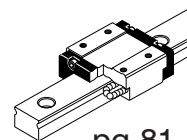

pg 81

LOW PROFILE CROSSED ROLLER TABLES

SERIES	LOAD CAPACITY, kg.	TRAVEL mm	LENGTH mm	ACCURACY
LPTA-1025-3205 (21 MODELS) Stainless steel available.	23 - 375	.2 - 130	25 - 205	.003mm/25mm

CROSSED ROLLER RAIL SETS

SERIES	LOAD CAPACITY, kg.	TRAVEL mm	LENGTH mm	ACCURACY
MINI NB1	20 - 84	12 - 50	20 - 80	.002mm/25mm
NB2-NB6 (49 MODELS) Stainless steel available.	30 - 1280	18 - 295	30 - 400	.002mm/25mm to .005mm/25mm

ANTI-CREEP CROSSED ROLLER RAIL SETS

SERIES	LOAD CAPACITY, Kg.	TRAVEL	LENGTH	ACCURACY
NB2-AC / NB6-AC (32 MODELS)	30-1280	18-275	30-400	.002mm/25mm .005mm/25mm

CROSSED ROLLER SLIDE TABLES (ALUMINUM)

SERIES	LOAD CAPACITY, kg.	TRAVEL mm	LENGTH mm	ACCURACY
MINI NBT-1AM	44 - 90	25 - 76	50 - 125	.003mm/25mm
NBT-2AM-NBT-6AM (72 MODELS) Stainless steel available.	30 - 923	18 - 229	35 - 360	.003mm/25mm

ANTI-CREEP CROSSED ROLLER SLIDE TABLES (ALUMINUM)

SERIES	LOAD CAPACITY, LB.	TRAVEL	LENGTH	ACCURACY
MINI NBTA1-AC	43-89	25-70	50-125	.003mm/25mm
NBT2A-AC / NBT6A-AC (31 MODELS)	30-924	18-230	35-360	.003mm/25mm

CROSSED ROLLER SLIDE TABLES (STEEL)

SERIES	LOAD CAPACITY, kg.	TRAVEL mm	LENGTH mm	ACCURACY
MINI NBT-1	12 - 40	12 - 50	25 - 85	.002mm
NBT-2-NBT-6 (41 MODELS)	40 - 1199	18 - 230	35 - 325	.002mm to .004mm

BALL SLIDE GUIDES

SERIES	LOAD CAPACITY, kg.	TRAVEL mm	LENGTH mm	ACCURACY
BSGS5-BSGS25	44 - 1001	3 - 813	38 - 889	.002mm
BSGS9W-BSGS16W (10 MODELS) Stainless steel.	250 - 720	51 - 610	76 - 660	.013mm

Ball Slides

6 Reasons to choose Del-Tron® Ball Slides

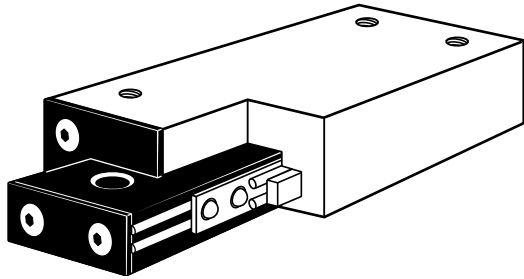

1. **Factory preload adjustment prevents sideplay and backlash.**
2. **Lightweight aluminum carriage and base with high load capacity.**
3. **Built-in holes simplify installation and component mounting.**
4. **Steel shafts, ground over the entire length, reduce coefficient of friction to 0.003.**
5. **Long life, self cleaning ball bearing needs no lubrication.**
6. **Mounting surfaces, parallel to the line of motion, provide straight line accuracy to .013mm/25mm of travel.**

Del-Tron® Ball Slides

Load Ratings and Life Estimates

The rated load capacity of Del-Tron® ball slides may be a mass load on a horizontal slide, or a force load normal to the mounting surface in any position. The rated load must be centered and distributed over the slide, and the base must be fully supported on a flat mounting surface so that the ball slide does not act as a beam subject to concentrated or distributed bending forces. Loads supported by protruding arms reduce accuracy and load capacity by acting as levers or ratio arms, and should be avoided even when load forces are small.

When used at the rated load capacity and moderate speeds, a life of 25 million cm of travel can be expected. The expected life at one half the rated load is 250 million cm.

Friction and Lubrication

The coefficient of friction is lower for linear ball bearings than for rotary bearings, where the peripheral track is shorter on the inner race than on the outer race, causing the ball to skid on one or the other. The balls run exactly equal distances on the pair of tracks in linear bearings, permitting the ball to run without friction, wear, or skidding at any preload. The typical coefficient of friction for Del-Tron® ball slides is 0.003.

Del-Tron® ball slides are self cleaning in normal service. Lubrication is recommended for speeds above 4500 cm/min, and is advisable at lower speeds where high loads are applied in continuous duty applications.

Mounting and Accuracy

The mounting surfaces of the ball slide are machined flat and smooth, and parallel to each other and the line of motion. They must be mounted on smooth, flat supports that will not deflect under load. Especially with long slides of small cross section, binding may be caused by distortion of the bottom member when mounted on irregular surfaces. If so, round shims or spacers may be placed over the mounting screws to raise the slide above the surface asperities. Bedding in epoxy resin is also recommended.

The specified accuracy for all standard Del-Tron® ball slides is .013mm/25mm of travel. This is measured by comparison of the line of travel to a master straight edge, using a gage or indicator mounted on the slide.

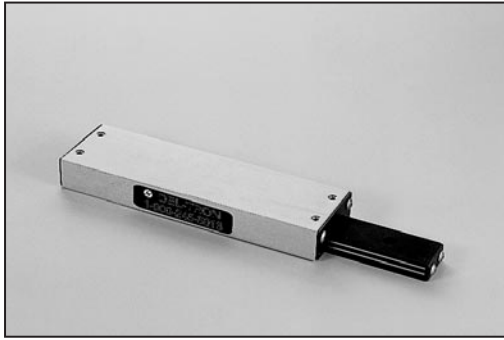

Ball Slide Assemblies

moment load ratings + load / life formulas. pg.91

* Minimum Centered around Mean Position

MODEL	TRAVEL*	LOAD CAPACITY (kg)	WEIGHT (g)	LENGTH A	HEIGHT B	WIDTH C	CARRIAGE HOLE SPACING		BASE DIMENSIONS		
							D	E	HEIGHT F	WIDTH G	HOLE SPACING H
CA-5	8.4	.34	2	13.3	5.8	9.7	6.0	4.0	3.4	4.0	6.0
CA-1	13	.68	3	19.0	5.8	9.7	13.0	4.0	3.4	4.0	10.0
CA-2	25	.68	4	32.0	5.8	9.7	26.0	4.0	3.4	4.0	20.0
CA-3	38	.68	7	44.0	5.8	9.7	37.0	4.0	3.4	4.0	30.0
DA-1	13	2	9	27.0	8.0	14.2	15.0	6.0	4.7	6.4	19.0
DA-2	25	4	14	52.0	8.0	14.2	41.0	6.0	4.7	6.4	35.0
DA-3	50	5	23	78.0	8.0	14.2	66.0	6.0	4.7	6.4	60.0
DA-4	75	6	31	103.0	8.0	14.2	92.0	6.0	4.7	6.4	86.0
DA-5	100	8	34	128.0	8.0	14.2	117.0	6.0	4.7	6.4	89.0
DA-6	127	8	43	154.0	8.0	14.2	142.0	6.0	4.7	6.4	114.0
EA-1	13	4	11	27.0	10.4	19.0	15.0	9.0	6.3	9.5	19.0
EA-2	25	5	26	52.0	10.4	19.0	41.0	9.0	6.3	9.5	35.0
EA-3	50	5	37	78.0	10.4	19.0	66.0	9.0	6.3	9.5	60.0
EA-4	75	6	48	103.0	10.4	19.0	92.0	9.0	6.3	9.5	86.0
EA-5	100	7	60	128.0	10.4	19.0	117.0	9.0	6.3	9.5	89.0
EA-6	127	8	71	154.0	10.4	19.0	142.0	9.0	6.3	9.5	114.0
MA-1	13	5	34	40.0	12.7	25.4	32.0	10.0	6.3	12.7	32.0
MA-2	25	5	48	65.0	12.7	25.4	57.0	10.0	6.3	12.7	57.0
MA-2.5	38	6	54	78.0	12.7	25.4	65.0	10.0	6.3	12.7	65.0
MA-3	50	7	62	90.0	12.7	25.4	82.0	10.0	6.3	12.7	82.0
MA-4	75	8	142	116.0	12.7	25.4	108.0	10.0	6.3	12.7	108.0

Dimensions in mm

SERIES	CA	DA	EA	MA	NA	SA1	SA2	SA3
CARRIAGE 4 HOLES (I)	M2 THREAD	M2 THREAD	M3 THREAD	M4 THREAD	M4 THREAD	M4 THREAD	M4 THREAD	M5 THREAD
BASE HOLE d	M2 THREAD	2.2	3.5	3.5	4.6	4.6	4.6	5.8
BASE HOLE D ₁	-	4.0	6.1	6.1	8.1	8.1	8.1	10
BASE HOLE h	-	2.2	3.4	3.4	4.4	4.4	4.4	5.3
COUNTER BORE SCREW SIZE	N/A	M2	M3	M3	M4	M4	M4	M5

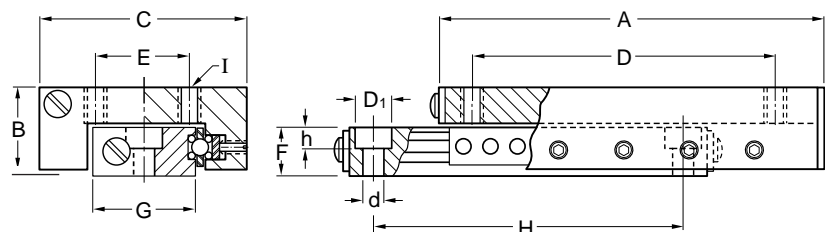

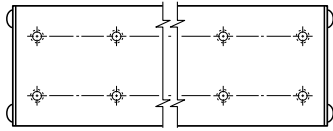

MODEL
SA3-6
SA3-9
SA3-12

OF HOLES
** 6
** 8
** 10

SPECIFICATIONS:

Straight Line Accuracy
.013mm/25mm of travel

Coefficient of Friction
0.003 typical

Positional Repeatability
.005mm

Construction
Aluminum carriage and base,
hardened steel shafts and balls,
mild steel end caps.

Finish
Clear anodize standard
Black anodize available at
no extra cost.

moment load ratings + load / life formulas. pg.91

*Minimum Centered around Mean Position											
MODEL	TRAVEL	LOAD CAPACITY (kg)	WEIGHT (g)	LENGTH A	HEIGHT B	WIDTH C	CARRIAGE HOLE SPACING		BASE DIMENSIONS		
							D	E	HEIGHT F	WIDTH G	HOLE SPACING H
NA-1	19	7	37	40.0	13.4	26.9	32.0	10.0	7.9	12.7	28.0
NA-2	38	8	65	65.0	13.4	26.9	57.0	10.0	7.9	12.7	54.0
NA-3	50	9	85	90.0	13.4	26.9	82.0	10.0	7.9	12.7	79.0
NA-4	75	11	147	116.0	13.4	26.9	102.0	10.0	7.9	12.7	82.0
NA-6	100	14	170	152.0	13.4	26.9	140.0	10.0	7.9	12.7	102.0
NA-8	150	16	198	203.0	13.4	26.9	190.0	10.0	7.9	12.7	127.0
NA-10	200	18	227	254.0	13.4	26.9	240.0	10.0	7.9	12.7	178.0
SA1-1	25	7	82	51.0	15.8	38.0	35.0	16.0	8.6	19.0	37.0
SA1-2	50	9	122	76.0	15.8	38.0	60.0	16.0	8.6	19.0	60.0
SA1-3	75	11	170	102.0	15.8	38.0	85.0	16.0	8.6	19.0	85.0
SA1-3.5	88	14	190	127.0	15.8	38.0	110.0	16.0	8.6	19.0	85.0
SA1-4	100	16	232	152.0	15.8	38.0	136.0	16.0	8.6	19.0	100.0
SA1-6	150	20	261	203.0	15.8	38.0	186.0	16.0	8.6	19.0	128.0
SA1-8	200	25	326	254.0	15.8	38.0	238.0	16.0	8.6	19.0	178.0
SA2-1	25	9	113	51.0	19.0	44.0	35.0	20.0	10.2	22.2	38.0
SA2-1.5	38	14	170	70.0	19.0	44.0	55.0	20.0	10.2	22.2	55.0
SA2-2	50	19	184	83.0	19.0	44.0	65.0	20.0	10.2	22.2	65.0
SA2-3	75	24	227	102.0	19.0	44.0	85.0	20.0	10.2	22.2	85.0
SA2-4	100	27	335	152.0	19.0	44.0	140.0	20.0	10.2	22.2	100.0
SA2-6	150	34	445	203.0	19.0	44.0	190.0	20.0	10.2	22.2	126.0
SA2-8	200	41	553	254.0	19.0	44.0	240.0	20.0	10.2	22.2	178.0
SA3-1	25	14	283	67.0	25.4	66.5	54.0	35.0	15.9	38.1	54.0
SA3-1.5	38	16	283	67.0	25.4	66.5	42.0	35.0	15.9	38.1	42.0
SA3-2	50	28	425	102.0	25.4	66.5	75.0	35.0	15.9	38.1	75.0
SA3-3	75	40	590	127.0	25.4	66.5	100.0	35.0	15.9	38.1	100.0
SA3-4	100	54	771	152.0	25.4	66.5	125.0	35.0	15.9	38.1	125.0
SA3-5	127	61	879	203.0	25.4	66.5	175.0	35.0	15.9	38.1	187.0
SA3-6	150	68	498	229.0	25.4	66.5	**75.0	35.0	15.9	38.1	178.0
SA3-9	228	84	1318	305.0	25.4	66.5	**75.0	35.0	15.9	38.1	254.0
SA3-12	304	93	1644	381.0	25.4	66.5	**75.0	35.0	15.9	38.1	330.0

Dimensions in mm

Anti-Creep Linear Slides

6 Reasons to choose Del-Tron® Anti-Creep™ Ball Slides

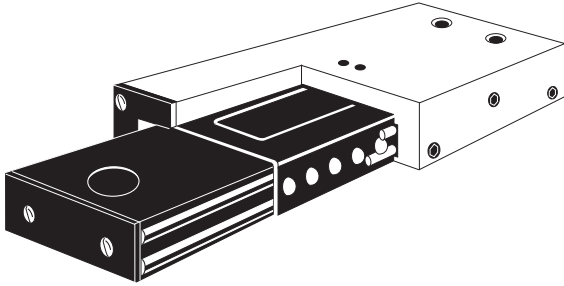

1. Ideal for vertical applications.
2. Increased life with overhanging loads.
3. Positive internal stops.
4. Low friction, straight line design.
5. Factory preload controls side play and backlash.
6. .013mm/25m" straight line accuracy.

Del-Tron® Anti-Creep™ Slides

In certain applications, uneven loads, improper preload, vertical mounting, or offset forces may cause the ball retainers to become misaligned relative to each other. The misalignment ("creep") can ultimately cause a reduction in overall travel, the need for increased force to achieve full travel and even failure of the assembly.

Del-Tron's® Anti-Creep™ retainer design prevents these problems. The single piece retainer and integral positive end stops prevent ball retainer misalignment and help keep the rolling elements centered in the assembly. The retainer is molded of engineering plastic and slotted in the center. Dowel pins mounted in the base and carriage limit the travel of the retainer and help to keep it centered in the slide for full travel and extended life. In applications in which retainer misalignment is a concern, Del-Tron® Anti-Creep™ slides demonstrate greatly increased life and improved performance. Anti-Creep™ slides have been extensively tested in Del-Tron's internal testing facility and successfully used in the field for over seven years. If you are concerned that your application may induce uneven loads or forces or if the need for a slide operating vertically exists, consider Del-Tron's® Anti-Creep™ retainer design.

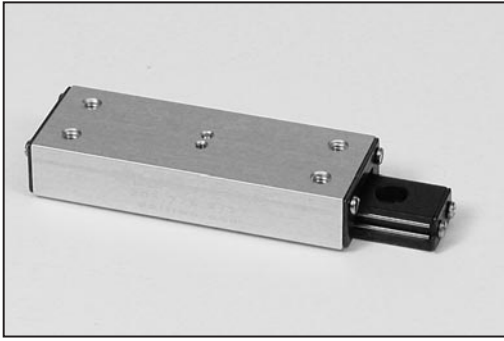

Anti-Creep Linear Slides

moment load ratings + load / life formulas. pg.91

* Minimum Centered around Mean Position											
MODEL	TRAVEL*	LOAD CAPACITY (kg)	WEIGHT (g)	LENGTH A	HEIGHT B	WIDTH C	CARRIAGE HOLE SPACING		BASE DIMENSIONS		
							D	E	HEIGHT F	WIDTH G	HOLE SPACING H
CA-1AC	13	.68	3	19.0	5.8	9.7	13.0	4.0	3.4	4.0	10.0
CA-2AC	25	.68	4	32.0	5.8	9.7	26.0	4.0	3.4	4.0	20.0
CA-3AC	38	.68	7	44.0	5.8	9.7	37.0	4.0	3.4	4.0	30.0
DA-1AC	13	2	9	27.0	8.0	14.2	15.0	6.0	4.7	6.4	19.0
DA-2AC	25	4	14	52.0	8.0	14.2	41.0	6.0	4.7	6.4	35.0
DA-3AC	50	5	23	78.0	8.0	14.2	66.0	6.0	4.7	6.4	60.0
DA-4AC	75	6	31	103.0	8.0	14.2	92.0	6.0	4.7	6.4	86.0
DA-5AC	100	8	34	128.0	8.0	14.2	117.0	6.0	4.7	6.4	89.0
DA-6AC	127	8	43	154.0	8.0	14.2	142.0	6.0	4.7	6.4	114.0
EA-1AC	13	4	11	27.0	10.4	19.0	15.0	9.0	6.3	9.5	19.0
EA-2AC	25	5	26	52.0	10.4	19.0	41.0	9.0	6.3	9.5	35.0
EA-3AC	50	5	37	78.0	10.4	19.0	66.0	9.0	6.3	9.5	60.0
EA-4AC	75	6	48	103.0	10.4	19.0	92.0	9.0	6.3	9.5	86.0
EA-5AC	100	7	60	128.0	10.4	19.0	117.0	9.0	6.3	9.5	89.0
EA-6AC	127	8	71	154.0	10.4	19.0	142.0	9.0	6.3	9.5	114.0
MA-1AC	13	5	34	40.0	12.7	25.4	32.0	10.0	6.3	12.7	32.0
MA-2AC	25	5	48	65.0	12.7	25.4	57.0	10.0	6.3	12.7	57.0
MA-2.5AC	38	6	54	78.0	12.7	25.4	65.0	10.0	6.3	12.7	65.0
MA-3AC	50	7	62	90.0	12.7	25.4	82.0	10.0	6.3	12.7	82.0
MA-4AC	75	8	142	116.0	12.7	25.4	108.0	10.0	6.3	12.7	108.0

Dimensions in mm

SERIES	CA	DA	EA	MA	NA	SA1	SA2	SA3
CARRIAGE 4 HOLES (t)	M2 THREAD	M2 THREAD	M3 THREAD	M4 THREAD	M4 THREAD	M4 THREAD	M4 THREAD	M5 THREAD
BASE HOLE d	M2 THREAD	2.2	3.5	3.5	4.6	4.6	4.6	5.8
BASE HOLE D ₁	-	4.0	6.1	6.1	8.1	8.1	8.1	10
BASE HOLE h	-	2.2	3.4	3.4	4.4	4.4	4.4	5.3
COUNTER BORE SCREW SIZE	N/A	M2	M3	M3	M4	M4	M4	M5

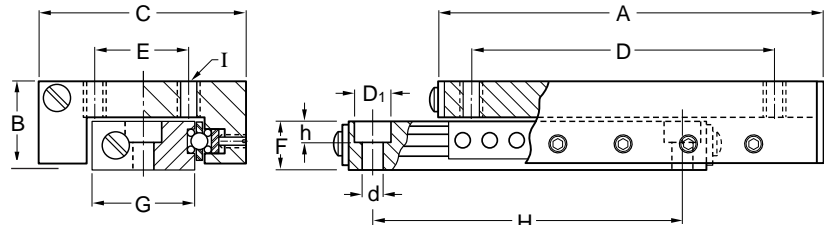

SPECIFICATIONS:

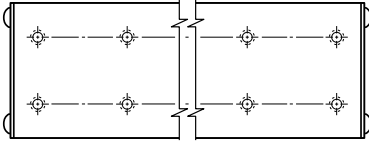

MODEL	# OF HOLES
SA3-6AC	** 6
SA3-9AC	** 8
SA3-12AC	** 10

Straight Line Accuracy
0.13mm/25mm of travel

Coefficient of Friction
0.003 typical

Positional Repeatability
.005mm

Construction
Aluminum carriage and base,
hardened steel shafts and balls,
mild steel end caps.

Finish
Clear anodize standard
black anodize available at
no extra cost.

moment load ratings + load / life formulas. pg.91

MODEL	TRAVEL*	LOAD CAPACITY (kg)	WEIGHT (g)	LENGTH A	HEIGHT B	WIDTH C	CARRIAGE HOLE SPACING		BASE DIMENSIONS		
							D	E	HEIGHT F	WIDTH G	HOLE SPACING H
NA-1AC	19	7	37	40.0	13.4	26.9	32.0	10.0	7.9	12.7	28.0
NA-2AC	38	8	65	65.0	13.4	26.9	57.0	10.0	7.9	12.7	54.0
NA-3AC	50	9	85	90.0	13.4	26.9	82.0	10.0	7.9	12.7	79.0
NA-4AC	75	11	147	116.0	13.4	26.9	102.0	10.0	7.9	12.7	82.0
NA-6AC	100	14	170	152.0	13.4	26.9	140.0	10.0	7.9	12.7	102.0
NA-8AC	150	16	198	203.0	13.4	26.9	190.0	10.0	7.9	12.7	127.0
NA-10AC	200	18	227	254.0	13.4	26.9	240.0	10.0	7.9	12.7	178.0
SA1-1AC	25	7	82	51.0	15.8	38.0	35.0	16.0	8.6	19.0	37.0
SA1-2AC	50	9	122	76.0	15.8	38.0	60.0	16.0	8.6	19.0	60.0
SA1-3AC	75	11	170	102.0	15.8	38.0	85.0	16.0	8.6	19.0	85.0
SA1-3.5AC	88	14	190	127.0	15.8	38.0	110.0	16.0	8.6	19.0	85.0
SA1-4AC	100	16	232	152.0	15.8	38.0	136.0	16.0	8.6	19.0	100.0
SA1-6AC	150	20	261	203.0	15.8	38.0	186.0	16.0	8.6	19.0	128.0
SA1-8AC	200	25	326	254.0	15.8	38.0	238.0	16.0	8.6	19.0	178.0
SA2-1AC	25	9	113	51.0	19.0	44.0	35.0	20.0	10.2	22.2	38.0
SA2-1.5AC	38	14	170	70.0	19.0	44.0	55.0	20.0	10.2	22.2	55.0
SA2-2AC	50	19	184	83.0	19.0	44.0	65.0	20.0	10.2	22.2	65.0
SA2-3AC	75	24	227	102.0	19.0	44.0	85.0	20.0	10.2	22.2	85.0
SA2-4AC	100	27	335	152.0	19.0	44.0	140.0	20.0	10.2	22.2	100.0
SA2-6AC	150	34	445	203.0	19.0	44.0	190.0	20.0	10.2	22.2	126.0
SA2-8AC	200	41	553	254.0	19.0	44.0	240.0	20.0	10.2	22.2	178.0
SA3-1AC	25	14	283	67.0	25.4	66.5	54.0	35.0	15.9	38.1	54.0
SA3-1.5AC	38	16	283	67.0	25.4	66.5	42.0	35.0	15.9	38.1	42.0
SA3-2AC	50	28	425	102.0	25.4	66.5	75.0	35.0	15.9	38.1	75.0
SA3-3AC	75	40	590	127.0	25.4	66.5	100.0	35.0	15.9	38.1	100.0
SA3-4AC	100	54	771	152.0	25.4	66.5	125.0	35.0	15.9	38.1	125.0
SA3-5AC	127	61	879	203.0	25.4	66.5	175.0	35.0	15.9	38.1	187.0
SA3-6AC	150	68	498	229.0	25.4	66.5	*75.0	35.0	15.9	38.1	178.0
SA3-9AC	228	84	1318	305.0	25.4	66.5	*75.0	35.0	15.9	38.1	254.0
SA3-12AC	304	93	1644	381.0	25.4	66.5	*75.0	35.0	15.9	38.1	330.0

Non-Magnetic Linear Slides

6 Reasons to choose Del-Tron® Non-Magnetic Ball Slides

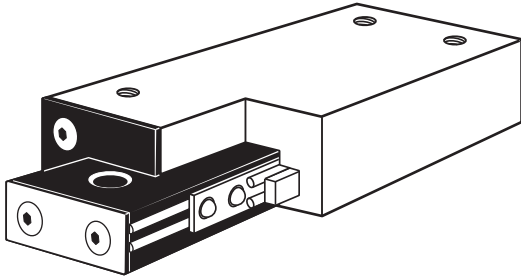

1. Non-Magnetic lightweight design.
2. Silicon nitride ceramic ball bearings, titanium shafts, aluminum carriage and base, brass fasteners.
3. Factory preload minimizes side play and provides low friction.
4. Self cleaning ball bearing design offers long life and requires no lubrication.
5. Standard mounting holes simplify installation.
6. Mounting surfaces, parallel to the line of motion, provide straight line accuracy to 0.013mm/25mm of travel.

Del-Tron® Ball Slides

Load Ratings and Life Estimates

The rated load capacity of Del-Tron ball slides may be a mass load on a horizontal slide, or a force load normal to the mounting surface in any position. The rated load must be centered and distributed over the slide, and the base must be fully supported on a flat mounting surface so that the ball slide does not act as a beam subject to concentrated or distributed bending forces. Loads supported by protruding arms reduce accuracy and load capacity by acting as levers or ratio arms, and should be avoided even when load forces are small.

When used at the rated load capacity and moderate speeds, a life of 10 million inches of travel can be expected. The expected life at one half the rated load is 100 million inches.

Friction and Lubrication

The coefficient of friction is lower for linear ball bearings than for rotary bearings, where the peripheral track is shorter on the inner race than on the outer race, causing the ball to skid on one or the other. The balls run exactly equal distances on the pair of tracks in linear bearings, permitting the ball to run without friction, wear, or skidding at any preload. The typical coefficient of friction for Del-Tron® ball slides is 0.003.

Lubrication is recommended for speeds above 1800 inches/min, and is advisable at lower speeds where high loads are applied in continuous duty applications.

Mounting and Accuracy

The mounting surfaces of the ball slide are machined flat and smooth, and parallel to each other and the line of motion. They must be mounted on smooth, flat supports that will not deflect under load. Especially with long slides of small cross section, binding may be caused by distortion of the bottom member when mounted on irregular surfaces. If so, round shims or spacers may be placed over the mounting screws to raise the slide above the surface asperities. Bedding in epoxy resin is also recommended.

The specified accuracy for all standard Del-Tron ball slides is .0005inch/inch of travel. This is measured by comparison of the line of travel to a master straight edge, using a gage or indicator mounted on the slide.

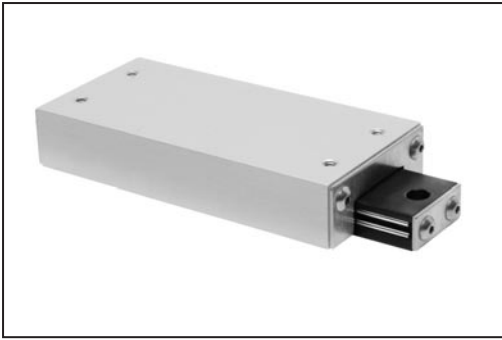

Non-Magnetic Linear Ball Slides

* Minimum Centered around Mean Position							CARRIAGE HOLE SPACING		BASE DIMENSIONS		
MODEL	TRAVEL*	LOAD CAPACITY (kg)	WEIGHT (g)	LENGTH A	HEIGHT B	WIDTH C	D	E	HEIGHT F	WIDTH G	HOLE SPACING H
DA-1-NMS	13	.5	9	27.0	8.0	14.2	15.0	6.0	4.7	6.4	19.0
DA-2-NMS	25	1.1	14	52.0	8.0	14.2	41.0	6.0	4.7	6.4	35.0
DA-3-NMS	50	1.6	23	78.0	8.0	14.2	66.0	6.0	4.7	6.4	60.0
DA-4-NMS	75	1.9	31	103.0	8.0	14.2	92.0	6.0	4.7	6.4	86.0
DA-5-NMS	100	2.2	34	128.0	8.0	14.2	117.0	6.0	4.7	6.4	89.0
DA-6-NMS	127	2.5	43	154.0	8.0	14.2	142.0	6.0	4.7	6.4	114.0
EA-1-NMS	13	1.1	11	27.0	10.4	19.0	15.0	9.0	6.3	9.5	19.0
EA-2-NMS	25	1.4	26	52.0	10.4	19.0	41.0	9.0	6.3	9.5	35.0
EA-3-NMS	50	1.6	37	78.0	10.4	19.0	66.0	9.0	6.3	9.5	60.0
EA-4-NMS	75	1.9	48	103.0	10.4	19.0	92.0	9.0	6.3	9.5	86.0
EA-5-NMS	100	2.2	60	128.0	10.4	19.0	117.0	9.0	6.3	9.5	89.0
EA-6-NMS	127	2.5	71	154.0	10.4	19.0	142.0	9.0	6.3	9.5	114.0
MA-1-NMS	13	1.4	34	40.0	12.7	25.4	32.0	10.0	6.3	12.7	32.0
MA-2-NMS	25	1.6	48	65.0	12.7	25.4	57.0	10.0	6.3	12.7	57.0
MA-2.5-NMS	38	1.8	54	78.0	12.7	25.4	65.0	10.0	6.3	12.7	65.0
MA-3-NMS	50	2.1	62	90.0	12.7	25.4	82.0	10.0	6.3	12.7	82.0
MA-4-NMS	75	2.5	142	116.0	12.7	25.4	108.0	10.0	6.3	12.7	108.0

Dimensions in mm

SERIES	DA	EA	MA	NA	SA1	SA2	SA3
CARRIAGE 4 HOLES (I)	M2 THREAD	M3 THREAD	M4 THREAD	M4 THREAD	M4 THREAD	M4 THREAD	M5 THREAD
BASE HOLE d	2.2	3.5	3.5	4.6	4.6	4.6	5.8
BASE HOLE D ₁	4.0	6.1	6.1	8.1	8.1	8.1	10
BASE HOLE h	2.2	3.4	3.4	4.4	4.4	4.4	5.3
COUNTER BORE SCREW SIZE	M2	M3	M3	M4	M4	M4	M5

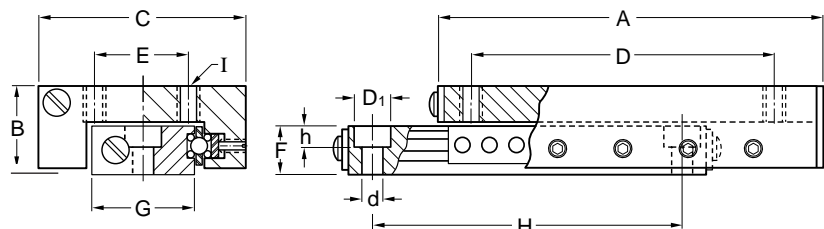

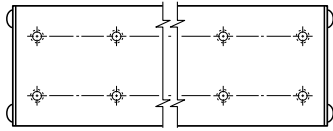

MODEL	# OF HOLES
SA3-6	** 6
SA3-9	** 8
SA3-12	** 10

SPECIFICATIONS:

Straight Line Accuracy
.013mm/25mm of travel

Coefficient of Friction
0.003 typical

Positional Repeatability
.005mm

Construction
Silicon nitride ceramic ball bearings, titanium shafts, aluminum carriage base and end caps, brass fasteners.

Finish
Clear anodize standard
Black anodize available at no extra cost.

*Minimum Centered around Mean Position											
MODEL	TRAVEL	LOAD CAPACITY (kg)	WEIGHT (g)	LENGTH A	HEIGHT B	WIDTH C	CARRIAGE HOLE SPACING		BASE DIMENSIONS		
							D	E	HEIGHT F	WIDTH G	HOLE SPACING H
NA-1-NMS	19	2.1	37	40.0	13.4	26.9	32.0	10.0	7.9	12.7	28.0
NA-2-NMS	38	2.5	65	65.0	13.4	26.9	57.0	10.0	7.9	12.7	54.0
NA-3-NMS	50	2.7	85	90.0	13.4	26.9	82.0	10.0	7.9	12.7	79.0
NA-4-NMS	75	3.4	147	116.0	13.4	26.9	102.0	10.0	7.9	12.7	82.0
NA-6-NMS	100	4.1	170	152.0	13.4	26.9	140.0	10.0	7.9	12.7	102.0
NA-8-NMS	150	4.8	198	203.0	13.4	26.9	190.0	10.0	7.9	12.7	127.0
NA-10-NMS	200	5.4	227	254.0	13.4	26.9	240.0	10.0	7.9	12.7	178.0
SA1-1-NMS	25	2.1	82	51.0	15.8	38.0	35.0	16.0	8.6	19.0	37.0
SA1-2-NMS	50	2.7	122	76.0	15.8	38.0	60.0	16.0	8.6	19.0	60.0
SA1-3-NMS	75	3.4	170	102.0	15.8	38.0	85.0	16.0	8.6	19.0	85.0
SA1-3.5-NMS	88	4.1	190	127.0	15.8	38.0	110.0	16.0	8.6	19.0	85.0
SA1-4-NMS	100	4.8	232	152.0	15.8	38.0	136.0	16.0	8.6	19.0	100.0
SA1-6-NMS	150	6.1	261	203.0	15.8	38.0	186.0	16.0	8.6	19.0	128.0
SA1-8-NMS	200	7.5	326	254.0	15.8	38.0	238.0	16.0	8.6	19.0	178.0
SA2-1-NMS	25	2.7	113	51.0	19.0	44.0	35.0	20.0	10.2	22.2	38.0
SA2-1.5-NMS	38	4.1	170	70.0	19.0	44.0	55.0	20.0	10.2	22.2	55.0
SA2-2-NMS	50	5.7	184	83.0	19.0	44.0	65.0	20.0	10.2	22.2	65.0
SA2-3-NMS	75	7.0	227	102.0	19.0	44.0	85.0	20.0	10.2	22.2	85.0
SA2-4-NMS	100	8.2	335	152.0	19.0	44.0	140.0	20.0	10.2	22.2	100.0
SA2-6-NMS	150	10.2	445	203.0	19.0	44.0	190.0	20.0	10.2	22.2	126.0
SA2-8-NMS	200	12.3	553	254.0	19.0	44.0	240.0	20.0	10.2	22.2	178.0
SA3-1-NMS	25	4.1	283	67.0	25.4	66.5	54.0	35.0	15.9	38.1	54.0
SA3-1.5-NMS	38	4.8	283	67.0	25.4	66.5	42.0	35.0	15.9	38.1	42.0
SA3-2-NMS	50	8.5	425	102.0	25.4	66.5	75.0	35.0	15.9	38.1	75.0
SA3-3-NMS	75	12.0	590	127.0	25.4	66.5	100.0	35.0	15.9	38.1	100.0
SA3-4-NMS	100	16.1	771	152.0	25.4	66.5	125.0	35.0	15.9	38.1	125.0
SA3-5-NMS	127	18.4	879	203.0	25.4	66.5	175.0	35.0	15.9	38.1	187.0
SA3-6-NMS	150	20.5	498	229.0	25.4	66.5	**75.0	35.0	15.9	38.1	178.0
SA3-9-NMS	228	25.2	1318	305.0	25.4	66.5	**75.0	35.0	15.9	38.1	254.0
SA3-12-NMS	304	28.0	1644	381.0	25.4	66.5	**75.0	35.0	15.9	38.1	330.0

Dimensions in mm

Crossed Roller Slides

6 Reasons to choose Del-Tron® Crossed Roller Slides

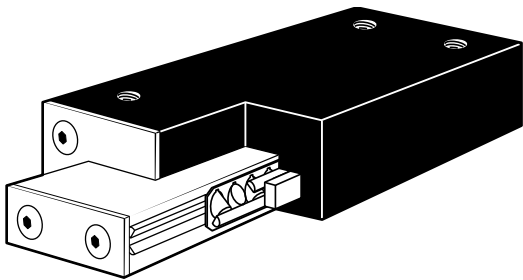

1. Positive stops prevent overtravel.
2. Rollers improve load capacity 8-10 times that of balls.
3. Precision ground shafts provide straight line accuracy of .003mm per 25mm of travel.
4. Alternately crossed rollers handle force in any direction.
5. Lightweight aluminum carriage and base.
6. Interchangeable with many types of ball slides.

Del-Tron® Crossed Roller Slides

Del-Tron's new series of crossed roller slides, offer designers additional flexibility in their choice of ready to install components for precision linear transfer.

Our crossed roller slides, when compared to our ball slide products of equal size, offer higher load carrying capacity and, when operating at high cycling rates or with shock and overhanging loads, improved performance. Most importantly, our crossed roller slides provide high accuracy, .003mm/25mm of travel, and repeatability, .003mm, exceeding our precision ball slides. Although crossed roller slides cost more than equivalent size ball slides, their overall performance, especially in applications where heavy loads must be moved in compact assemblies, often justifies selection.

Operation

Crossed roller slides physically resemble ball slides except for the bearing design. Specifically, each slide is comprised of an aluminum carriage straddling an aluminum base. Using a bearing system containing cylindrical steel rollers, the carriage glides, almost friction free, over the base.

The rollers, alternately crisscrossed with each other, move between a set of 4, partially flat, parallel, smooth rods on each side of the base. The rollers share a larger contact surface with the rods as compared to the point contact of steel balls. This bearing design allows crossed roller slides to carry larger loads and absorb greater load impacts than equivalent size ball slides.

Crossed roller slides are not as naturally self-cleaning in operation as ball slides. In operating environments, with little or no protection against dust and when heavy loads are not a consideration, consider Del-Tron® ball slides.

Wide Selection

Del-Tron offers over 47 models of crossed roller slides. Load capacities range from 14 kg to 354 kg, with travel from 13mm to 300mm. Installation into your system is simple. Counterbored holes in the base permit quick attachment to your assembly. Components attach to the carriage in the existing threaded mounting holes.

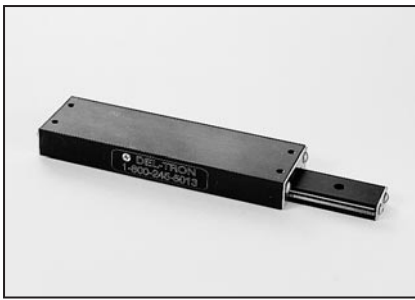

Crossed Roller Slide Assemblies

LOAD RATINGS AND LIFE ESTIMATES

Crossed roller slide rated load capacities may be a mass load on a horizontal slide, or a force load normal to the mounting surface in any position. The rated load must be centered and distributed over the slide, and the base must be supported on a flat mounting surface. Avoid concentrated or distributed bending forces.

At rated load capacity and moderate speeds, expected life is 25 million cm of travel. The expected life at one

half the rated load is 250 million cm.

LUBRICATION

The crossed roller slides are lightly lubricated during assembly. Additional lubrication is required for speeds above 30,000 mm/min. and is advisable at lower speeds where high loads are applied in continuous duty applications.

MOUNTING

Mount the crossed roller slides on flat surfaces to provide full support to the base.

moment load ratings + load / life formulas. pg.92

* Minimum Centered Around Mean Position											
MODEL	TRAVEL*	LOAD CAPACITY (kg)	WEIGHT (g)	LENGTH A	HEIGHT B	WIDTH C	CARRIAGE HOLE SPACING		BASE DIMENSIONS		
							D	E	HEIGHT F	WIDTH G	HOLE SPACING H
RDA-1	13	14	11	27.0	8.0	14.2	15.0	6.0	4.7	6.4	19.0
RDA-2	25	25	17	52.0	8.0	14.2	41.0	6.0	4.7	6.4	35.0
RDA-3	50	30	26	78.0	8.0	14.2	66.0	6.0	4.7	6.4	60.0
RDA-4	75	32	34	103.0	8.0	14.2	92.0	6.0	4.7	6.4	86.0
RDA-5	100	36	37	129.0	8.0	14.2	117.0	6.0	4.7	6.4	89.0
RDA-6	127	41	45	154.0	8.0	14.2	143.0	6.0	4.7	6.4	114.0
REA-1	13	22	14	27.0	10.4	19.0	15.0	9.0	6.3	9.5	19.0
REA-2	25	35	28	52.0	10.4	19.0	41.0	9.0	6.3	9.5	35.0
REA-3	50	42	40	78.0	10.4	19.0	66.0	9.0	6.3	9.5	60.0
REA-4	75	44	51	103.0	10.4	19.0	92.0	9.0	6.3	9.5	86.0
REA-5	100	47	62	129.0	10.4	19.0	117.0	9.0	6.3	9.5	89.0
REA-6	127	49	74	154.0	10.4	19.0	142.0	9.0	6.3	9.5	114.0
RMA-1	13	32	37	40.0	12.7	25.4	32.0	10.0	6.3	12.7	32.0
RMA-2	25	35	51	65.0	12.7	25.4	57.0	10.0	6.3	12.7	57.0
RMA-2.5	38	35	57	78.0	12.7	25.4	65.0	10.0	6.3	12.7	65.0
RMA-3	50	38	65	90.0	12.7	25.4	82.0	10.0	6.3	12.7	82.0
RMA-4	75	41	79	116.0	12.7	25.4	108.0	10.0	6.3	12.7	108.0

Dimensions in mm

SERIES	RDA	REA	RMA	RNA	RSA1	RSA2	RSA3
CARRIAGE 4 HOLES (I)	M2 THREAD	M3 THREAD	M4 THREAD	M4 THREAD	M4 THREAD	M4 THREAD	M5 THREAD
BASE HOLE d	2.2	3.5	3.5	4.6	4.6	4.6	5.8
BASE HOLE D1	4.0	6.1	6.1	8.1	8.1	8.1	10
BASE HOLE h	2.2	3.4	3.4	4.4	4.4	4.4	5.3
COUNTER BORE SCREW SIZE	M2	M3	M3	M4	M4	M4	M5

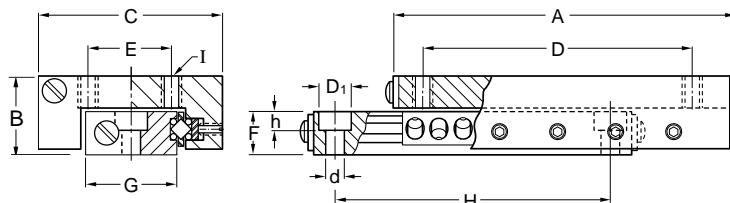

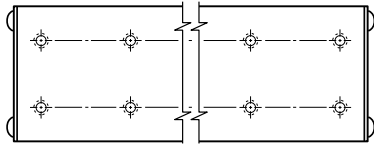

MODEL
 RSA3-6 **** 6**
 RSA3-9 **** 8**
 RSA3-12 **** 10**

SPECIFICATIONS:

Straight line accuracy .003mm/25mm of travel
Positional repeatability .003mm
Coefficient of friction .003 typical
Construction Aluminum carriage and base, hardened steel rods and rollers, stainless steel end caps.
Finish Black anodize

moment load ratings + load / life formulas. pg.92

* Minimum Centered Around Mean Position											
MODEL	TRAVEL *	LOAD CAPACITY (kg)	WEIGHT (g)	LENGTH A	HEIGHT B	WIDTH C	CARRIAGE HOLE SPACING		BASE DIMENSIONS		
							D	E	HEIGHT F	WIDTH G	HOLE SPACING H
RNA-1	19	50	40	40.0	13.4	26.9	32.0	10.0	7.9	12.7	28.0
RNA-2	38	60	68	65.0	13.4	26.9	57.0	10.0	7.9	12.7	54.0
RNA-3	50	100	88	90.0	13.4	26.9	82.0	10.0	7.9	12.7	79.0
RNA-4	75	120	150	116.0	13.4	26.9	102.0	10.0	7.9	12.7	82.0
RNA-6	100	129	173	152.0	13.4	26.9	140.0	10.0	7.9	12.7	102.0
RNA-8	150	135	204	203.0	13.4	26.9	190.0	10.0	7.9	12.7	127.0
RNA-10	200	145	232	254.0	13.4	26.9	240.0	10.0	7.9	12.7	178.0
RSA1-1	25	59	85	51.0	15.8	38.0	35.0	16.0	8.6	19.0	37.0
RSA1-2	50	79	128	76.0	15.8	38.0	60.0	16.0	8.6	19.0	60.0
RSA1-3	75	79	176	102.0	15.8	38.0	85.0	16.0	8.6	19.0	85.0
RSA1-3.5	89	95	196	127.0	15.8	38.0	111.0	16.0	8.6	19.0	85.0
RSA1-4	100	139	238	152.0	15.8	38.0	136.0	16.0	8.6	19.0	100.0
RSA1-6	150	163	266	203.0	15.8	38.0	186.0	16.0	8.6	19.0	127.0
RSA1-8	200	187	332	254.0	15.8	38.0	238.0	16.0	8.6	19.0	178.0
RSA2-1	25	59	116	51.0	19.0	44.0	35.0	20.0	10.2	22.2	38.0
RSA2-1.5	38	68	173	70.0	19.0	44.0	55.0	20.0	10.2	22.2	55.0
RSA2-2	50	79	187	83.0	19.0	44.0	65.0	20.0	10.2	22.2	65.0
RSA2-3	75	79	232	102.0	19.0	44.0	85.0	20.0	10.2	22.2	85.0
RSA2-4	100	139	343	152.0	19.0	44.0	140.0	20.0	10.2	22.2	100.0
RSA2-6	150	170	454	203.0	19.0	44.0	190.0	20.0	10.2	22.2	127.0
RSA2-8	200	204	561	254.0	19.0	44.0	240.0	20.0	10.2	22.2	178.0
RSA3-1	25	102	292	67.0	25.4	66.6	54.0	35.0	15.9	38.1	54.0
RSA3-1.5	38	119	292	67.0	25.4	66.6	42.0	35.0	15.9	38.1	42.0
RSA3-2	50	158	454	102.0	25.4	66.6	75.0	35.0	15.9	38.1	75.0
RSA3-3	75	198	635	127.0	25.4	66.6	100.0	35.0	15.9	38.1	100.0
RSA3-4	100	198	816	152.0	25.4	66.6	125.0	35.0	15.9	38.1	125.0
RSA3-5	127	215	936	203.0	25.4	66.6	175.0	35.0	15.9	38.1	187.0
RSA3-6	150	317	1089	229.0	25.4	66.6	**75.0	35.0	15.9	38.1	178.0
RSA3-9	228	336	1366	305.0	25.4	66.6	**75.0	35.0	15.9	38.1	254.0
RSA3-12	304	354	1729	381.0	25.4	66.6	**75.0	35.0	15.9	38.1	330.0

Dimensions in mm

Precision Series

6 Reasons to choose Del-Tron® Precision Series (Ball or Crossed Roller Slides)

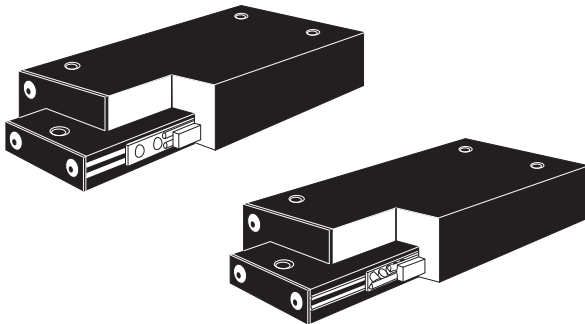

1. Corrosion resistant hardened stainless steel internal components.
2. Up to 127mm wide cross section.
3. Interchangeable with other manufacturer's products.
4. Low friction straight line design.
5. Adjustable preload.
6. Straight line design with 0.001mm repeatability

Precision Series (Ball or Crossed Roller Slides)

Del-Tron® Precision Series Ball and Roller Slides offer the designer an aluminum base and carriage with hardened stainless components for superior corrosion resistance and less chance of particulate contamination. Available in standard low profile mounting, the designer can choose a style of bearing and type of rolling element specifically to meet the needs of the most particular applications.

Preload can be adjusted to change the friction and axial play characteristics therefore customizing the slide to its intended use. A new 127mm wide cross section allows the movement of bulky devices without the necessity of constructing tables with more than one unit.

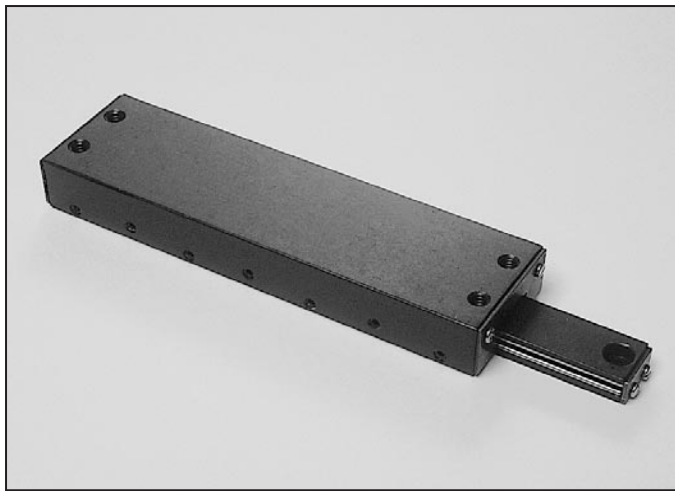

Precision Series Ball Slides

SPECIFICATIONS:

Straight Line Accuracy
.003mm/25mm of travel.

Repeatability
0.001mm

Coefficient of Friction
0.002

Construction

Aluminum carriage and base.
Hardened stainless steel balls,
shafts, pre-load gibs.
Interchangeable with other
manufacturers. Economical Ball
Slide design.

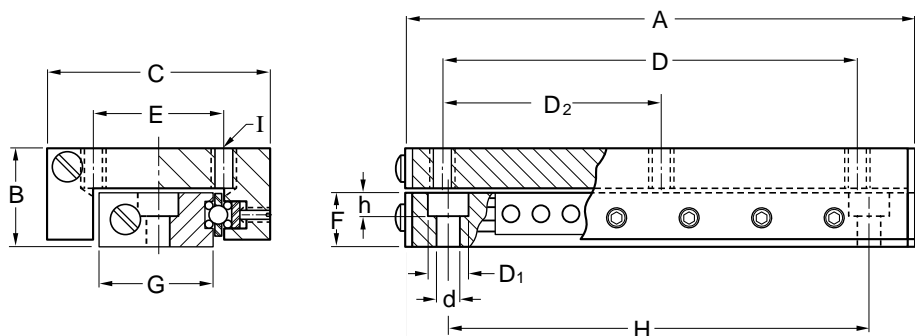

moment load ratings + load / life formulas. pg.92

*Minimum Centered Around Mean Position																
Model	Travel*	Load Capacity (kg)	Weight (g)	A	B	C	D	d	D ₁	D ₂	E	F	G	H	h	I
MA-2SS	25	5.4	57	65.0			57			-				57		
MA-3SS	50	9.1	79	90.4	12.7	25.4	83	3.5	6.1	-	10	6.4	10.2	83	3.4	M4
MA-4SS	75	10	102	115.8			108			-				108		
SA2-1SS	25	9.1	113	50.8			35			-				38		
SA2-1.5SS	38	15	154	69.9			54			-				54		
SA2-2SS	50	20	186	82.6	19.1	44.5	65	4.6	8.1	-	20	10.2	22.1	65	4.4	M4
SA2-3SS	75	25	227	101.6			85			-				85		
SA2-4SS	100	28	286	127.0			115			-				115		
SA3-1SS	25	16	295	66.5			54			-				54		
SA3-2SS	50	29	453	101.6			75			-				75		
SA3-3SS	75	42	567	127.0	25.4	66.5	100	5.8	10	-	35	15.5	38.1	100	5.3	M5
SA3-4SS	100	55	680	152.4			125			-				125		
SA3-5SS	125	63	794	203.2			175			-				187		
SA3-6SS	150	70	1021	228.6			150			75				178		
SA5-3SS	75	42	1021	127.0			100			50				100		
SA5-5SS	125	64	1474	177.8	25.4	127.0	150	7.1	11	75	100	15.5	98.3	150	6.2	M6
SA5-7SS	175	77	1928	228.6			200			100				200		

Dimensions in mm



Precision Series Crossed Roller Slides

SPECIFICATIONS:

Straight Line Accuracy
0.003mm/25mm of travel.

Repeatability
0.001mm

Coefficient of Friction
0.002.

Construction

Aluminum carriage and base.
Hardened stainless steel rollers,
shafts, pre-load gibs.
Interchangeable with other
manufacturers. Load capacities
up to 186 kg. Crossed Roller
design offers self-aligning ways
and greater load capacity.

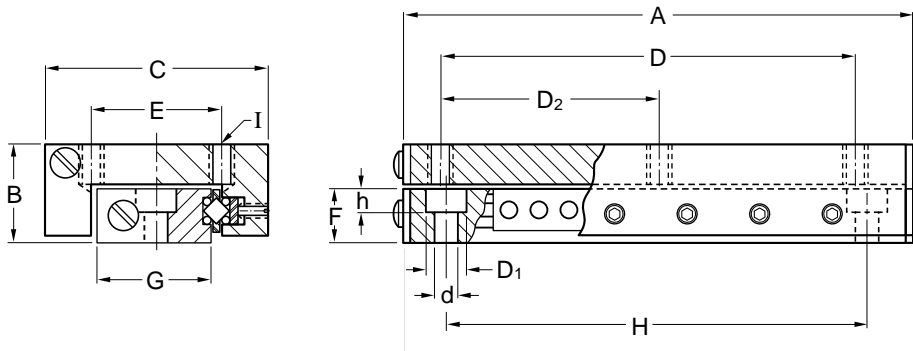

moment load ratings + load / life formulas. pg.92

*Minimum Centered Around Mean Position																
Model	Travel*	Load Capacity (kg)	Weight (g)	A	B	C	D	d	D ₁	D ₂	E	F	G	H	h	I
RSA2-1SS	25	36	127	50.8			35			-				38		
RSA2-2SS	50	54	209	82.6	19.0	44.5	65	4.6	8.1	-	20	10.2	22.1	65	4.6	M4
RSA2-3SS	75	59	254	101.6			85			-				85		
RSA2-4SS	100	64	286	127.0			115			-				115		
RSA3-1SS	25	95	299	66.5			54			-				54		
RSA3-2SS	50	109	454	101.6	25.4	67	75	5.8	10	-	35	15.5	38.1	75	5.3	M5
RSA3-3SS	75	154	567	127.0			100			-				100		
RSA3-4SS	100	173	680	152.4			125			-				125		
RSA3-5SS	125	186	907	203.2			175			-				187		
RSA5-3SS	75	100	1021	127.0			100			50				100		
RSA5-5SS	125	109	1474	177.8	25.4	127	150	7.1	11	75	100	15.5	98.3	150	6.2	M6
RSA5-7SS	175	118	1928	228.6			200			100				200		

Dimensions in mm

High Precision Series

6 Reasons to choose Del-Tron® High Precision Series (Ball or Crossed Roller Slides)

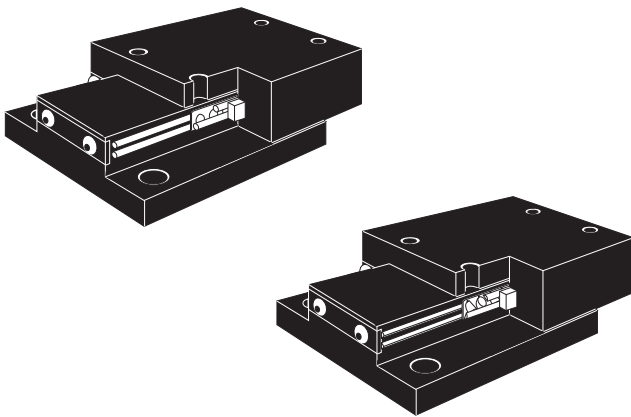

1. Stable flanged base style available
2. Superior accuracy and repeatability.
3. Precision ground carriage and base.
4. Corrosion resistant hardened stainless steel internal components.
5. Bigger cross sections and lengths for heavy loads and large moving parts.
6. Smooth low friction motion.

High Precision Series (Ball or Crossed Roller Slides)

Del-Tron® High Precision Series Ball and Crossed Roller Slides offer the designer highly accurate travel characteristics. .001mm/25mm of travel with superior repeatability of 0.0005mm. The base and carriage inner surfaces are ground to submicron tolerances while the mounting surfaces are flat to within .003mm/25mm.

The standard low profile style incorporates a base which is surrounded by the carriage leaving little surface to attract and hold contaminants. A flanged base style is offered to allow robust mounting at 4 points to assure stability in high impact or rough duty environments.

These slides utilize Del-Tron's straight line design which allows lower friction characteristics along with the option to manipulate the preload to adjust to the needs of the application.

New larger widths and lengths up to 146mm wide and 381mm long increase the versatility of this design.



High Precision Series Ball Slides (Low Profile)

SPECIFICATIONS:

Straight Line Accuracy
.001mm/25mm of travel.

Repeatability
0.0005mm

Coefficient of Friction
0.002

Construction

Aluminum carriage and base.
Hardened stainless steel balls,
shafts, pre-load gibs.
Interchangeable with other
manufacturers. Carriage and
base ground to optical flatness.
Bearing way surfaces held to
submicron tolerances.
Carriage surface flat to
.003mm/25mm. Ball Slide design
offers low rolling resistance and
economical price.

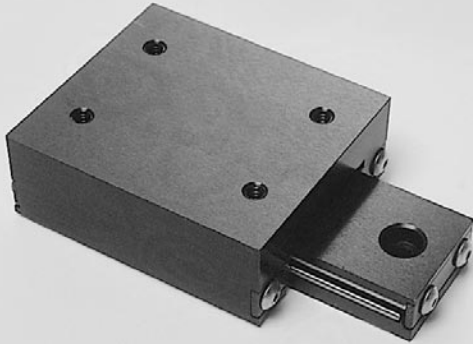

HPM SERIES ONLY

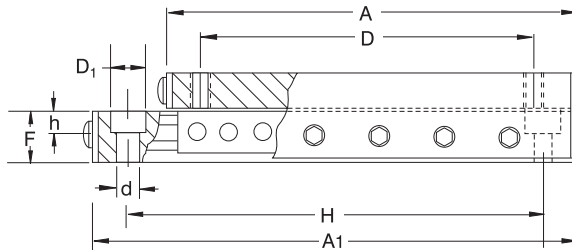
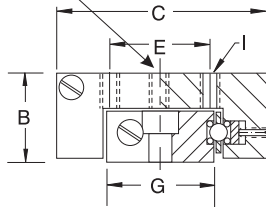

moment load ratings + load / life formulas. pg.93

*Minimum Centered Around Mean Position

Model	Travel*	Load Capacity (kg)	Weight (g)	A	A ₁	B	C	D	d	D ₁	E	F	G	H	h	I
HPMA-1	13	3.6	27	25.4	31.8			15						20		
HPMA-2	25	6.8	50	44.5	50.8	12.7	25.4	35	3.5	6.1	CL	6.1	10.2	40	3.4	M3
HPMA-2.5	38	11	73	63.5	69.9			54						57		
HPMA-3	50	14	91	82.6	88.8			70						75		
HPSA2-1	25	11	127	50.8	57.2			35						40		
HPSA2-1.5	38	14	172	69.9	76.2	19.0	44.5	54	4.6	8.1	20	10.2	22.1	57	4.6	M4
HPSA2-2	50	19	209	82.6	88.9			65						70		
HPSA2-3	75	23	254	101.6	108.0			85						90		
HPSA3-1	25	33	299	66.5	66.5			54						54		
HPSA3-2	50	38	454	101.6	111.0			75						85		
HPSA3-3	75	46	567	127.0	136.4	25.4	66.5	100	5.8	10	35	15.7	38.1	110	5.3	M5
HPSA3-4	100	60	680	152.4	161.8			125						135		
HPSA3-5	125	66	907	203.2	212.6			178						190		
HPSA4-2	50	59	907	101.6	114.3			50						65		
HPSA4-3	75	64	1306	146.1	158.8			95						110		
HPSA4-5	125	73	1814	203.2	215.9	34.9	88.9	150	5.8	10	50	15.7	50.3	175	5.3	M5
HPSA4-6.5	165	79	2327	260.4	273.1			210						225		
HPSA4-9	225	91	3175	355.6	368.3			305						320		
HPSA5-5	125	68	4536	209.6	222.3			150						175		
HPSA5-7	175	82	6586	304.8	317.5	50.8	146.1	250	7.1	11	100	24.9	94.0	275	6.2	M6
HPSA5-10	250	102	8233	381.0	393.7			330						350		

Dimensions in mm



High Precision Series Ball Slides (Flange Base)

SPECIFICATIONS:

Straight Line Accuracy
.001mm/25mm of travel.

Repeatability
0.0005mm

Coefficient of Friction
0.002

Construction

Aluminum carriage and base.
Hardened stainless steel balls,
shafts, pre-load gibs.
Interchangeable with other
manufacturers. Carriage and
base ground to optical flatness.
Bearing way surfaces held to
submicron tolerances. Carriage
surface flat to .003mm/25mm.
Flange Base design allows ease
of mounting and stability.

HPM SERIES ONLY

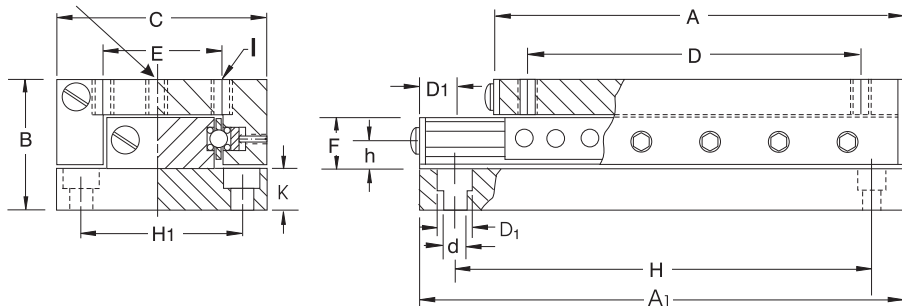

moment load ratings + load / life formulas. pg.93

*Minimum Centered Around Mean Position																	
Model	Travel*	Load Capacity (kg)	Weight (g)	A	A ₁	B	C	D	d	D ₁	E	F	H ₁	H	h	I	K
HPMA-1FB	13	3.6	36	25.4	31.8			15						20			
HPMA-2FB	25	6.8	64	44.5	50.8	19.1	25.4	35	3.5	6.1	CL	12.7	19	40	3.4	M3	6.4
HPMA-2.5FB	38	11	91	63.5	69.9			54						57			
HPMA-3FB	50	14	118	82.6	88.9			70						75			
HPSA2-1FB	25	11	172	50.8	57.2			35						40			
HPSA2-1.5FB	38	14	236	69.9	76.2	26.2	44.5	54	4.6	8.1	20	17.3	33	57	4.6	M4	7.1
HPSA2-2FB	50	19	277	82.6	88.9			65						70			
HPSA2-3FB	75	23	340	101.6	108.0			85						90			
HPSA3-1FB	25	33	413	66.5	66.5			54						54			
HPSA3-2FB	50	38	635	101.6	111.0			75						85			
HPSA3-3FB	75	46	794	127.0	136.4	34.9	66.5	100	5.8	10	35	25.4	52	110	5.3	M5	9.4
HPSA3-4FB	100	60	953	152.4	161.8			125						135			
HPSA3-5FB	125	66	1270	203.2	212.6			178						190			
HPSA4-2FB	50	59	1134	101.6	114.3			50						65			
HPSA4-3FB	75	64	1628	146.1	158.8			95						110			
HPSA4-5FB	125	73	2268	203.2	215.9	44.5	88.9	150	5.8	10	50	25.0	70	175	5.3	M5	9.4
HPSA4-6.5FB	165	79	2908	260.4	273.1			210						225			
HPSA4-9FB	225	91	3969	355.6	368.3			305						320			
HPSA5-5FB	125	68	5443	207.6	222.3			150						175			
HPSA5-7FB	175	82	7893	304.8	317.5	60.3	146.1	250	7.1	11	100	34.3	127	275	6.2	M6	9.4
HPSA5-10FB	250	102	9870	381.0	393.7			330						350			

Dimensions in mm



High Precision Series Crossed Roller Slides (Low Profile)

SPECIFICATIONS:

Straight Line Accuracy
.001 mm/25mm of travel.

Repeatability
0.0005mm

Coefficient of Friction
0.002

Construction

Aluminum carriage and base. Hardened stainless steel rollers, shafts, pre-load gibs. Interchangeable with other manufacturers. Carriage and base ground to optical flatness. Bearing way surfaces held to submicron tolerances. Carriage surface flat to .003mm/25mm. Crossed Roller design greatly increases load capacity and overhung load capability.

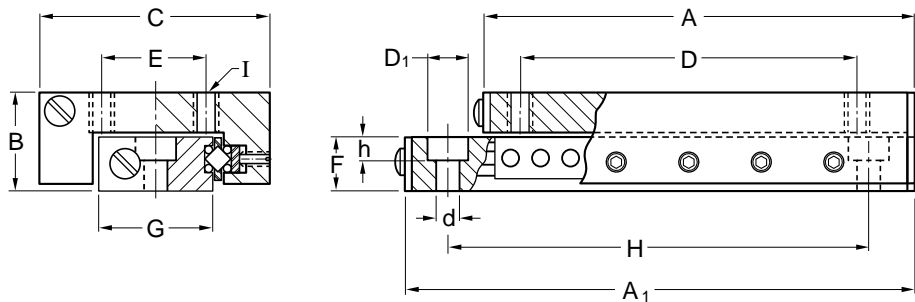

moment load ratings + load / life formulas. pg.93

*Minimum Centered Around Mean Position																
Model	Travel*	Load Capacity (kg)	Weight (g)	A	A ₁	B	C	D	d	D ₁	E	F	G	H	h	I
HPRSA2-1	25	41	127	50.8	57.2			35						40		
HPRSA2-1.5	38	68	172	69.9	76.2	19.1	44.5	54	4.6	8.1	20	10.2	22.1	57	4.6	M4
HPRSA2-2	50	59	209	82.6	88.9			65						70		
HPRSA2-3	75	64	254	101.6	108.0			85						90		
HPRSA3-1	25	100	299	66.5	66.5			54						54		
HPRSA3-2	50	114	454	101.6	111.0	25.4	66.5	75	5.8	10	35	15.7	38.1	85	5.3	M5
HPRSA3-3	75	159	567	127.0	136.4			100						110		
HPRSA3-4	100	177	680	152.4	161.8			125						135		
HPRSA3-5	125	191	907	203.2	212.6			178						190		
HPRSA4-2	50	118	907	101.6	114.3			50						65		
HPRSA4-3	75	127	1306	146.1	158.8	34.9	88.9	95	5.8	10	50	15.7	50.3	110	5.3	M5
HPRSA4-5	125	145	1814	203.2	215.9			150						175		
HPRSA4-6.5	165	159	2327	260.4	273.1			210						225		
HPRSA4-9	225	182	3175	355.6	368.3			305						320		
HPRSA5-5	125	136	4536	209.6	222.3			150						175		
HPRSA5-7	175	163	6586	304.8	317.5	50.8	146.1	250	7.1	11	100	24.9	94.0	275	6.2	M6
HPRSA5-10	250	204	8232	381.0	393.7			330						350		

Dimensions in mm

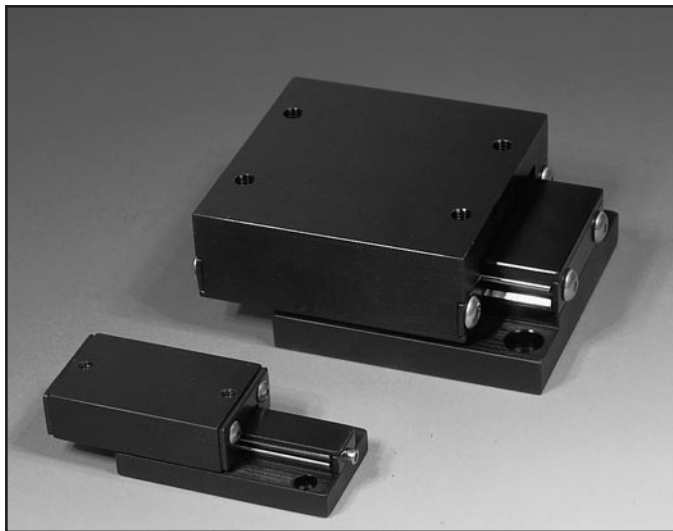

High Precision Series Crossed Roller Slides (Flange Base)

SPECIFICATIONS:

Straight Line Accuracy
.001mm/25mm of travel.

Repeatability
0.0005mm

Coefficient of Friction
0.002

Construction

Aluminum carriage and base.
Hardened stainless steel rollers,
shafts, pre-load gibs.
Interchangeable with other
manufacturers. Carriage and
base ground to optical flatness.
Bearing way surfaces held to
submicron tolerances. Carriage
surface flat to .003mm/25mm.
Flange Base with crossed roller
design offers the ultimate in
accuracy, capacity and stability.

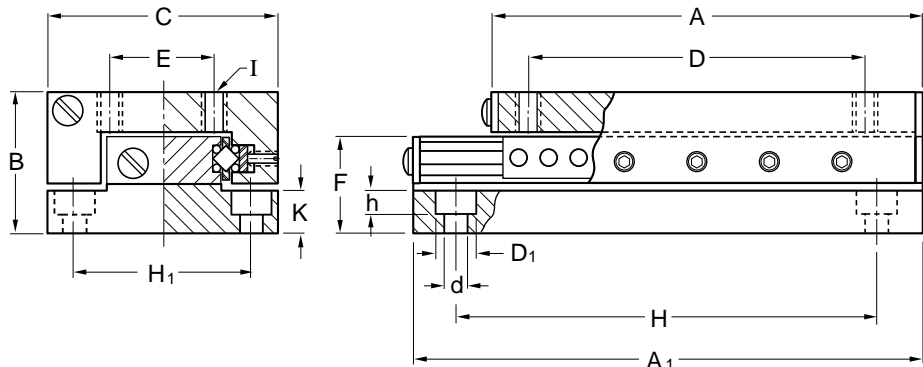

moment load ratings + load / life formulas. pg.93

*Minimum Centered Around Mean Position																	
Model	Travel*	Load Capacity (kg)	Weight (g)	A	A ₁	B	C	D	d	D ₁	E	F	H ₁	H	h	I	K
HPRSA2-1FB	25	41	172	50.8	57.2			35						40			
HPRSA2-1.5FB	38	52	236	69.9	76.2	26.2	44.5	54	4.6	8.1	20	17.3	33	57	4.6	M4	7.1
HPRSA2-2FB	50	59	277	82.6	88.9			65						70			
HPRSA2-3FB	75	64	340	101.6	108.0			85						90			
HPRSA3-1FB	25	100	413	66.9	66.5			54						54			
HPRSA3-2FB	50	114	635	101.6	111.0	34.9	66.5	75	5.8	10	35	25.4	52	85	5.3	M5	9.4
HPRSA3-3FB	75	159	794	127.0	136.4			100						110			
HPRSA3-4FB	100	177	953	152.4	161.8			125						135			
HPRSA3-5FB	125	191	1270	203.2	212.6			178						190			
HPRSA4-2FB	50	118	1134	101.6	114.3			50						65			
HPRSA4-3FB	75	127	1628	146.1	158.8	44.5	88.9	95	5.8	10	50	25.0	70	110	5.3	M5	9.4
HPRSA4-5FB	125	145	2268	203.2	215.9			150						175			
HPRSA4-6.5FB	165	159	2908	260.4	273.1			210						225			
HPRSA4-9FB	225	182	3969	355.6	368.3			305						320			
HPRSA5-5FB	125	136	5443	209.6	222.3			150						175			
HPRSA5-7FB	175	163	7893	304.8	317.5	60.3	146.1	250	7.1	11	100	34.3	127	275	6.2	M6	9.4
HPRSA5-10FB	250	204	9870	381.0	393.7			330						350			

Dimensions in mm

Mini Posi-Drive™ Stages

6 Reasons to choose Del-Tron® Mini Posi-Drive™ Stages (LSA1, LRSA1 Series)

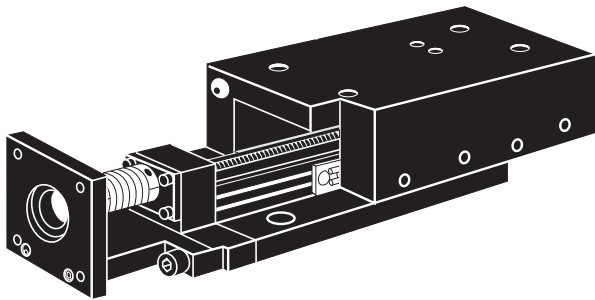

1. Positive lead screw drive.
2. Zero backlash.
3. Friction-free linear ball or roller slides.
4. Accurate, repeatable linear travel.
5. Compact adaptable configuration.
6. Adaptable to standard Nema Configurations.

Del-Tron® Mini Posi-Drive™ Stages

Compact Posi-Drive™ series LSA1 and LRSA1 stages have a height of only 32mm and a width of only 35mm. These stages provide the same outstanding .003mm straight line accuracy per 25mm of travel and .003mm repeatability as the larger LSA3 series Posi-Drive™ line. The new smaller stages also offer a compact, flexible configuration and are adaptable to standard Nema configurations.

The LSA1 Posi-Drive™ stages offer a .168" diameter .5mm lead screw, an anti-backlash nut and a flexible zero backlash coupling that accepts a Nema 14 motor. They provide a load-carrying capacity of up to 18.1 kg. The stages are available in travel lengths ranging from 25mm to 100mm. Del-Tron also provides special configurations, motor mounts, hand crank actuation and a variety of leads and pitches.

The new positioners are available with either linear ball or crossed roller slides and can be configured for one, two, or three-axis positioning. In the ball slide version, precision steel balls roll in the raceway grooves with contact at four points, enabling load and moment to be carried on all directions. Rolling resistance is extremely low, ensuring smooth and stable operation. Crossed roller slides physically resemble ball slides except for the bearing design. The rollers share a larger contact surface with the rods as compared to the point contact of steel balls. This bearing design allows crossed roller slides to carry larger loads and absorb greater load impacts than equivalent size ball slides.



Del-Tron® Mini Posi-Drive™ Stages

Specifications

Drive:	.168" diameter .5mm lead screw with anti-backlash nut.
Coupling:	Flexible zero backlash coupling.
Motor Mount:	Accepts Nema 14 motor
Travel:	25mm - 100mm
Anti-Friction Slide:	Linear ball or crossed roller slide.
Load Capacity:	Up to 18.1 kg
Configuration:	1, 2 or 3 axis.
Accuracy:	Straight line, up to .003mm/25mm of travel.
Repeatability:	.003mm

Also available are special configurations, motor mounts, hand crank actuation, and a variety of leads and pitches.

Motor/controller available.

Nomenclature

Part number for Mini Posi-Drive™ Stage

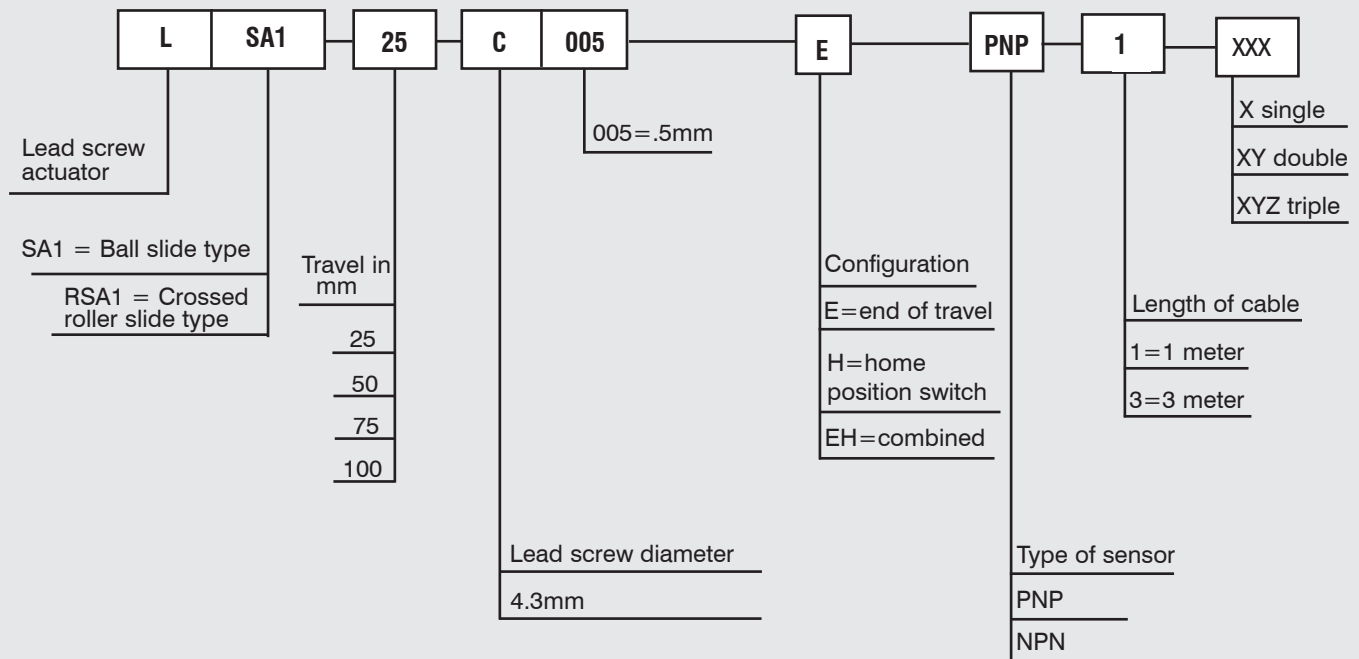

moment load ratings + load / life formulas. pg.93

Ball Slide Mini Posi-Drive™	Travel*	A	B	C	D	L	S	H	Load Capacity kg
LSA1-25-C005	25	103.4	50.8	52.6	35	.310	1.190	37	3.6
LSA1-50-C005	50	128.8	76.2	52.6	60	.810	.690	60	4.5
LSA1-75-C005	75	154.2	101.6	52.6	85	1.310	.990	85	6.8
LSA1-100-C005	100	211.3	152.4	58.9	135	2.310	.990	100	9.1

Dimensions in mm

moment load ratings + load / life formulas. pg.93

Roller Slide Mini Posi-Drive™	Travel*	A	B	C	D	H	L	S	Load Capacity kg
LRSA1-25-C005	25	103.4	50.8	52.6	35	37	.310	1.190	6.8
LRSA1-50-C005	50	128.8	76.2	52.6	60	60	.810	.690	9.1
LRSA1-75-C005	75	154.2	101.6	52.6	85	85	1.310	.990	13.6
LRSA1-100-C005	100	211.3	152.4	58.9	135	100	2.310	.990	18.1

Dimensions in mm

Mini Posi-Drive™ Series LSA1, LRSA1

Designed for NEMA 14 motor frame, other motor adaptors available. Supplied with coupling for 5mm motor shaft.
Couplings with inch and metric bore available. Standard travels of 25mm, 50mm, 75mm and 100mm

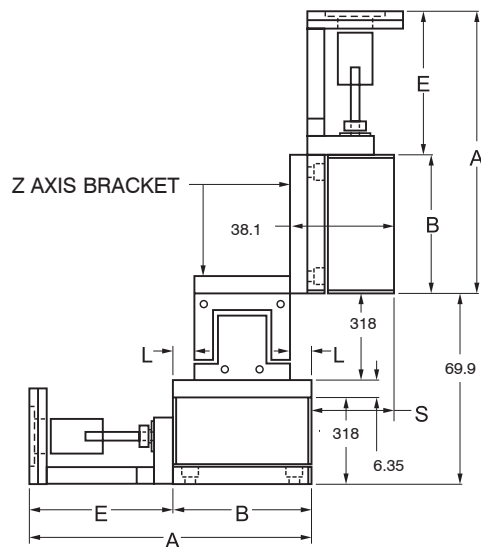
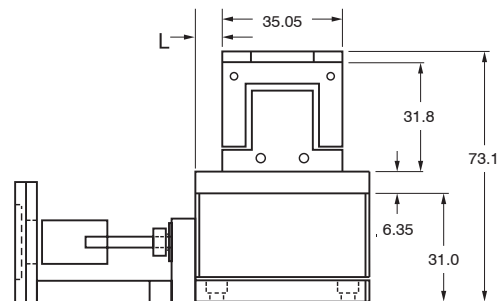
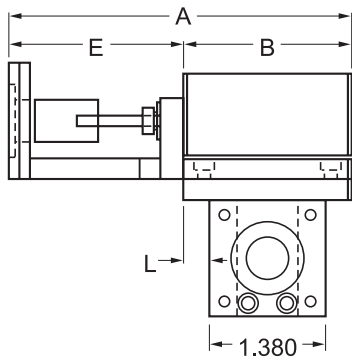
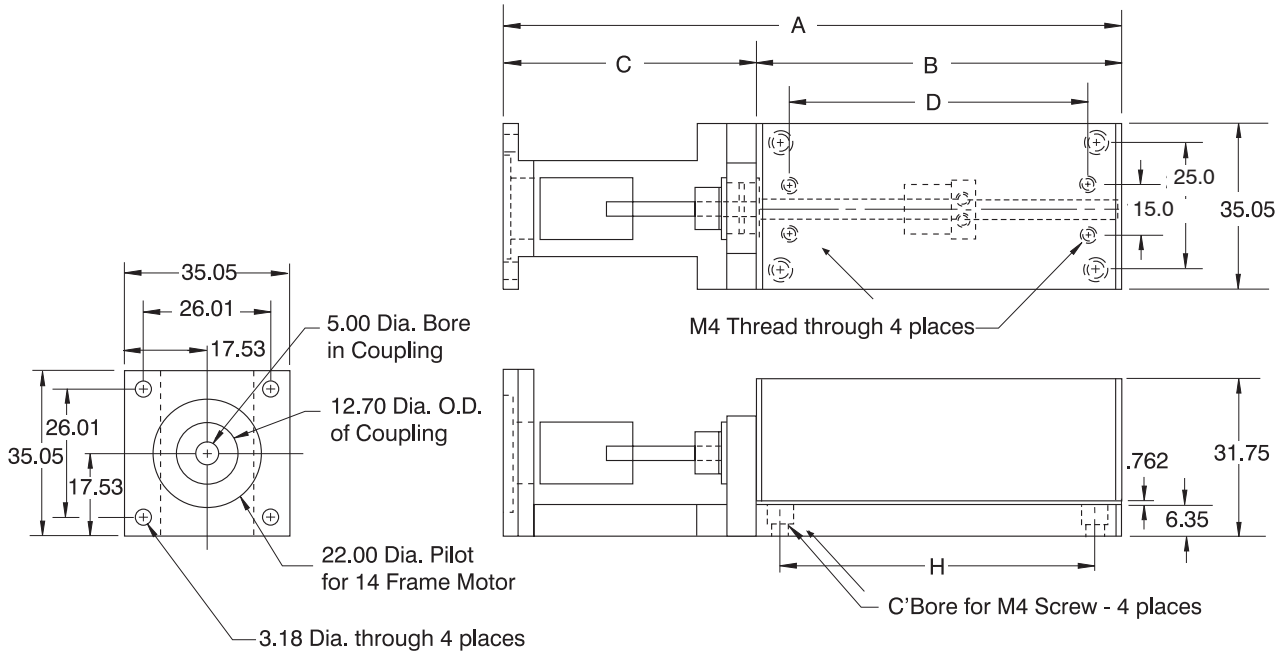

LIMIT AND POSITION SWITCHES

EOT (End Of Travel) and HPS (Home Position Switches)

Del-Tron Precision offers the addition of EOT and HPS to all 3 sizes of the Posi-Drive series. The EOT kit and the HPS kit could be used together or independently. The stand alone kits can be added to any of the 3 sizes of the Posi-Drive series. The EOT kit comes with 2 switches mounted to the base at each end. There are 2 flags that are mounted to the carriage. These flags are adjustable for either the full range of travel or for limited amount of travel if the application requires such. The Home Position Switch kit comes with 1 switch mounted to the base in the center. There is an adjustable flag mounted to the carriage. The adjustable flag will allow the Home Position to be set anywhere along the entire range of travel. The EOT and HPS are easily mounted to brackets, which are then attached to the base. The flags are easily assembled to a bracket that is then attached to the carriage. The base and carriage have the threaded mounting holes available for easy assembly of the brackets. The switches are photoelectric sensors that operate on a supply voltage of 5 to 24 VDC. The repeatability is .0002" and the response time is 100μseconds. The sensors are available in both NPN and PNP outputs. The sensors are equipped with a quick fitting Hook-Up Connector with cable lengths in 1m or 3m.

Part Numbering System for EOT and HPS

E-PNP-1
X-XXX-X

X-Configuration- E=EOT, H=HPS, EH=Combined
XXX=Type of Sensor, PNP or NPN
X=Length of Cable, 1=1meter, 3= 3 meter

Part Number

E-PNP-1
E-NPN-1
H-PNP-1
H-NPN-1
EH-PNP-1
EH-NPN-1

LSA1 and LRSA1 SERIES		
TRAVEL	B	J
25	50.8	38.1
50	76.2	63.5
75	101.6	88.9
110	152.4	139.7

Prices are the same for the 3 meter length cable and connector.

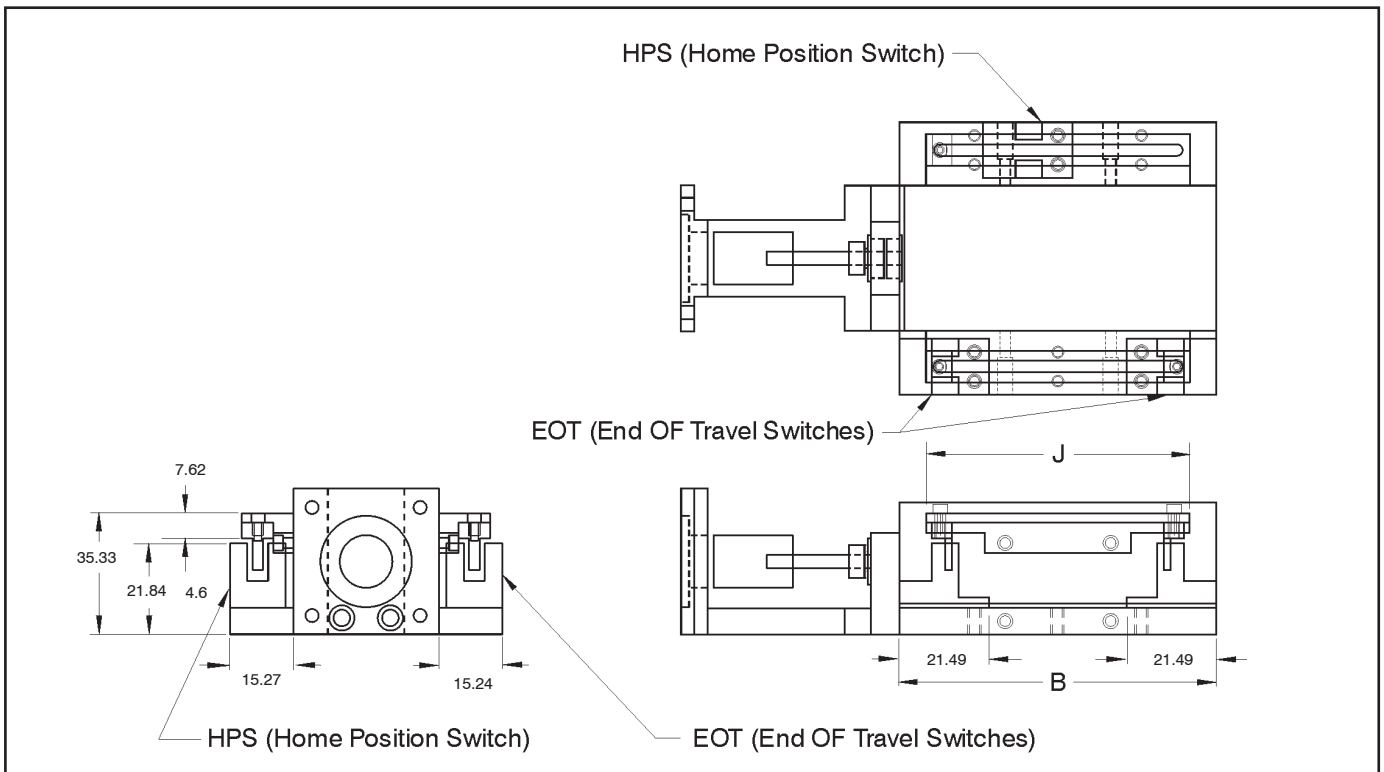

Maximum Recommended
Revolutions Per Second

Lead: .5mm	20 RPS
------------	--------

Mini Posi-Drive™ Stages

6 Reasons to choose Del-Tron® Mini Posi-Drive™ Stages (LSA2, LRSA2 Series)

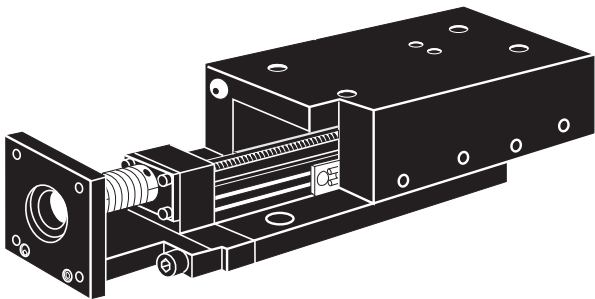

1. Positive lead screw drive.
2. Zero backlash.
3. Friction-free linear ball or roller slides.
4. Accurate, repeatable linear travel.
5. Compact adaptable configuration.
6. Adaptable to standard Nema Configurations.

Del-Tron® Mini Posi-Drive™ Stages

Compact Posi-Drive™ series LSA2 and LRSA2 stages have a height of only 41.9mm and a width of only 44.4mm. These stages provide the same outstanding .003mm straight line accuracy per 25mm of travel and .003mm repeatability as the larger LSA3 series Posi-Drive™ line. The new smaller stages also offer a compact, flexible configuration and are adaptable to standard Nema configurations.

The LSA2 Posi-Drive™ stages offer a .250" diameter 2mm lead screw, an anti-backlash nut and a flexible zero backlash coupling that accepts a Nema 17 motor. They provide a load-carrying capacity of up to 27.2 kg. The stages are available in travel lengths ranging from 25mm - 100mm. Del-Tron also provides special configurations, motor mounts, hand crank actuation and a variety of leads and pitches.

The new positioners are available with either linear ball or crossed roller slides and can be configured for one, two, or three-axis positioning. In the ball slide version, precision steel balls roll in the raceway grooves with contact at four points, enabling load and moment to be carried on all directions. Rolling resistance is extremely low, ensuring smooth and stable operation. Crossed roller slides physically resemble ball slides except for the bearing design. The rollers share a larger contact surface with the rods as compared to the point contact of steel balls. This bearing design allows crossed roller slides to carry larger loads and absorb greater load impacts than equivalent size ball slides.



Del-Tron® Mini Posi-Drive™ Stages

Specifications

Drive:	.250" diameter 2mm lead screw with anti-backlash nut.
Coupling:	Flexible zero backlash coupling.
Motor Mount:	Accepts Nema 17 motor
Travel:	25 - 100mm
Anti-Friction Slide:	Linear ball or crossed roller slide.
Load Capacity:	Up to 27.2 kg
Configuration:	1, 2 or 3 axis.
Accuracy:	Straight line, up to .003mm/25mm of travel.
Repeatability:	.003mm

Also available are special configurations, motor mounts, hand crank actuation, and a variety of leads and pitches.

Motor/controller available.

Nomenclature

Part number for Mini Posi-Drive™ Stage

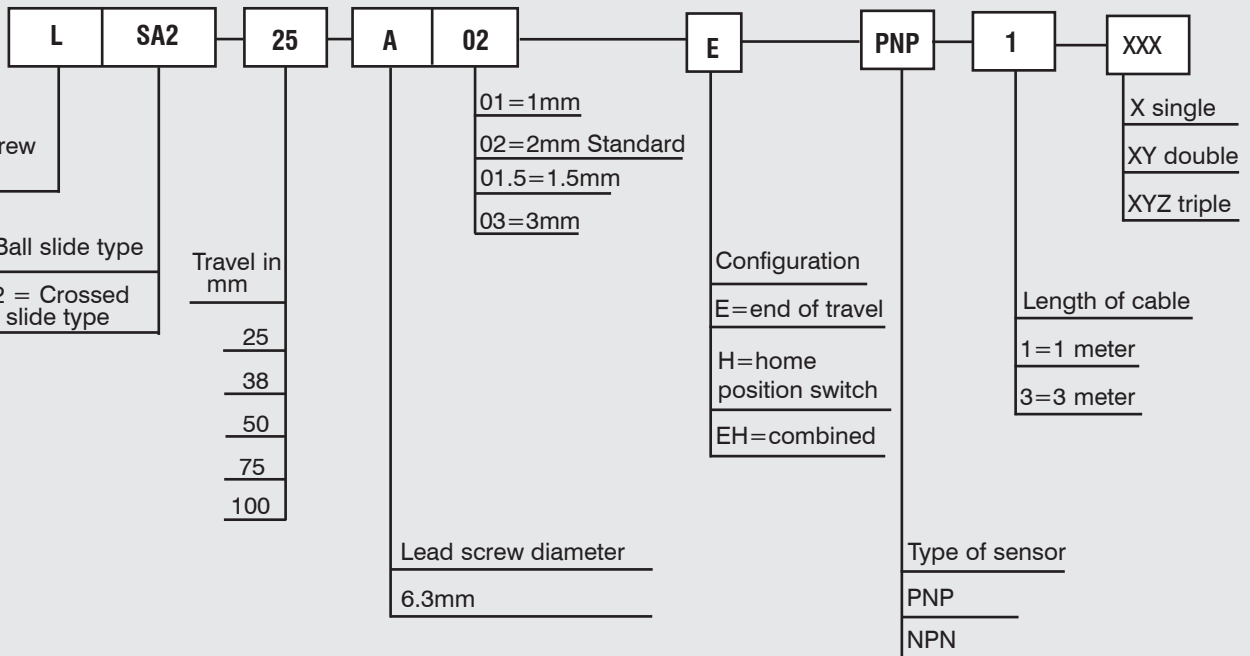

moment load ratings + load / life formulas. pg.93

Ball Slide Mini Posi-Drive	Travel	A	B	D	H	L	S	Load Capacity kg
LSA2-25-A02	25	124.0	57.2	35	38	.250	1.650	4.5
LSA2-38-A02	38	143.0	76.2	55	55	.625	1.275	6.8
LSA2-50-A02	50	155.7	88.9	65	65	.875	1.025	9.1
LSA2-75-A02	75	174.8	108.0	85	85	1.250	.650	11
LSA2-100-A02	100	219.2	152.4	140	100	2.125	1.775	14

Dimensions in mm

moment load ratings + load / life formulas. pg.93

Roller Slide Mini Posi-Drive	Travel	A	B	D	H	L	S	Load Capacity kg
LRSA2-25-A02	25	124.0	57.2	35	38	.250	1.650	9.1
LRSA2-38-A02	38	143.0	76.2	55	55	.625	1.275	14
LRSA2-50-A02	50	155.7	88.9	65	65	.875	1.025	18
LRSA2-75-A02	75	174.8	108.0	85	85	1.250	.650	23
LRSA2-100-A02	100	219.2	152.4	140	100	2.125	1.775	27

Dimensions in mm

Mini Posi-Drive Series LSA2, LRSA2

Designed for NEMA 17 motor frame, other motor adaptors available. Supplied with coupling for 5mm motor shaft.
 Couplings with inch and metric bore available. Uses a leadscrew with anti-backlash nut. Standard lead is 2mm. Leads available at no additional cost 1mm, 1.5mm, 2mm, 3mm and 4mm. Standard travels of 25, 38, 50, 75, and 100mm

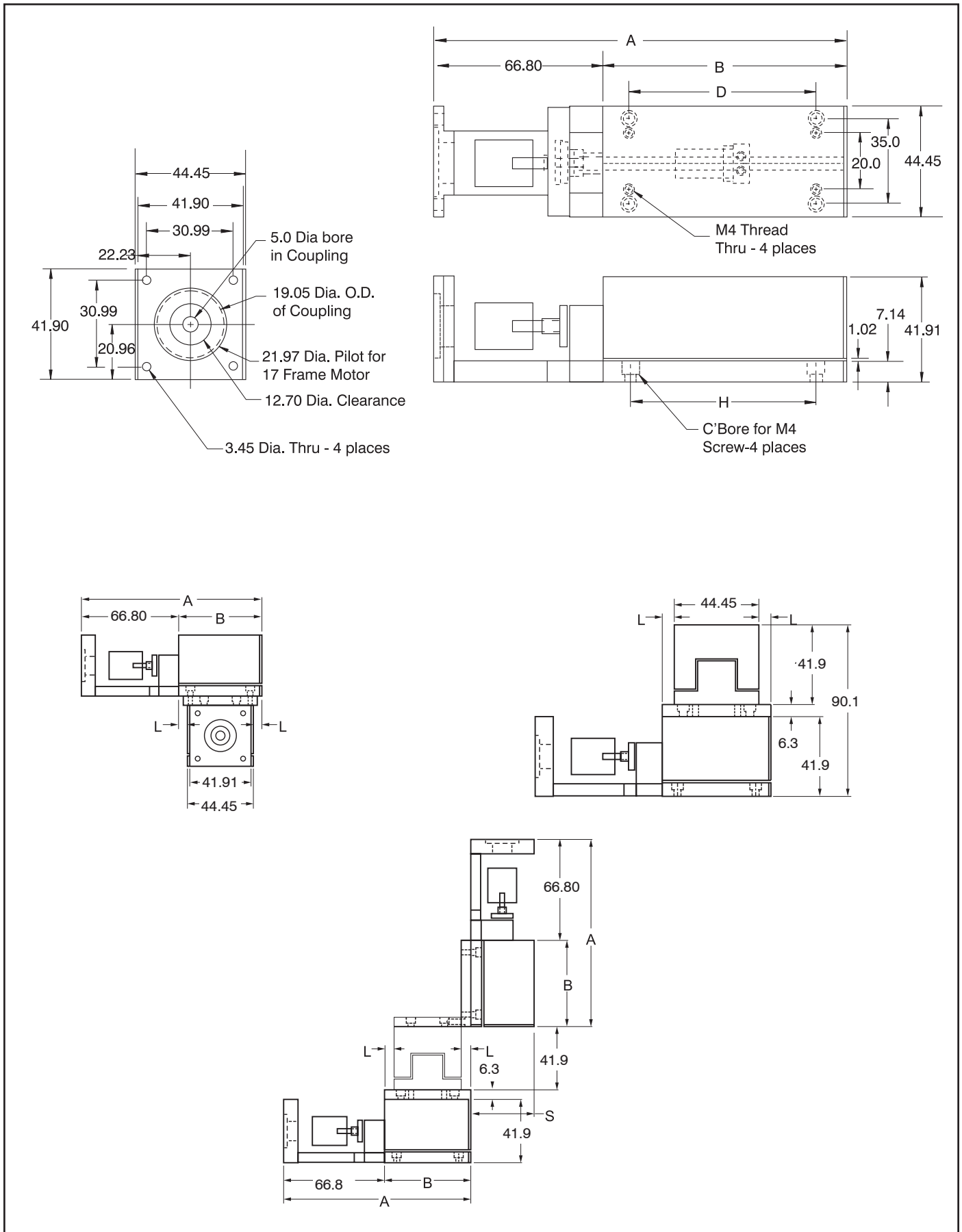

LIMIT AND POSITION SWITCHES

EOT (End Of Travel) and HPS (Home Position Switches)

Del-Tron Precision offers the addition of EOT and HPS to all 3 sizes of the Posi-Drive series. The EOT kit and the HPS kit could be used together or independently. The stand alone kits can be added to any of the 3 sizes of the Posi-Drive series. The EOT kit comes with 2 switches mounted to the base at each end. There are 2 flags that are mounted to the carriage. These flags are adjustable for either the full range of travel or for limited amount of travel if the application requires such. The Home Position Switch kit comes with 1 switch mounted to the base in the center. There is an adjustable flag mounted to the carriage. The adjustable flag will allow the Home Position to be set anywhere along the entire range of travel. The EOT and HPS are easily mounted to brackets, which are then attached to the base. The flags are easily assembled to a bracket that is then attached to the carriage. The base and carriage have the threaded mounting holes available for easy assembly of the brackets. The switches are photoelectric sensors that operate on a supply voltage of 5 to 24 VDC. The repeatability is .005mm and the response time is 100μseconds. The sensors are available in both NPN and PNP outputs. The sensors are equipped with a quick fitting Hook-Up Connector with cable lengths in 1m or 3m.

Part Numbering System for EOT and HPS

E-PNP-1
X-XXX-X

X-Configuration- E=EOT, H=HPS, EH=Combined
XXX=Type of Sensor, PNP or NPN
X=Length of Cable, 1=1meter, 3= 3 meter

Part Number

E-PNP-1
E-NPN-1
H-PNP-1
H-NPN-1
EH-PNP-1
EH-NPN-1

LSA2 and LRSA2 SERIES		
TRAVEL	B	T
25	57.15	41.27
38	76.20	60.32
50	88.90	73.02
75	107.95	92.07
100	152.40	136.52

Prices are the same for the 3 meter length cable and connector.

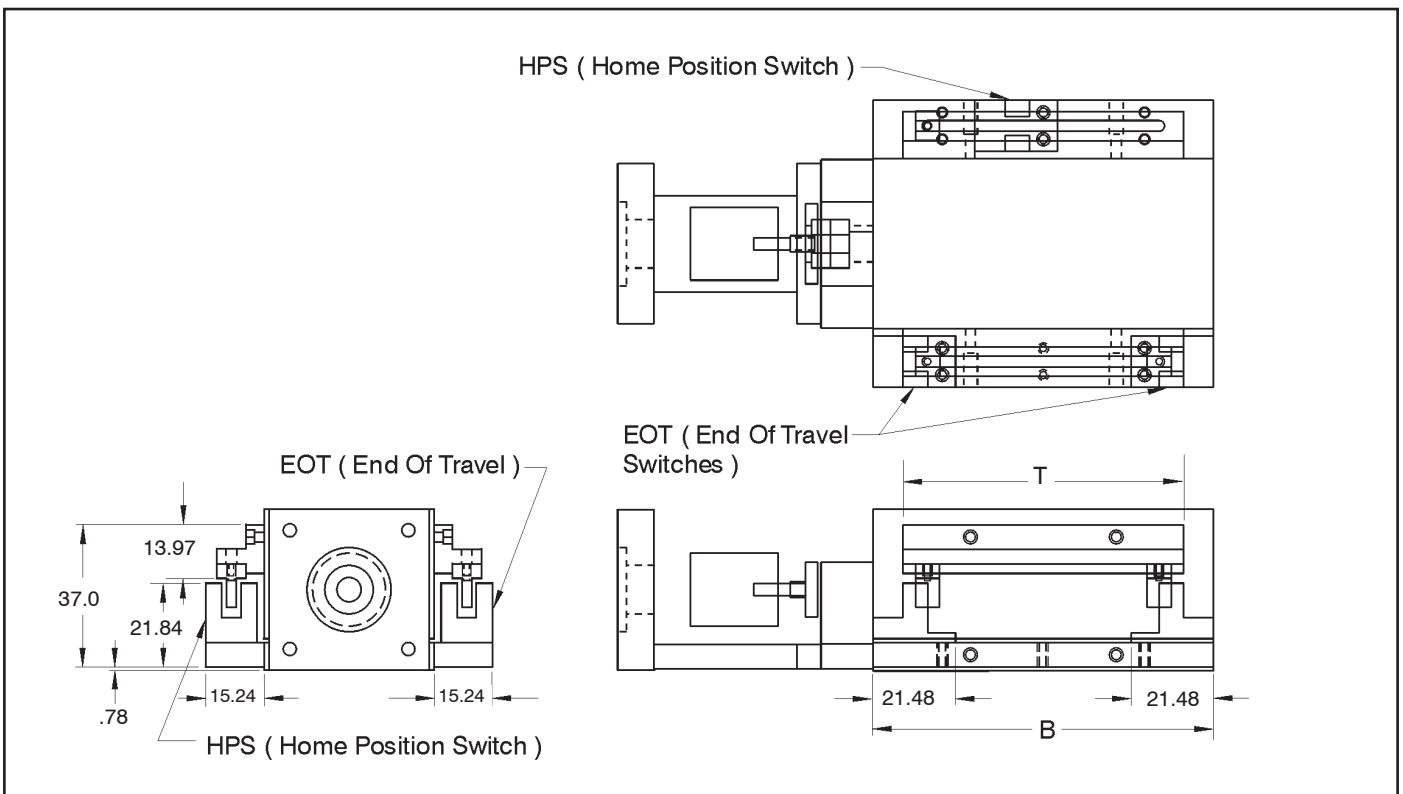

Maximum Recommended
Revolutions Per Second

Lead: .2mm	20 RPS
------------	--------

Posi-Drive™ Stages

6 Reasons to choose Del-Tron® Posi-Drive™ Stages

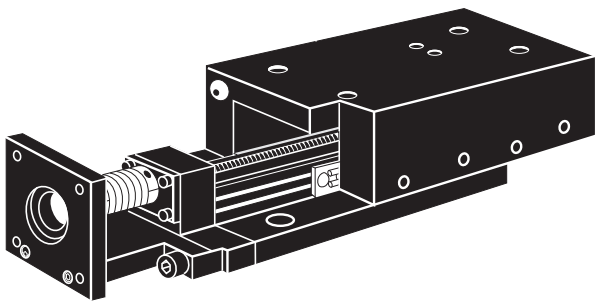

1. Positive lead screw drive.
2. Zero backlash.
3. Friction-free linear ball or roller slides.
4. Accurate, repeatable linear travel.
5. Compact adaptable configuration.
6. Adaptable to standard Nema Configurations.

Del-Tron® Posi-Drive™ Stages

Compact, economical Posi-Drive™ stages from Del-Tron take the work out of designing motion control systems. Our stages require no alignment of components, install with only four standard fasteners, are fitted with anti-backlash lead screws, multi-beam couplings with high speed misalignment capability and standard NEMA motor mounts.

Available in one, two or three axis configurations with either ball or crossed roller slides, these stages travel up to 300mm. The crossed roller slide option increases load capacity up to 82 kg and 2500 million mm of travel is possible at 1/2 rated load. Motor/controller packages can be provided.



Del-Tron® Posi-Drive™ Stages

Specifications

Drive:	10mm diameter 2mm lead screw with anti-backlash nut.
Leads Available:	3mm and 20mm
Coupling:	Flexible zero backlash coupling.
Motor Mount:	Accepts Nema 23 motor
Travel:	25 - 300mm
Anti-Friction Slide:	Linear ball or crossed roller slide.
Load Capacity:	Up to 82 kg
Configuration:	1, 2 or 3 axis.
Accuracy:	Straight line, up to .003mm/25mm of travel.
Repeatability:	.003mm

Also available are special configurations, motor mounts, hand crank actuation, and a variety of leads and pitches.

Motor/controller available.

Nomenclature

Part number for Posi-Drive™ Stage

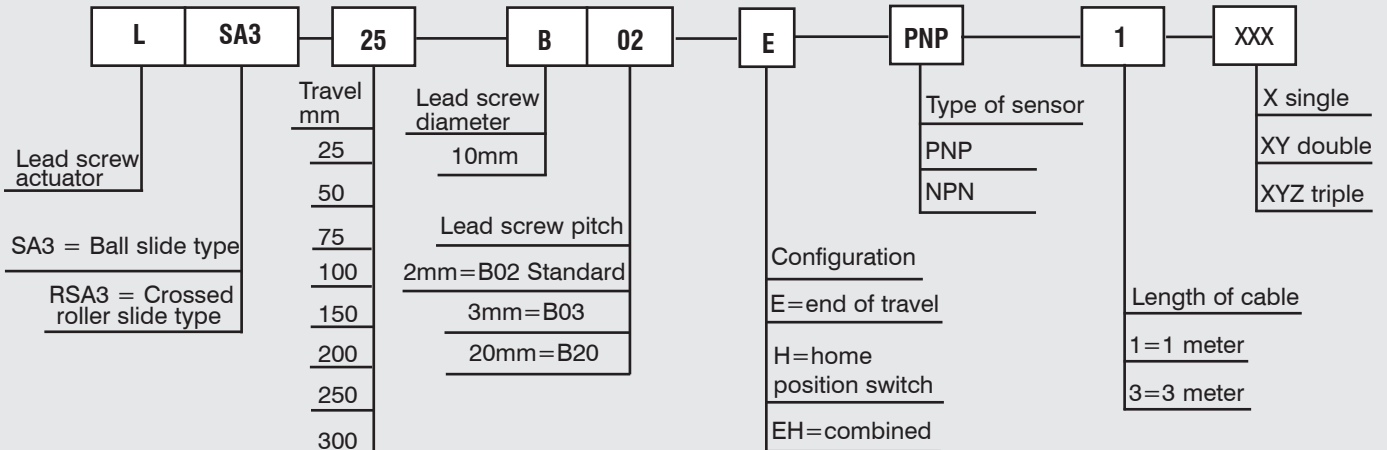

Designed for NEMA 23 motor frame. Supplied with coupling for 8mm motor shaft.
 Uses 10mm diameter lead-screw with anti-backlash nut. Standard lead is 2mm.
 Standard travels of 25-300mm
 Other motor adapters and coupling with inch and metric bore available as special order.
 Leads available in 3mm and 20mm

moment load ratings + load / life formulas. pg.93

Posi-Drive™																		
MODEL	A	A1	B	B1	D	P	E	F	G	H	H1	J	K	L	M	N	R	S
LSA3-25-B02	143		76		55		67	10.5	13.0	60	0	0	8.0	5	0	95	8	52
LSA3-50-B02	168		102		75		67	13.5	26.0	60	85	8.5	21.0	17	0	95	8	40
LSA3-75-B02	194		127		100		67	13.5	38.5	60	110	8.5	33.5	30	0	95	8	27
LSA3-100-B02	219		152		125		67	13.5	51.0	60	135	8.5	46.0	43	0	95	19	14
LSA3-150-B02	321	329	229	237		10	92	39.5	89.5	100	175	27.0	64.5	81	10	104	44	-24
LSA3-200-B02	397	405	279	287		12	118	27.0	114.5	150	225	27.0	64.5	106	10	104	70	-49
LSA3-250-B02	473	482	330	338		14	143	15.0	140.0	200	275	27.5	65.0	132	10	104	95	-75
LSA3-300-B02	549	558	381	389		14	168	40.5	165.5	250	325	28.0	65.5	157	10	104	121	-100
<hr/>																		
LRSA3-25-B02	143		76		55		67	10.5	13.0	60	0	0	8.0	5	0	95	8	52
LRSA3-50-B02	168		102		75		67	13.5	26.0	60	85	8.5	21.0	17	0	95	8	40
LRSA3-75-B02	194		127		100		67	13.5	38.5	60	110	8.5	33.5	30	0	95	8	27
LRSA3-100-B02	219		152		125		67	13.5	51.0	60	135	8.5	46.0	43	0	95	19	14
LRSA3-150-B02	321	329	229	237		10	92	39.5	89.5	100	175	27.0	64.5	81	10	104	44	-24
LRSA3-200-B02	397	405	279	287		12	118	27.0	114.5	150	225	27.0	64.5	106	10	104	70	-49
LRSA3-250-B02	473	482	330	338		14	143	15.0	140.0	200	275	27.5	65.0	132	10	104	95	-75
LRSA3-300-B02	549	558	381	389		14	168	40.5	165.5	250	325	28.0	65.5	157	10	104	121	-100

Dimensions in mm

moment load ratings + load / life formulas.
 *Travel is 1/2 distance from center in either direction.

Maximum Recommended
 Revolutions Per Second

Lead: 2mm	20 RPS
Lead: 3mm	10 RPS
Lead: 20mm	10 RPS

Posi-Drive		
MODEL	LOAD TRAVEL CAPACITY	
	mm	kg
LSA3-25-B02	25	14
LSA3-50-B02	50	16
LSA3-75-B02	75	18
LSA3-100-B02	100	20
LSA3-150-B02	150	25
LSA3-200-B02	200	27
LSA3-250-B02	250	34
LSA3-300-B02	300	41
<hr/>		
LRSA3-25-B02	25	27
LRSA3-50-B02	50	32
LRSA3-75-B02	75	36
LRSA3-100-B02	100	41
LRSA3-150-B02	150	50
LRSA3-200-B02	200	54
LRSA3-250-B02	250	68
LRSA3-300-B02	300	82

Carriage Dimensions for Posi-Drives
with 25 - 100mm of travel

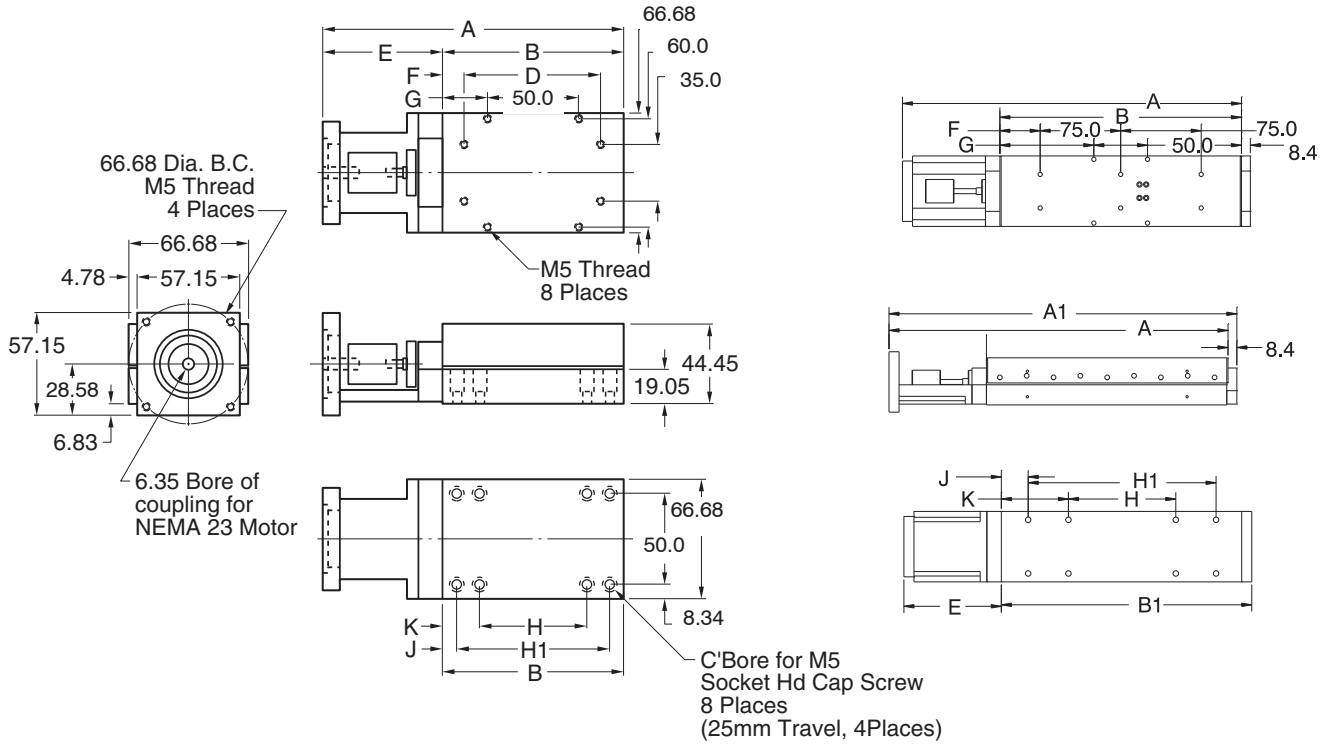

Y Axis Adaptor Plate for
150, 200, 250 & 300mm of travel

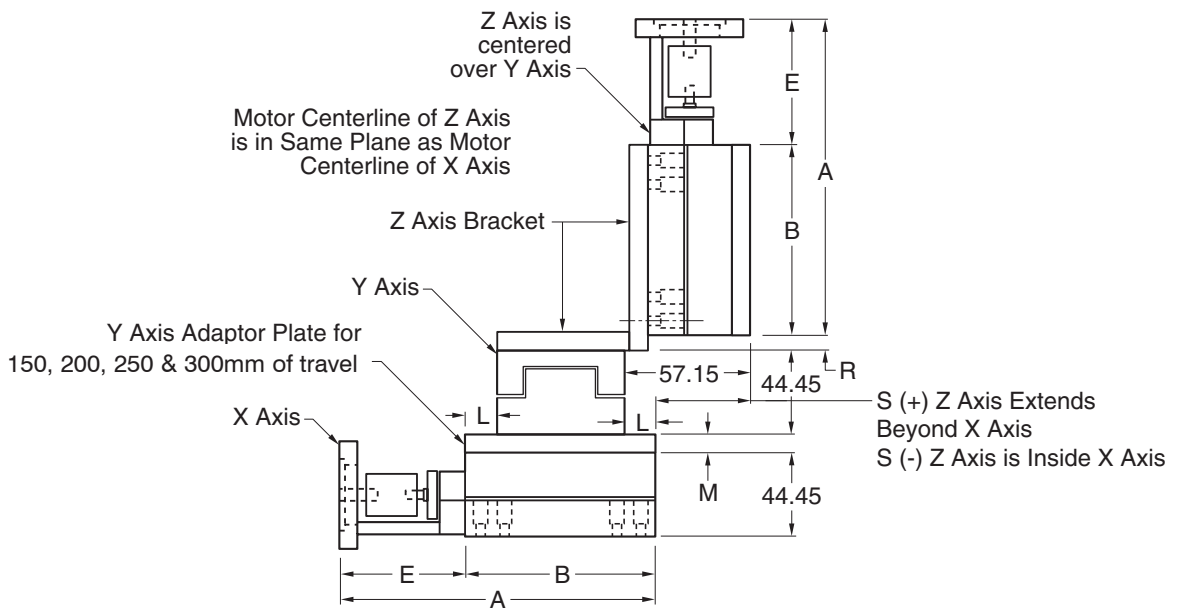
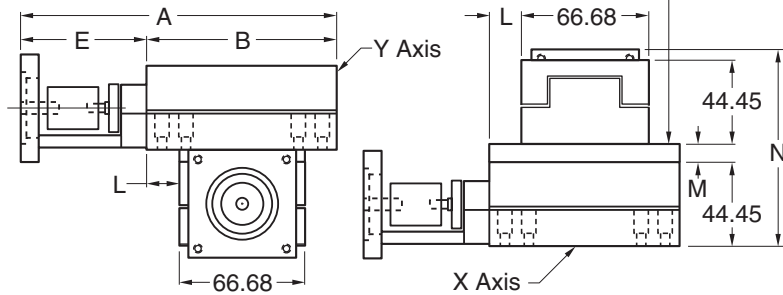

LIMIT AND POSITION SWITCHES

EOT (End Of Travel) and HPS (Home Position Switches)

Del-Tron Precision offers the addition of EOT and HPS to all 3 sizes of the Posi-Drive series. The EOT kit and the HPS kit could be used together or independently. The stand alone kits can be added to any of the 3 sizes of the Posi-Drive series. The EOT kit comes with 2 switches mounted to the base at each end. There are 2 flags that are mounted to the carriage. These flags are adjustable for either the full range of travel or for limited amount of travel if the application requires such. The Home Position Switch kit comes with 1 switch mounted to the base in the center. There is an adjustable flag mounted to the carriage. The adjustable flag will allow the Home Position to be set anywhere along the entire range of travel. The EOT and HPS are easily mounted to brackets, which are then attached to the base. The flags are easily assembled to a bracket that is then attached to the carriage. The base and carriage have the threaded mounting holes available for easy assembly of the brackets. The switches are photoelectric sensors that operate on a supply voltage of 5 to 24 VDC. The repeatability is .005mm and the response time is 100μseconds. The sensors are available in both NPN and PNP outputs. The sensors are equipped with a quick fitting Hook-Up Connector with cable lengths in 1m or 3m.

Part Numbering System for EOT and HPS

E-PNP-1
X-XXX-X

X-Configuration- E=EOT, H=HPS, EH=Combined
XXX=Type of Sensor, PNP or NPN
X=Length of Cable, 1=1meter, 3= 3 meter

Part Number

E-PNP-1
E-NPN-1
H-PNP-1
H-NPN-1
EH-PNP-1
EH-NPN-1

LSA3 and LRSA3 SERIES		
TRAVEL	B	T
25	76.2	60.33
50	101.6	85.73
75	127.0	111.13
100	152.4	136.53
150	228.6	212.73
200	279.4	263.53
250	330.2	314.33
300	381.0	365.13

Prices are the same for the 3 meter length cable and connector.

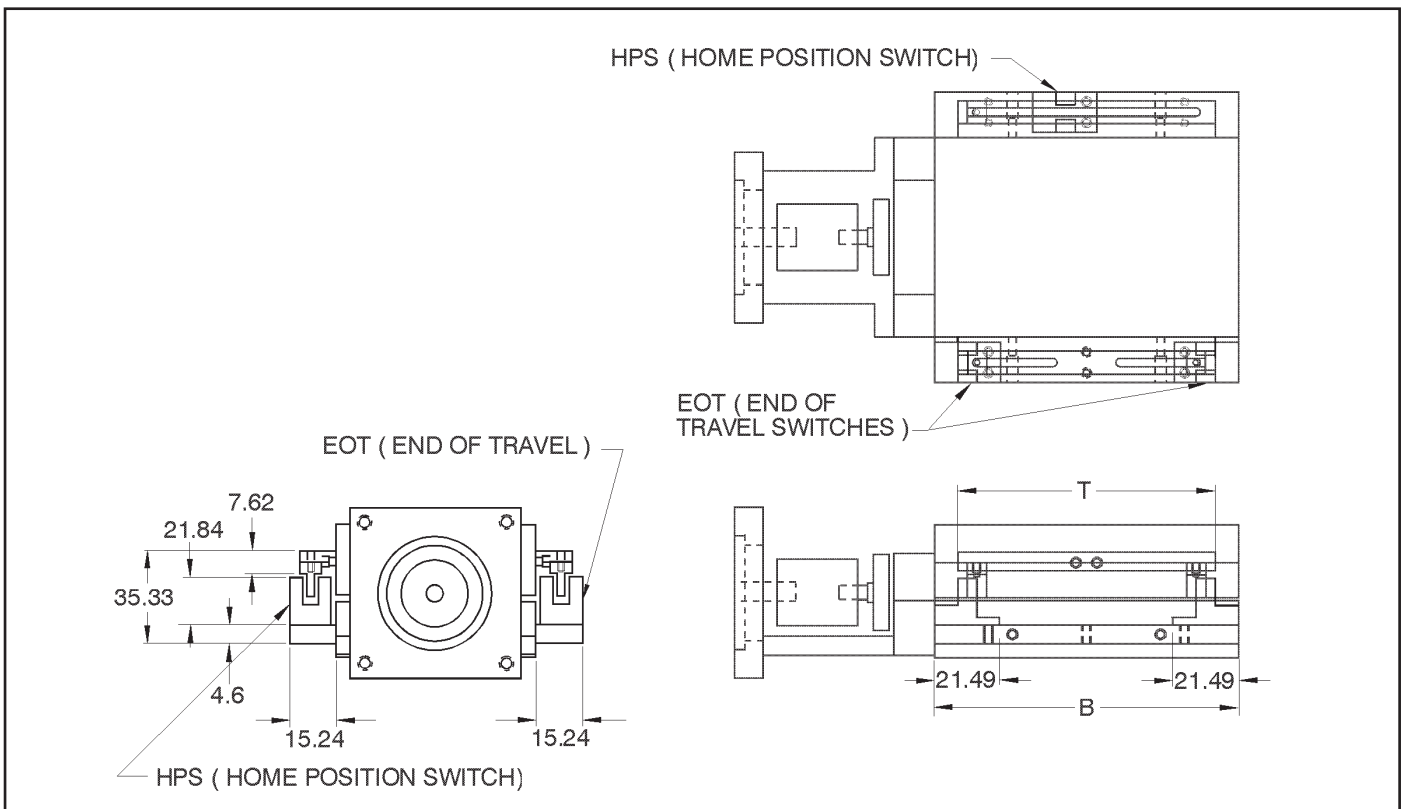

Friction Free Air Actuator

6 Reasons to choose Del-Tron® Air Actuators

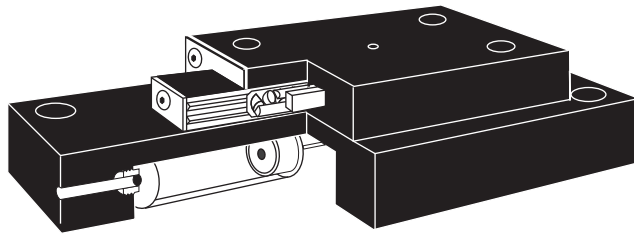

1. **Low Pressure operation: <10 PSI**
2. **Low Friction: <1gm**
3. **Wide range variable speed: smooth, slow and high speed capabilities.**
4. **Precise, gentle handling of wafers, chips and surface mount devices.**
5. **Ideal for fluid sample handling and adhesive deposition.**
6. **Del-Tron Crossed Roller Slide, driven by 2 Air Actuated Dashpots, provides a frictionless interface for up to 50mm travel in a compact package.**

Del-Tron® Air Actuators

Pneumatically actuated crossed roller slide assemblies controlled by a pair of Airpot™ actuators, provide extremely low friction and stiction characteristics. A light touch or physical obstruction will stop the unit's movement to prevent damage to delicate and expensive equipment and parts. Low pressure operation is possible. The PNRE series requires less than 10 psi to operate.

Each slide is comprised of an aluminum carriage straddling an aluminum base. Using a bearing system containing cylindrical steel rollers, the carriage glides, almost friction-free, over the base. The rollers, alternately crisscrossed with each other, move between a set of four, partially flat, parallel, smooth rods on each side of the base. The Del-Tron Straight Line Design™ makes possible the low stiction and friction characteristics Del-Trons are known for, unlike recirculating designs in which the rolling elements must turn corners and often slide against each other as they travel.

Airpot™ Pneumatic Actuators are ultra low friction devices designed to provide precise, repeatable motion at very high or low speeds without seals or lubrication. They run clean and operate over a wide temperature range with no change in performance. The basic construction consists of a graphitized carbon piston, precision ground to millionths of an inch TIR, inside an annealed, borosilicate glass cylinder with a precision fire polished bore.

Measurements in Millimeters

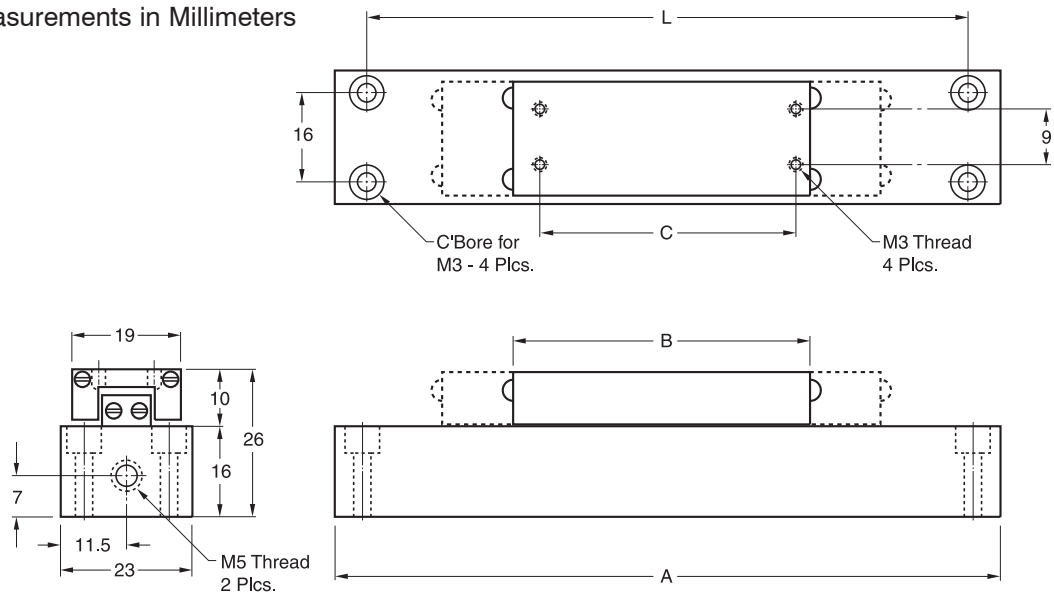

***Travel is 1/2 distance from center in either direction.**

MODEL	TRAVEL*	A	B	C	L	Load Capacity kg.
PNRE-1M	12	80	54	41	70	2.3
PNRE-2M	25	120	54	41	110	2.3
PNRE-3M	50	200	78	66	190	2.3

Ball Slide Positioning Stages (Micrometer Driven)

6 Reasons to choose Del-Tron® Ball Slide Positioning Stages

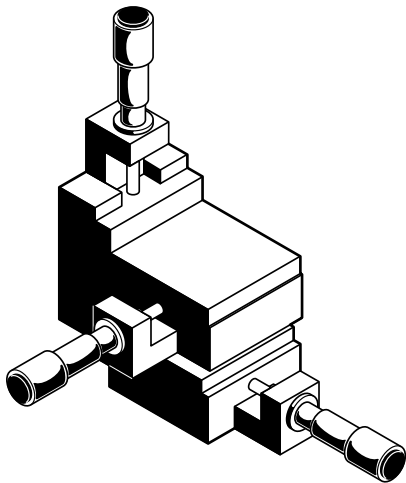

1. **Versatile-** Smooth, accurate travel for intermittent motion applications.
2. **Positive Locking-** Side mounted lock feature prevents movement of carriage.
3. **Accurate Measurements-** Carriages are spring loaded against micrometer heads with 0.01mm graduations.
4. **Adaptable-** One, two or three axis models can be used in any orientation.
5. **Easy To Use-** Standard counterbored holes in base and threaded holes in carriage.
6. **Wide Selection-** Subminiature and low profile models.

Del-Tron® Ball Slide Positioning Stages

Del-Tron® offers over 60 models of positioning slides.

Used for gaging and positioning light and medium loads, applications include measuring instruments and optical assemblies. Del-Tron® positioners, built with the same rigorous manufacturing demands as our ball slide assemblies, offer the benefits of quality construction.

Spring loaded micrometer drives allow precise repeatable adjustments with low friction and zero backlash. (Micrometers available in inch or metric units.) Slides provide accuracy to .013mm/25mm of travel and repeatability of .003mm. Over 60 models support load capacities to 27.2 kg. Our full line includes the subminiature series with the smallest commercially available positioner, the standard series, ideal for most gaging and positioning applications, and our heavy duty series providing high load capacities with the same high accuracy and repeatability.

Positioning slides can be stacked for multi-axis applications. Standard stacked units are available in XY and XYZ configurations. Preloaded positioning slides, fully assembled, arrive ready for your use.

Positioners are available in black anodized finish or other finishes on request.



Nomenclature

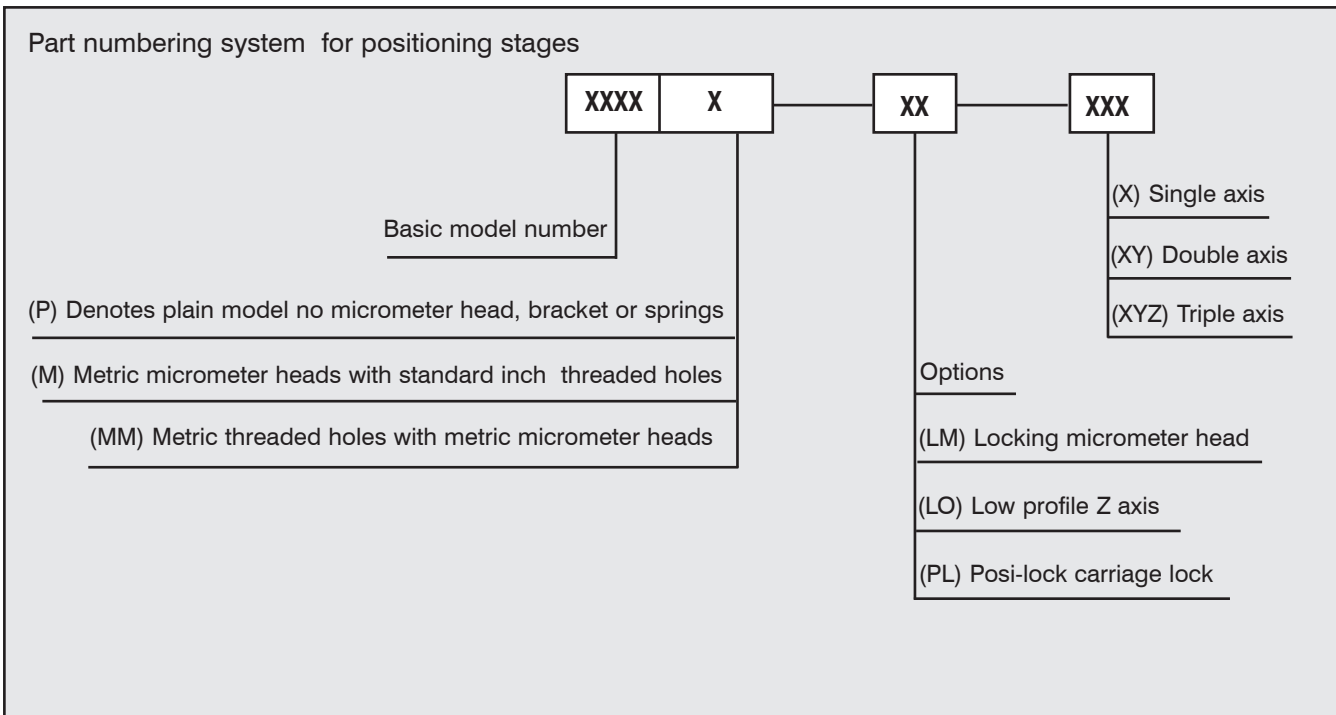

- Posi-Lock™ feature consists of steel shim and extended micrometer bracket secured by a screw mounted to the side of the stage carriage. This allows the user to positively lock the position of the carriage during use. Posi-Lock™ is standard on the model 99MM and optional on all others.
- Locking micrometer heads are available to positively lock the micrometer setting. Not available for models 99MM, 101MM, 201MM, 301MM and 50mm travel micrometers.
- Space saving side mount micrometer head style available. Please inquire.
- Loads in Z axis will extend springs if too heavy. Series 400MM, 500MM, 700MM, 1200MM, 2200MM and 3200MM have micrometer bracket reversed to prevent this and increase Z axis capacity
- Custom designs quoted on request.
- Inch threaded mounting holes optional at no cost.
- P style (plain) are free floating slides without micrometer head, brackets or springs.
- (P-PL) Plain with Posi-Lock™ available, only on 1200MM, 2200MM, & 3200MM series.

Ball Slide Positioning Stages

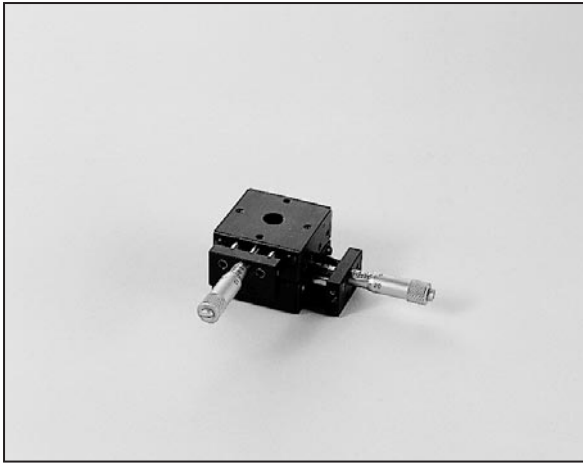

SPECIFICATIONS:

Straight Line Accuracy	.013mm/25mm of travel
Repeatability	.003mm
Coefficient	.003 typical
Construction	Aluminum carriage and base, hardened steel shafts and balls, mild steel end caps.
Finish	Black anodize standard. Other finishes on request.

moment load ratings + load / life formulas. pg.94

MODEL	TRAVEL	WORK SURFACE	OVERALL DIMENSIONS		LOAD CAPACITY, kg		THROUGH HOLE
		A X B	L	Hx	X, XY	Z	
99MM	6	19.1 x 19.1	57.9	13.5	2.3	.7	NO
101MM	13	31.8 x 31.8	82.6	9.7	1.8	.7	NO
201MM	13	44.5 x 44.5	95.3	9.7	1.8	.7	NO
301MM	13	38.1 x 38.1	88.9	15.7	5.4	.9	8 DIA.
450MM	13	44.5 x 44.5	111.3	19.1	9.1	.9	NO
451MM	25	44.5 x 44.5	149.4	19.1	9.1	.9	NO
453MM	13	44.5 x 44.5	111.3	19.1	9.1	.9	13 DIA.
750MM	13	66.5 x 66.5	133.4	25.4	27.2	.9	NO
751MM	25	66.5 x 66.5	171.5	25.4	27.2	.9	NO
753MM	13	66.5 x 66.5	133.4	25.4	27.2	.9	25 DIA.
401MM	13	50.8 x 44.5	117.3	19.1	9.1	9.0	NO
501MM	13	82.6 x 44.5	148.8	19.1	19.0	9.0	NO
502MM	25	82.6 x 44.5	188.2	19.1	19.0	9.0	NO
701MM	13	101.6 x 66.5	168.1	25.4	27.2	9.0	NO
702MM	25	101.6 x 66.5	209.6	25.4	27.2	9.0	NO
1201MM	25	79.2 x 79.2	184.2	23.1	13.6	13.6	NO
1203MM	25	79.2 x 79.2	184.2	23.1	13.6	13.6	25 DIA.
2201MM	25	104.6 x 104.6	208.6	23.1	13.6	13.6	NO
2202MM	50	104.6 x 104.6	260.4	23.1	13.6	13.6	NO
2203MM	25	104.6 x 104.6	209.6	23.1	13.6	13.6	38 DIA.
2204MM	50	104.6 x 104.6	260.4	23.1	13.6	13.6	38 DIA.
3201MM	25	130.2 x 130.2	235.0	23.1	13.6	13.6	NO
3202MM	50	130.2 x 130.2	285.8	23.1	13.6	13.6	NO
3203MM	25	130.2 x 130.2	235.0	23.1	13.6	13.6	51 DIA.
3204MM	50	130.2 x 130.2	285.8	23.1	13.6	13.6	51 DIA.
PLAIN MODELS (WITHOUT MICROMETER, BRACKETS OR SPRINGS). X AND XY CONFIGURATIONS ONLY.							
101PMM	13	31.8 x 31.8	—	9.7	1.8	—	NO
201PMM	13	44.5 x 44.5	—	9.7	1.8	—	NO
301PMM	13	38.1 x 38.1	—	15.7	5.4	—	8 DIA.
451PMM	25	44.5 x 44.5	—	19.1	9.1	—	NO
452PMM	25	44.5 x 44.5	—	19.1	9.1	—	13 DIA.
751PMM	25	66.5 x 66.5	—	25.4	27.2	—	NO
752PMM	25	66.5 x 66.5	—	25.4	27.2	—	25 DIA.
1202PMM	50	79.2 x 79.2	—	23.1	13.6	—	NO
1204PMM	50	79.2 x 79.2	—	23.1	13.6	—	25 DIA.
2205PMM	75	104.6 x 104.6	—	23.1	13.6	—	NO
2206PMM	75	104.6 x 104.6	—	23.1	13.6	—	38 DIA.
3205PMM	100	130.2 x 130.2	—	23.1	13.6	—	NO
3206PMM	100	130.2 x 130.2	—	23.1	13.6	—	51 DIA.

Dimensions in mm

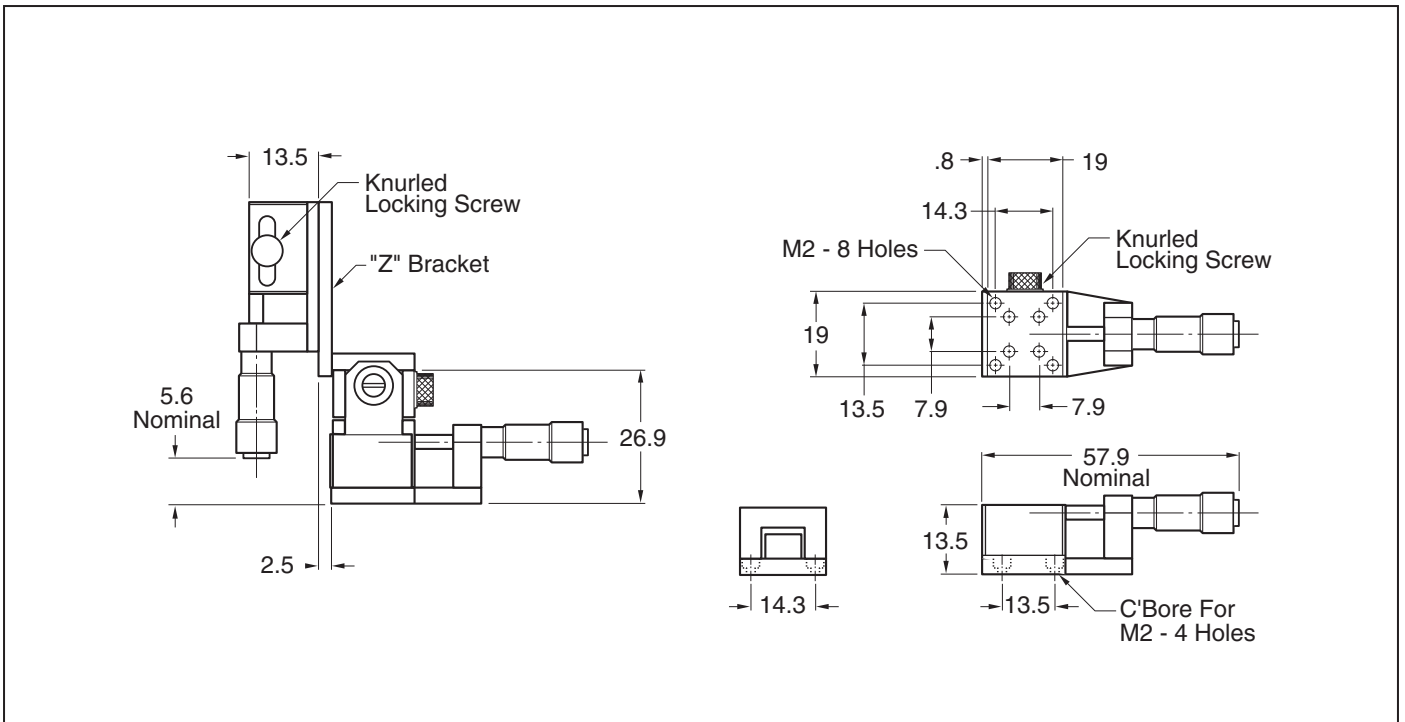

Dimensions in mm

SERIES 99MM

Space saving side mount micrometer head style is available. Please inquire.

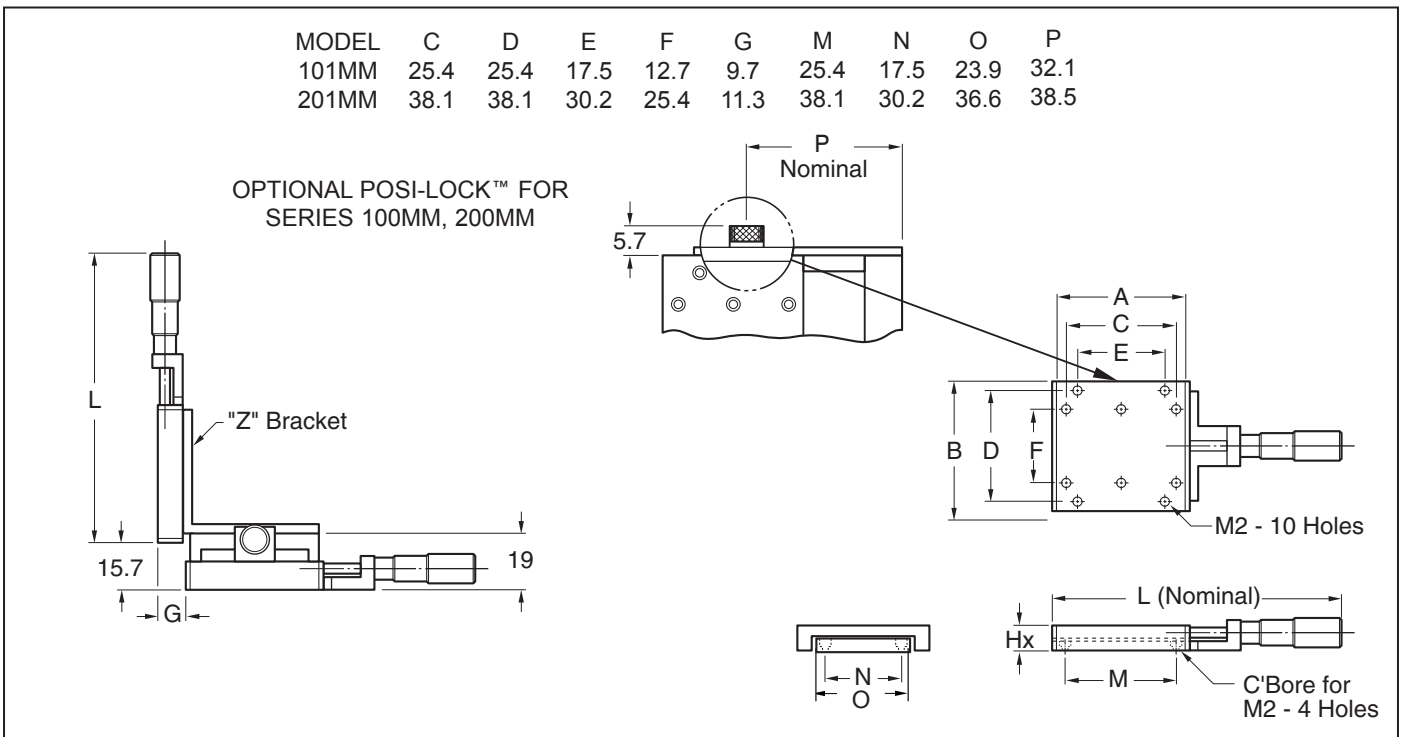

Dimensions in mm

SERIES 100MM, 200MM

SERIES	C	D	J	K	Hy	SLOT
300MM	11.2	25.4	41.1	8.1	31.8	10 x 22
450MM	17.5	28.4	50.8	—	38.1	13 x 25
750MM	17.5	38.1	66.5	1.5	50.8	25 x 38

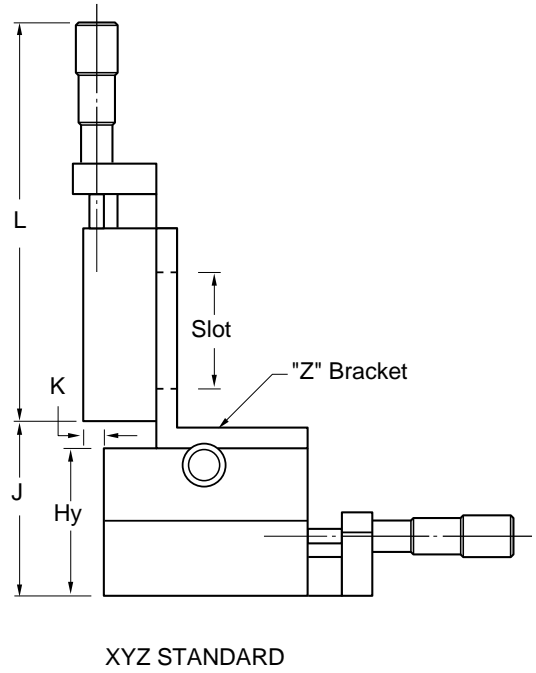
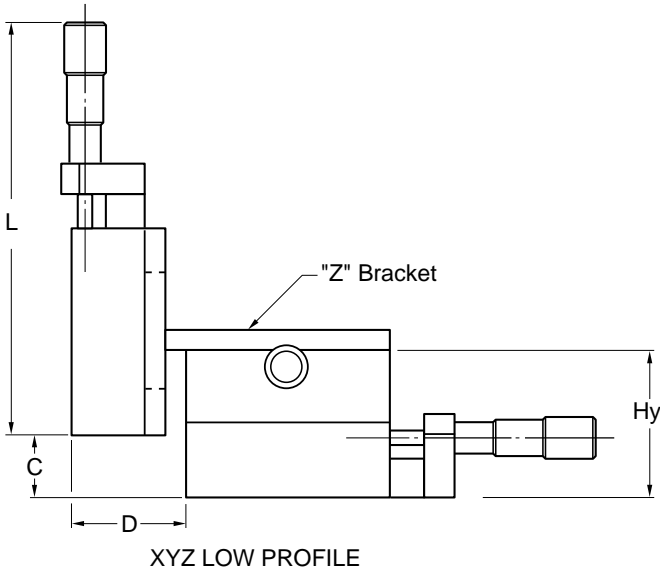

Dimensions in mm

SERIES 300MM, 450MM, 750MM

Space saving side mount micrometer head style is available. Please inquire.

SERIES	M	O	MTG. SCREW	OPTIONAL POSI-LOCK™ FOR SERIES 300MM, 450MM, 750MM	
			C'BORE	MODEL	P
300MM	30.1	22.2	M3	301MM	29.5
450MM	33.3	22.2	M4	450MM, 453MM	45.0
750MM	50.8	38.1	M5	451MM	60.7
				750MM, 753MM	45.5
				751MM	60.7

SERIES 300MM

SERIES 450MM

SERIES 750MM

Dimensions in mm

SERIES 300MM, 450MM, 750MM

SERIES	J	K	Hy	C	D	E	NO. HOLES	THREAD	C'BORE FOR	M	O
400MM	—	—	42.9	12.7	22.2	6.4	8	M4	M4	41.1	22.2
500MM	39.6	—	42.9	14.0	22.2	6.4	12	M4	M4	69.9	22.2
700MM	52.3	8.1	55.6	25.4	31.8	12.7	8	M5	M5	85.9	38.1

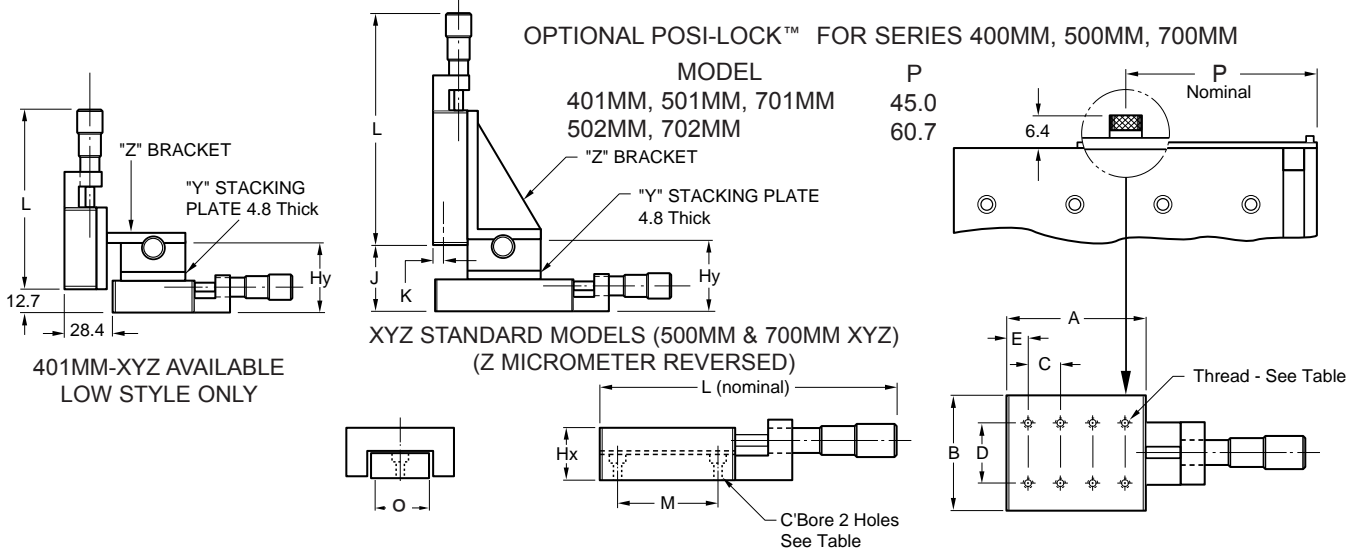

Dimensions in mm

SERIES 400MM, 500MM, 700MM

Space saving side mount micrometer head style is available. Please inquire.

SERIES	J	K	SLOT	Hy	SERIES	C	D	M	CENTER HOLE (OPTIONAL)
1200MM	65.5	8.4	25.4 x 50.8	46.2	1200MM	66.7	54.0	66.7	DIA. 25
2200MM	78.2	13.2	38.1 x 63.5	46.2	2200MM	92.1	79.4	92.1	DIA. 38
3200MM	78.2	27.7	50.8 x 101.6	46.2	3200MM	117.5	104.8	117.5	DIA. 50

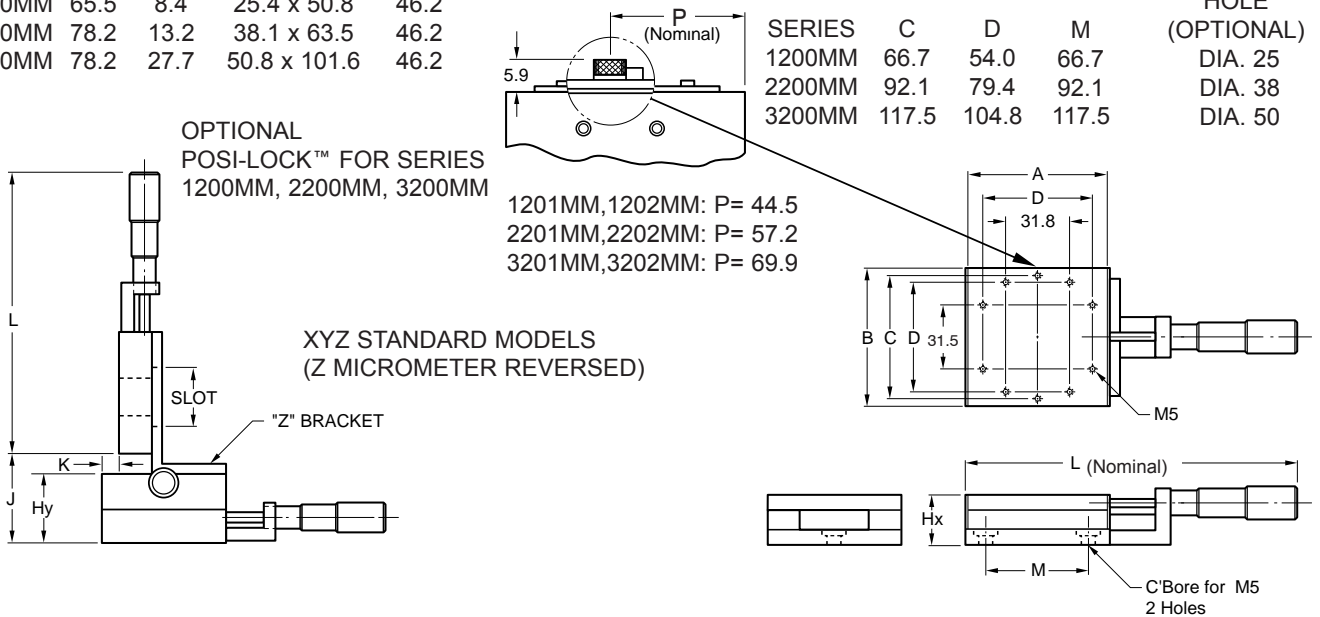

Dimensions in mm

SERIES 1200MM, 2200MM, 3200MM

Crossed Roller Positioning Stages (Micrometer Driven)

6 Reasons to choose Del-Tron® Crossed Roller Positioning Stages

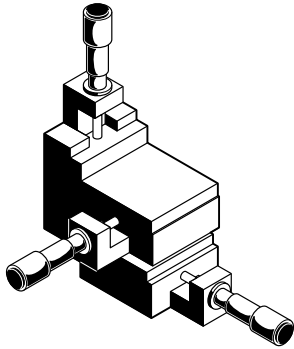

1. **High Capacity-** Greater load bearing capacity than ball types. Better for impacts and overhanging loads.
2. **Straight Line Accuracy-** Runout of .003mm/25mm of travel.
3. **Wide Range-** Carriages up to 130mm square with 50mm of travel.
4. **Smooth Accurate Movement-** Spring forces hold carriage against micrometer head. Factory adjusted preload offers friction free running.
5. **Subminiature Sizes:** R99MM among the smallest commercially available roller stages 19mm square.
6. **Positive Locking-** Posi-Lock™ feature guards against movement caused by vibration or impact.

Del-Tron® Crossed Roller Positioning Stages

Del-Tron offers over 60 models of positioning slides.

Used for gaging and positioning light and medium loads, applications include measuring instruments and optical assemblies. Del-Tron® positioners, built with the same rigorous manufacturing demands as our crossed roller slide assemblies, offer the benefits of quality construction.

Spring loaded micrometer drives allow precise repeatable adjustments with low friction and zero backlash. (Micrometers available in inch or metric units.) Slides provide accuracy to .003mm/25mm of travel and repeatability of .003mm. Over 60 models, support load capacities to 73 kg. Our full line includes the subminiature series with the smallest commercially available positioner, the standard series, ideal for most gaging and positioning applications, and our heavy duty series providing high load capacities with the same high accuracy and repeatability.

Positioning slides can be stacked for multi-axis applications. Standard stacked units are available in XY and XYZ configurations. Preloaded positioning slides, fully assembled, arrive ready for your use.

Positioners are available in black anodized finish or other finishes on request.



Nomenclature

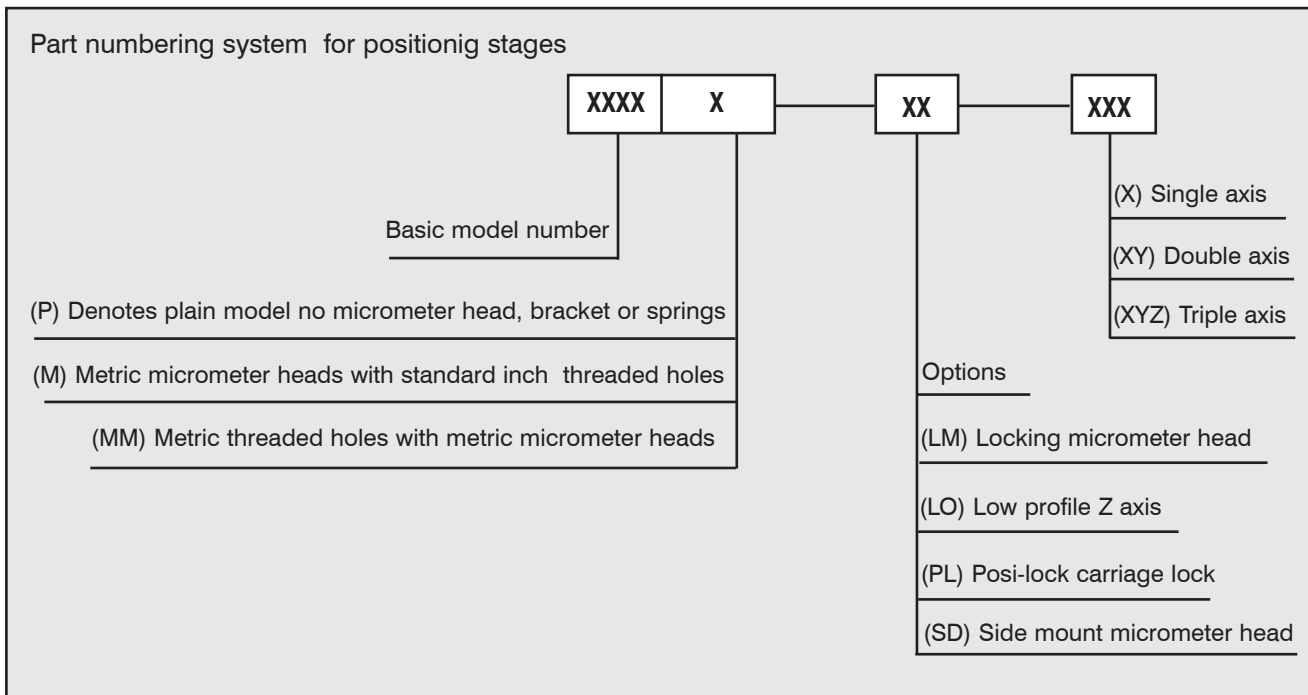

- Posi-Lock™ feature consists of a steel shim and extended micrometer bracket secured by a screw mounted to the side of the stage carriage. This allows the user to positively lock the position of the carriage during use. Posi-Lock™ is standard optional on all stages.
- Locking micrometer heads are available to positively lock the micrometer setting. Not available for models R101MM, R201MM, R301MM and 50mm travel micrometers.
- Space saving side mount micrometer head style available. Please inquire.
- Loads in Z axis will extend springs if too heavy. Series R400MM, R500MM, R700MM, R1200MM, R2200MM and R3200MM have micrometer bracket reversed to prevent this and increase Z axis capacity.
- Custom designs quoted on request.
- Inch threaded mounting holes optional at no cost.
- P style (plain) are free floating slides without micrometer head, brackets or springs.
- P-PL Plain with Posi-Lock™ available. Only on R1200MM, R2200MM, & R3200MM series.

Crossed Roller Positioning Stages

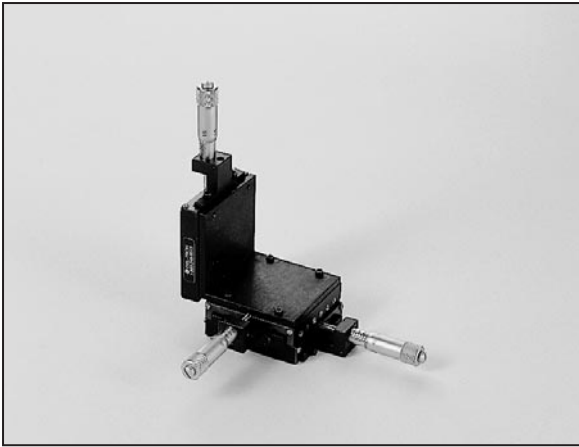

Specifications:

Straight line accuracy	.003mm/25mm of travel
Repeatability	.003mm
Coefficient of friction	0.003 typical
Drive	Micrometer, .01 mm graduations
Construction	Aluminum carriage and base, hardened steel shafts and balls, mild steel endcaps
Finish	Black anodize standard; other finishes on request

moment load ratings + load / life formulas. pg.94

MODEL	TRAVEL	WORK SURFACE	OVERALL DIMENSIONS		LOAD CAPACITY, kg		THROUGH HOLE
		A X B	L	Hx	X, XY	Z	
R99MM	6	19.1 x 19.1	57.9	13.5	18.1	.7	NO
R101MM	13	31.8 x 31.8	82.6	9.7	10.4	.7	NO
R201MM	13	44.5 x 44.5	95.3	9.7	10.4	.7	NO
R301MM	13	38.1 x 38.1	88.9	15.7	18.1	.9	8 DIA.
R450MM	13	44.5 x 44.5	111.3	19.1	18.1	.9	NO
R451MM	25	44.5 x 44.5	149.4	19.1	18.1	.9	NO
R453MM	13	44.5 x 44.5	111.3	19.1	18.1	.9	13 DIA.
R750MM	13	66.5 x 66.5	133.4	25.4	54.4	.9	NO
R751MM	25	66.5 x 66.5	171.5	25.4	54.4	.9	NO
R753MM	13	66.5 x 66.5	133.4	25.4	54.4	.9	25 DIA.
R401MM	13	50.8 x 44.5	117.3	19.1	18.1	9.0	NO
R501MM	13	82.6 x 44.5	148.8	19.1	36.3	9.0	NO
R502MM	25	82.6 x 44.5	188.2	19.1	36.3	9.0	NO
R701MM	13	101.6 x 66.5	168.1	25.4	72.5	9.0	NO
R702MM	25	101.6 x 66.5	209.6	25.4	72.5	9.0	NO
R1201MM	25	79.2 x 79.2	184.2	23.1	38.5	13.6	NO
R1203MM	25	79.2 x 79.2	184.2	23.1	38.5	13.6	25 DIA.
R2201MM	25	104.6 x 104.6	209.6	23.1	38.5	13.6	NO
R2202MM	50	104.6 x 104.6	260.4	23.1	38.5	13.6	NO
R2203MM	25	104.6 x 104.6	209.6	23.1	38.5	13.6	38 DIA.
R2204MM	50	104.6 x 104.6	260.4	23.1	38.5	13.6	38 DIA.
R3201MM	25	130.2 x 130.2	235.0	23.1	38.5	13.6	NO
R3202MM	50	130.2 x 130.2	285.8	23.1	38.5	13.6	NO
R3203MM	25	130.2 x 130.2	235.0	23.1	38.5	13.6	51 DIA.
R3204MM	50	130.2 x 130.2	285.8	23.1	38.5	13.6	51 DIA.
PLAIN MODELS (WITHOUT MICROMETER, BRACKETS OR SPRINGS), X AND XY CONFIGURATIONS ONLY.							
R101PMM	13	31.8 x 31.8	—	9.7	10.4	—	NO
R201PMM	13	44.5 x 44.5	—	9.7	10.4	—	NO
R301PMM	13	38.1 x 38.1	—	15.7	18.1	—	8 DIA.
R451PMM	25	44.5 x 44.5	—	19.1	18.1	—	NO
R452PMM	25	44.5 x 44.5	—	19.1	18.1	—	13 DIA.
R751PMM	25	66.5 x 66.5	—	25.4	54.4	—	NO
R752PMM	25	66.5 x 66.5	—	25.4	54.4	—	25 DIA.
R1202PMM	50	79.2 x 79.2	—	23.1	38.5	—	NO
R1204PMM	50	79.2 x 79.2	—	23.1	38.5	—	25 DIA.
R2205PMM	75	104.6 x 104.6	—	23.1	38.5	—	NO
R2206PMM	75	104.6 x 104.6	—	23.1	38.5	—	38 DIA.
R3205PMM	100	130.2 x 130.2	—	23.1	38.5	—	NO
R3206PMM	100	130.2 x 130.2	—	23.1	38.5	—	51 DIA.

Dimensions in mm

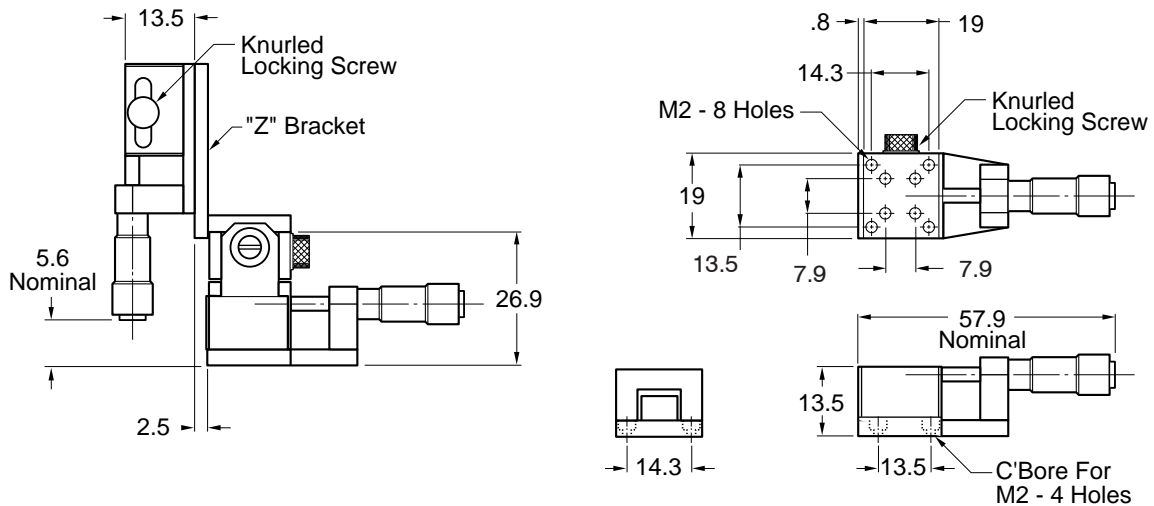

Dimensions in mm

SERIES R99MM

Space saving side mount micrometer head style is available. Please inquire.

MODEL	C	D	E	F	G	M	N	O	P
R101MM	25.4	25.4	17.5	12.7	9.7	25.4	17.5	23.9	32.1
R201MM	38.1	38.1	30.2	25.4	11.3	38.1	30.2	36.6	38.5

OPTIONAL POSI-LOCK™ FOR
SERIES R100MM, R200MM

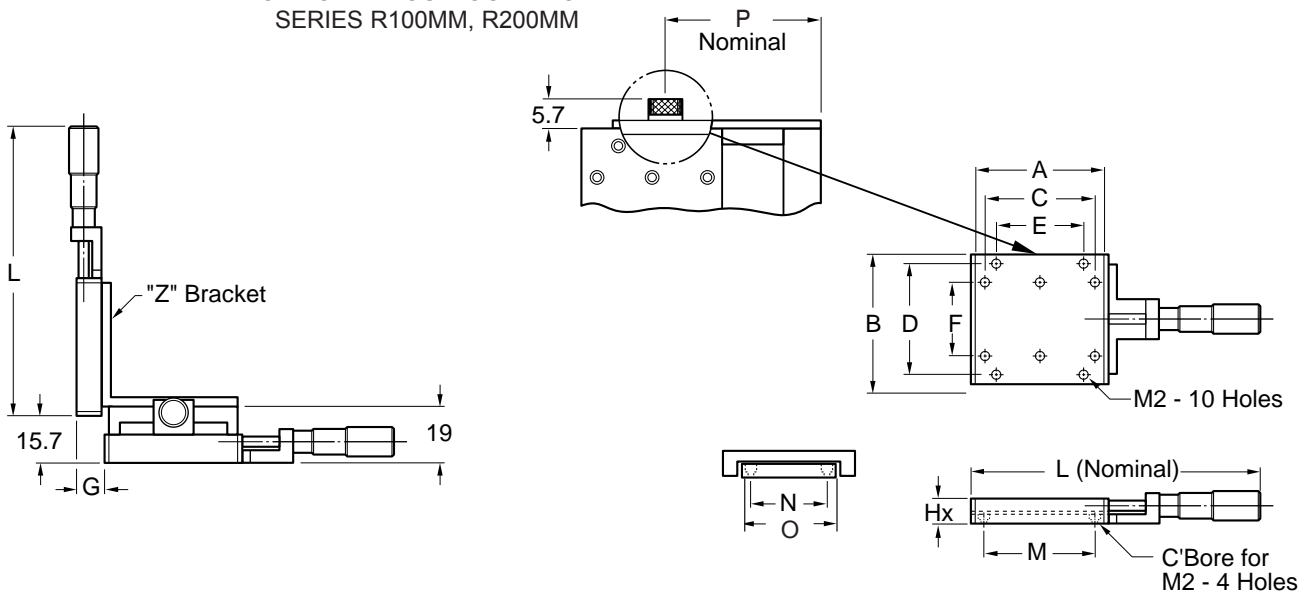

Dimensions in mm

SERIES R100MM, R200MM

SERIES	C	D	J	K	Hy	SLOT
R300MM	11.2	25.4	41.1	8.1	31.8	8 x 22
R450MM	17.5	28.4	50.8	—	38.1	13 x 25
R750MM	17.5	38.1	66.5	1.5	50.8	25 x 38

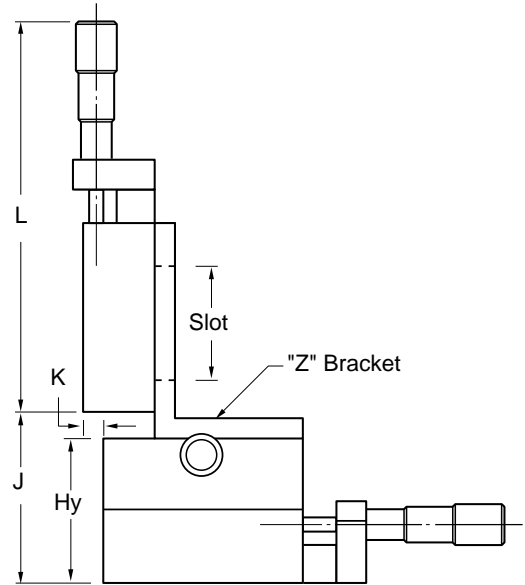
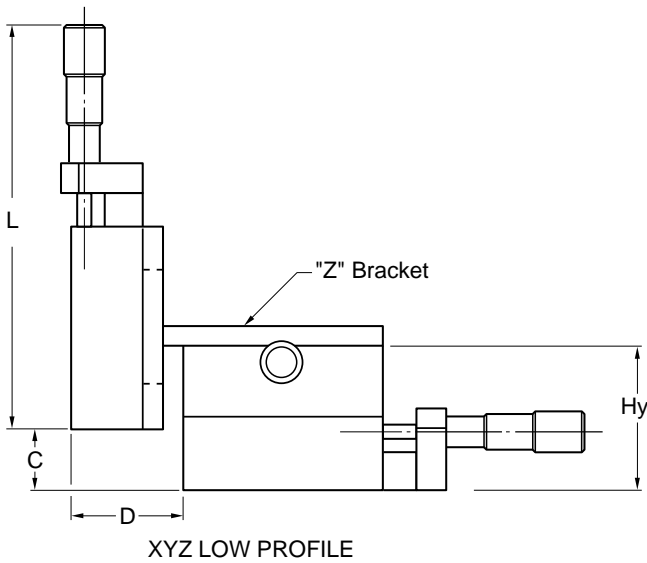

Dimensions in mm

SERIES R300MM, R450MM, R750MM

Space saving side mount micrometer head style is available. Please inquire.

SERIES	M	O	MTG. SCREW C'BORE
R300MM	30.1	22.2	M3
R450MM	33.3	22.2	M4
R750MM	50.8	38.1	M5

OPTIONAL POSI-LOCK™ FOR SERIES R300MM, R450MM, R750MM

MODEL	P
R301MM	29.5
R450MM, 453MM	45.0
R451MM	60.7
R750MM, 753MM	45.0
R751MM	60.7

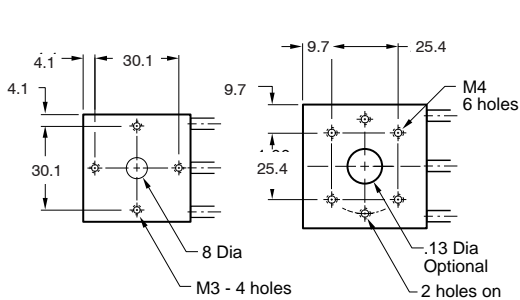

SERIES R300MM

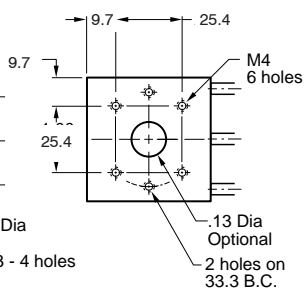

SERIES R450MM

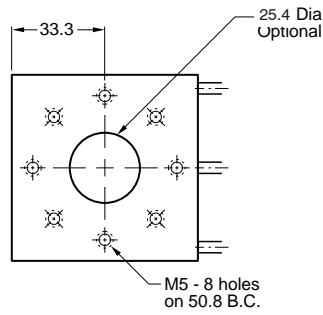

SERIES R750MM

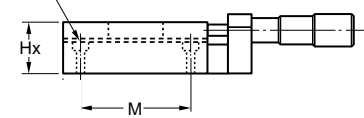
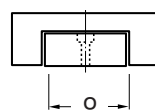
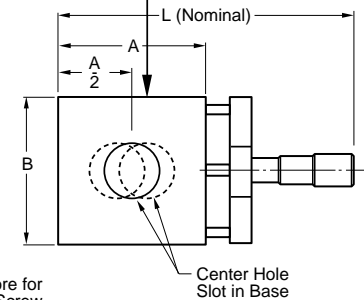
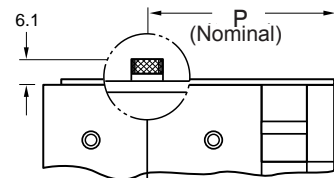

Dimensions in mm

SERIES R300MM, R450MM, R750MM

SERIES	C	D	E	NO. HOLES	THREAD	C'BORE FOR	M	O	SERIES	J	K	Hy
R400MM	12.7	22.2	6.4	8	M4	M4	41.1	22.2	R400MM	—	—	42.9
R500MM	14.0	22.2	6.4	12	M4	M4	69.9	22.2	R500MM	39.6	—	42.9
R700MM	25.4	31.8	12.7	8	M5	M5	85.9	38.1	R700MM	52.3	8.1	55.6

OPTIONAL POSI-LOCK™ FOR SERIES R400MM, R500MM, R700MM

MODEL R500MM & R700MM XYZ

MODEL	P
R401MM, R501MM, R701MM	45.0
R502MM, R702MM	60.7

MODEL R401MM-XYZ
AVAILABLE LOW STYLE ONLY

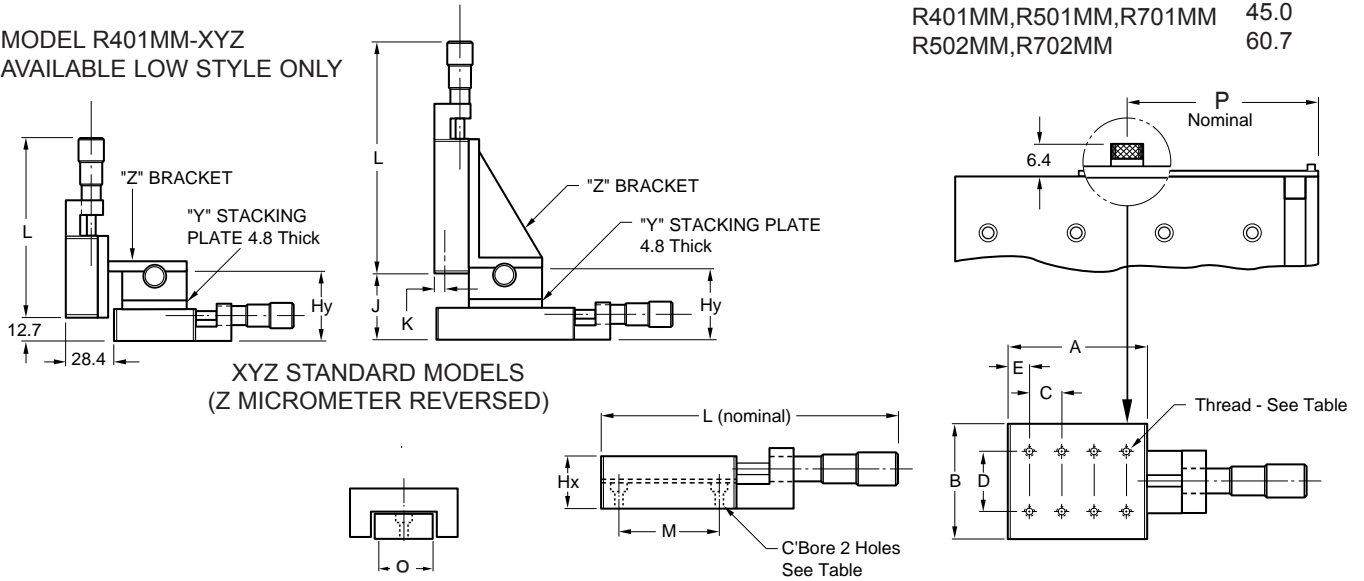

XYZ STANDARD MODELS
(Z MICROMETER REVERSED)

Dimensions in mm

SERIES R400MM, R500MM, R700MM

Space saving side mount micrometer head style is available. Please inquire.

SERIES	J	K	SLOT	Hy	CENTER HOLE (OPTIONAL)
R1200MM	65.5	8.4	25.4 x 50.8	46.2	25 Dia.
R2200MM	78.2	13.2	38.1 x 63.5	46.2	38 Dia.
R3200MM	78.2	27.7	50.8 x 101.6	46.2	50 Dia.

OPTIONAL POSI-LOCK™
FOR SERIES
R1200MM, R2200MM,
R3200MM

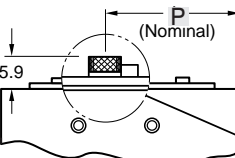

SERIES	C	D	M
R1200MM	66.7	54.0	66.7
R2200MM	92.1	79.4	92.1
R3200MM	117.5	104.8	117.5

R1201MM, R1202MM: P= 44.5
R2201MM, R2202MM: P= 57.2
R3201MM, R3202MM: P= 69.9

XYZ STANDARD MODELS
(Z MICROMETER REVERSED)

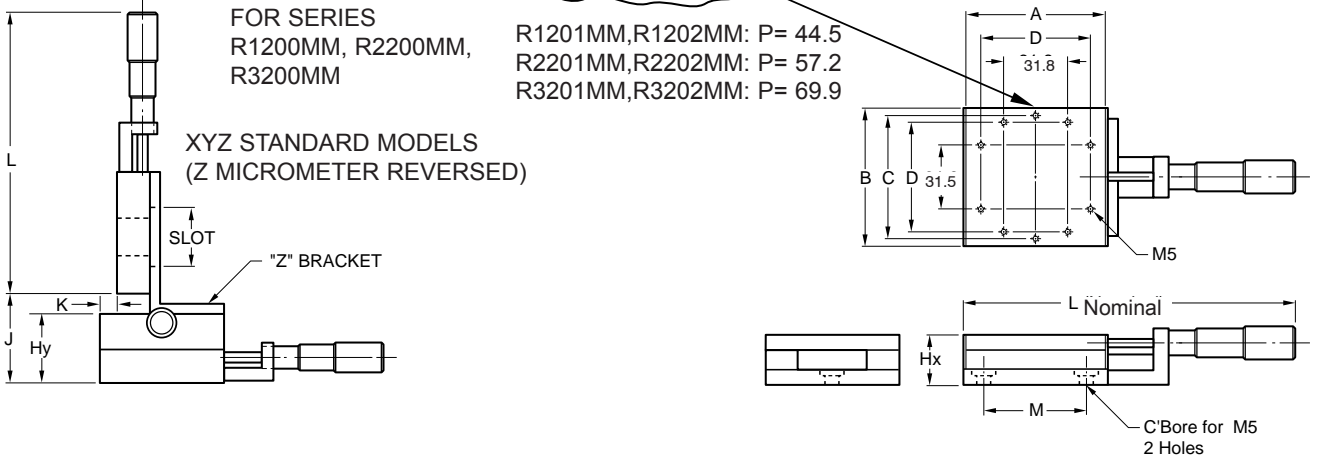

Dimensions in mm

SERIES R1200MM, R2200MM, R3200MM

Compact Side Drive Positioners

6 Reasons to choose Del-Tron® Side Drive Positioning Stages

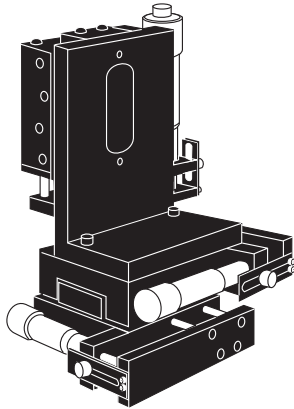

- 1. Versatile-** Reduced overall length makes Del-Tron® Side Drive stages ideal for restricted space applications.
- 2. Posi- Lock™** - Optional positive locking feature prevents movement of carriage.
- 3. Accurate Measurements:** Carriages are spring loaded against micrometer heads with 0.01mm graduations.
- 4. Adaptable-** One, two or three axis models can be used in any orientation.
- 5. Easy To Use-** Metric counterbored holes in base and metric threaded holes in carriage.
- 6. Wide Selection-** Subminiature and low profile models.

Del-Tron® Side Drive Positioning Stages

Del-Tron offers over 50 models of positioning slides. (Available in either ball bearing or crossed roller type.)

Used for gauging and positioning light and medium loads, applications include measuring instruments and optical assemblies. Del-Tron® positioners, built with the same rigorous manufacturing demands as our ball slide assemblies, offer the benefits of quality construction.

Spring loaded micrometer drives allow precise repeatable adjustments with low friction and zero backlash. (Micrometers available in inch or metric units.) Slides provide accuracy to .003mm/25mm of travel and repeatability of .003mm. Models can support load capacities to 73kg. Our full line includes the subminiature series with the smallest commercially available positioner, the standard series, ideal for most gauging and positioning applications, and our heavy duty series providing high load capacities with the same high accuracy and repeatability.

Positioning slides can be stacked for multi-axis applications. Standard stacked units are available in XY and XYZ configurations. Preloaded positioning slides, fully assembled, arrive ready for your use.

Positioners are available in black anodized finish or other finishes on request.

Nomenclature

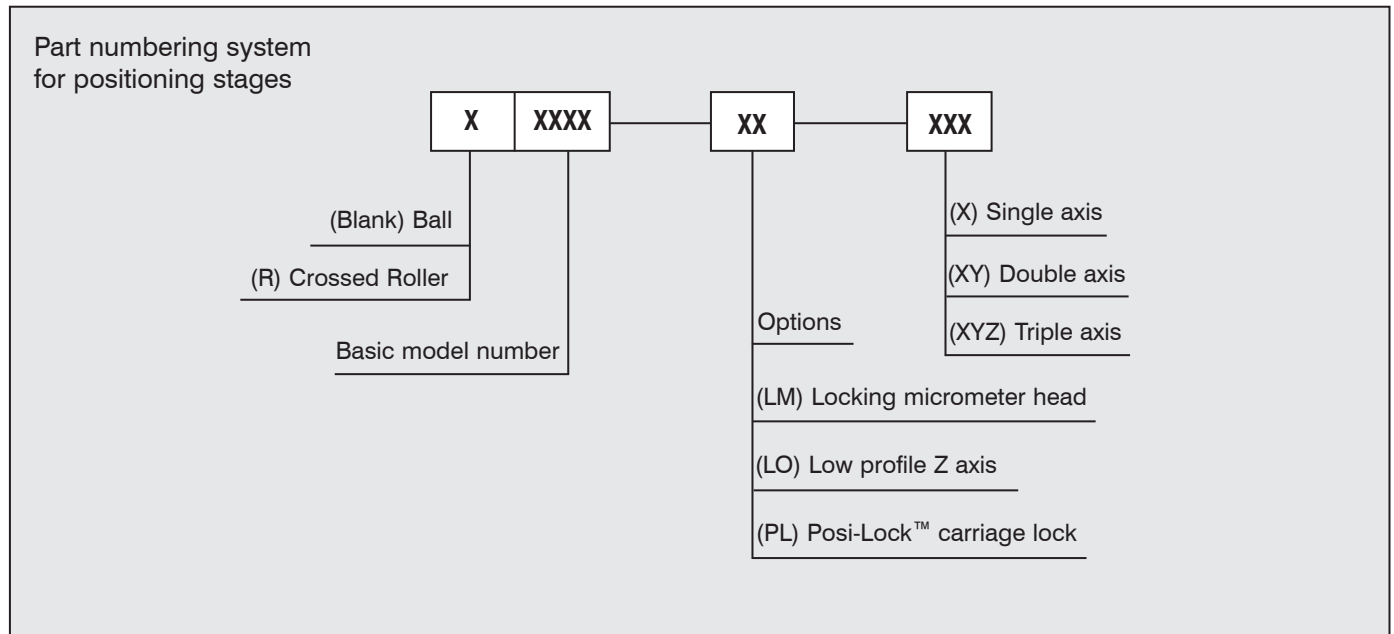

- Posi-Lock™ feature consists of steel shim and extended micrometer bracket secured by a screw mounted to the side of the micrometer bracket. This allows the user to positively lock the position of the carriage during use. Posi-Lock™ is standard on the model 99SDMM, R99SDMM and optional on all others.
- Locking micrometer heads are available to positively lock the micrometer setting. Not available for models 99SDMM, 101SDMM, 201SDMM, 301SDMM, R99SDMM, R101SDMM, R201SDMM, R301SDMM and 50mm travel micrometers.
- Custom designs quoted on request.
- Metric threaded mounting holes optional at no additional cost.



Side Drive Positioning Stages

Specifications:

Straight Line Accuracy	Ball: .013mm/25mm of travel Roller: .003mm/25mm of travel
Repeatability	Ball: .005mm Roller: .003mm
Coefficient of Friction	0.003 typical
Drive	Micrometer, .01 mm graduations standard
Construction	Aluminum carriage and base, hardened steel shafts and balls or rollers, mild steel endcaps
Finish	Black anodize standard; other finishes on request

moment load ratings + load / life formulas. pg. 94

*Travel is 1/2 distance from center in either direction.											
MODEL		TRAVEL*	WORK SURFACE	OVERALL DIMENSIONS			LOAD CAPACITY, Kg				THROUGH HOLE
Ball Slide	Crossed Roller Slide			A X B	L	Hx	W	Ball Slide		Crossed Roller Slide	
							X, XY	Z	X, XY	Z	
99SDMM	R99SDMM	6.4	19.1 x 19.1	37.6	13.5	32.7	2.3	1.1	18.1	9	NO
101SDMM	R101SDMM	13	31.8 x 31.8	54.9	9.7	44.5	1.8	.9	10.4	5.2	NO
201SDMM	R201SDMM	13	44.5 x 44.5	61.5	9.7	57.4	1.8	.9	10.4	5.2	NO
301SDMM	R301SDMM	13	38.1 x 38.1	55.4	15.7	51.1	5.4	2.7	18.1	9	8 DIA.
450SDMM	R450SDMM	13	44.5 x 44.5	74.9	19.1	61.0	9.1	4.5	18.1	9	NO
451SDMM	R451SDMM	25	44.5 x 44.5	114.5	19.1	64.8	9.1	4.5	18.1	9	NO
453SDMM	R453SDMM	13	44.5 x 44.5	74.9	19.1	61.0	9.1	4.5	18.1	9	13 DIA.
750SDMM	R750SDMM	13	66.5 x 66.5	89.4	25.4	83.1	27.2	13.6	54.4	27.2	NO
751SDMM	R751SDMM	25	66.5 x 66.5	113.8	25.4	87.1	27.2	13.6	54.4	27.2	NO
753SDMM	R753SDMM	13	66.5 x 66.5	89.4	25.4	83.1	27.2	13.6	54.4	27.2	25 DIA.
401SDMM	R401SDMM	13	50.8 x 44.5	74.9	19.1	61.0	9.1	9.0	18.1	9.0	NO
501SDMM	R501SDMM	13	82.6 x 44.5	105.4	19.1	61.0	19.0	9.0	36.3	18	NO
502SDMM	R502SDMM	25	82.6 x 44.5	114.5	19.1	64.8	19.0	9.0	36.3	18	NO
701SDMM	R701SDMM	13	101.6 x 66.5	124.5	25.4	84.1	27.2	13.6	72.5	36.2	NO
702SDMM	R702SDMM	25	101.6 x 66.5	131.6	25.4	87.1	27.2	13.6	72.5	36.2	NO
1201SDMM	R1201SDMM	25	79.2 x 79.2	120.7	23.1	102.6	13.6	13.6	38.5	38.5	NO
1203SDMM	R1203SDMM	25	79.2 x 79.2	120.7	23.1	102.6	13.6	13.6	38.5	38.5	25 DIA.
2201SDMM	R2201SDMM	25	104.6 x 104.6	120.7	23.1	128.0	13.6	13.6	38.5	38.5	NO
2202SDMM	R2202SDMM	50	104.6 x 104.6	171.7	23.1	128.0	13.6	13.6	38.5	38.5	NO
2203SDMM	R2203SDMM	25	104.6 x 104.6	120.7	23.1	128.0	13.6	13.6	38.5	38.5	38 DIA.
2204SDMM	R2204SDMM	50	104.6 x 104.6	171.7	23.1	128.0	13.6	13.6	38.5	38.5	38 DIA.
3201SDMM	R3201SDMM	25	130.0 x 130.0	130.0	23.1	153.4	13.6	13.6	38.5	38.5	NO
3202SDMM	R3202SDMM	50	130.0 x 130.0	171.7	23.1	153.4	13.6	13.6	38.5	38.5	NO
3203SDMM	R3203SDMM	25	130.0 x 130.0	130.0	23.1	153.4	13.6	13.6	38.5	38.5	51 DIA.
3204SDMM	R3204SDMM	50	130.0 x 130.0	171.7	23.1	153.4	13.6	13.6	38.5	38.5	51 DIA.

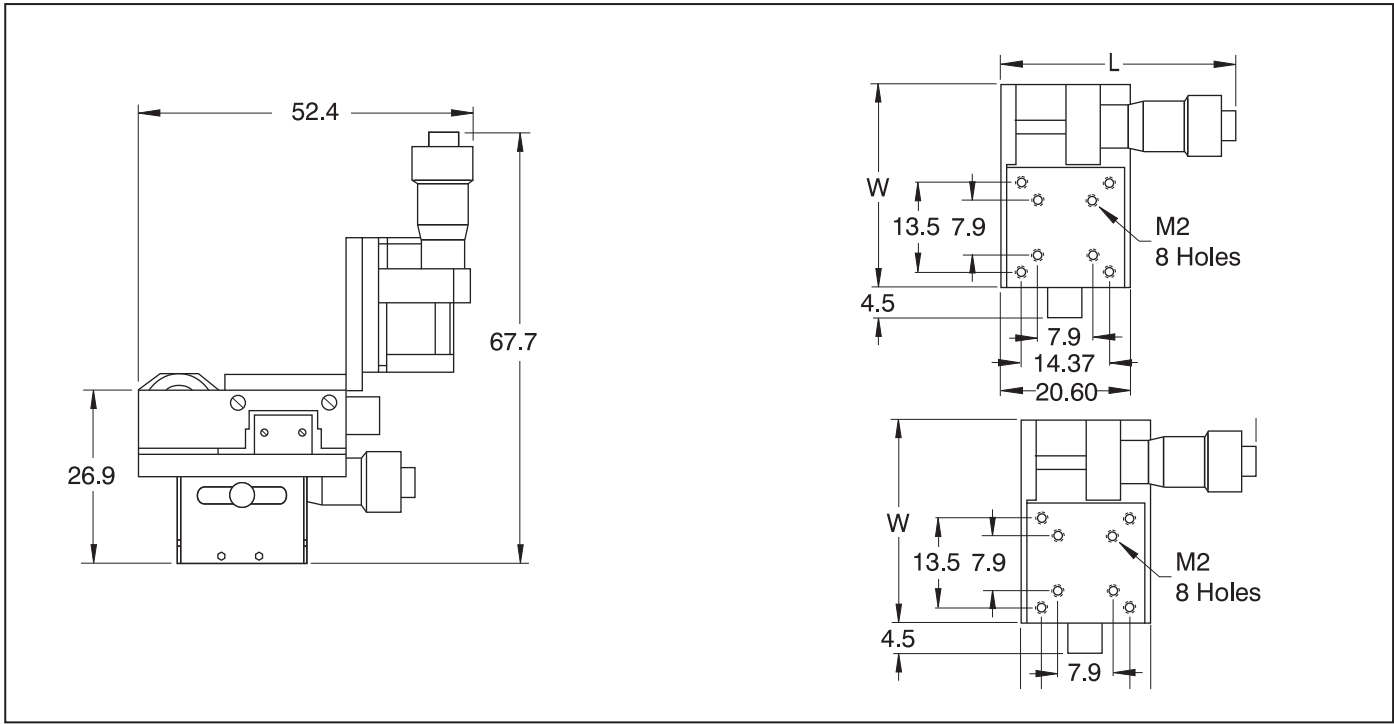

Dimensions in mm

SERIES 99SDMM, R99SDMM

MODEL		G	
101SDMM, R101SDMM	XYZ	9.7	
201SDMM, R201SDMM	XYZ	11.2	

**OPTIONAL POSI-LOCK™
FOR SERIES 100SDMM, 200SDMM,
R100SDMM, R200SDMM**

BALL SERIES	ROLLER SERIES	C	D	E	F	M	N	O	P
100SDMM	R100SDMM	25.4	25.4	17.5	12.7	25.4	17.5	23.9	15.5
200SDMM	R200SDMM	38.1	38.1	30.2	25.4	38.1	30.2	36.6	15.5

Dimensions in mm

SERIES 100SDMM, 200SDMM, R100SDMM, R200SDMM

BALL SERIES	ROLLER SERIES	C	D	J	K	Hy	SLOT
300SDMM	R300SDMM	11.2	25.4	38.1	8.0	31.8	9.7 x 22.4
450SDMM	R450SDMM	17.5	28.5	—	—	38.1	12.7 x 25.4
750SDMM	R750SDMM	23.9	38.1	66.5	7.6	50.8	25.4 x 38.1

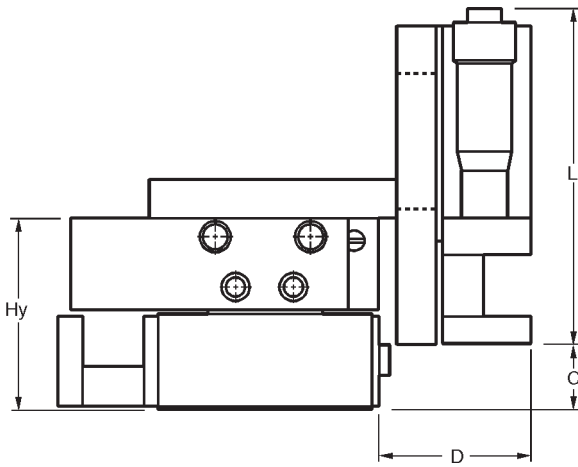

XYZ LOW PROFILE

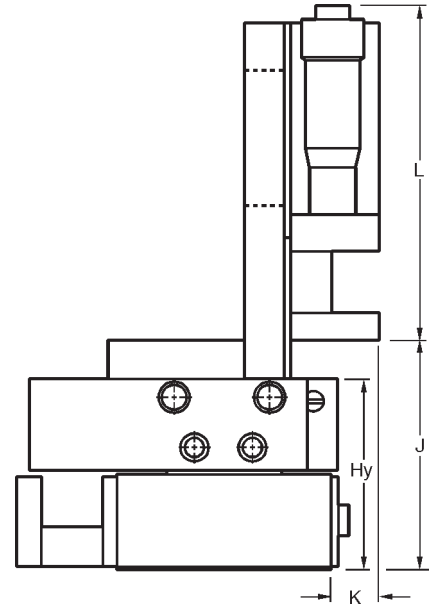

XYZ STANDARD

SERIES 300SDMM, 450SDMM, 750SDMM, R300SDMM, R450SDMM, R750SDMM

BALL SERIES	ROLLER SERIES	M	O	MTG. SCREW C'BORE
300SDMM	R300SDMM	30.2	22.2	M3
450SDMM	R450SDMM	33.3	22.2	M4
750SDMM	R750SDMM	50.8	38.1	M5

BALL SERIES	ROLLER SERIES	P
301SDMM	R301SDMM	16.0
450SDMM	R450SDMM	25.6
451SDMM	R451SDMM	25.6
453SDMM	R453SDMM	25.6
750SDMM	R750SDMM	26.1
751SDMM	R751SDMM	38.2
753SDMM	R753SDMM	38.2

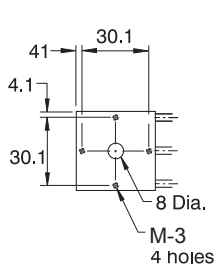

SERIES 300SDMM, R300SDMM

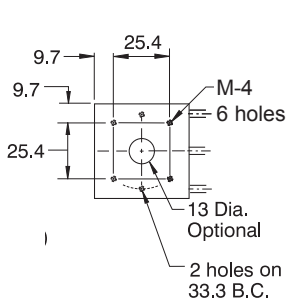

SERIES 450SDMM, R450SDMM

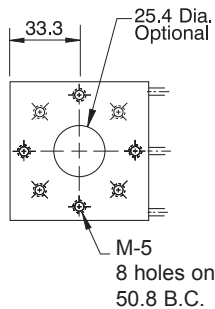

SERIES 750SDMM, R750SDMM

OPTIONAL POSI-LOCK™ FOR SERIES 300SDMM, 450SDMM, 750SDMM, R300SDMM, R450SDMM, R750SDMM

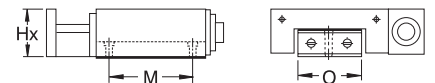
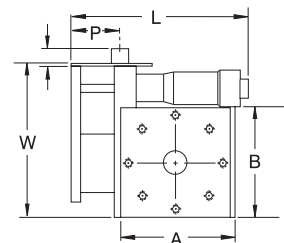

SERIES 300SDMM, 450SDMM, 750SDMM, R300SDMM, R450SDMM, R750SDMM

ROLLER SERIES	ROLLER SERIES	J	K	Hy	C	D	E	NO. HOLES	THREAD	C'BORE FOR	M	O	MODEL	MODEL	P
400SDMM	R400SDMM	49.3	14.6	42.9	12.7	22.2	6.4	8	M4	M4	41.1	22.2	401SDMM	R401SDMM	25.6
500SDMM	R500SDMM	49.3	-	42.9	13.9	22.2	6.4	12	M4	M4	69.9	22.2	502SDMM	R502SDMM	38.2
700SDMM	R700SDMM	65.0	9.3	55.6	25.4	31.8	12.7	8	M5	M5	85.9	38.1	701SDMM	R701SDMM	26.1
													702SDMM	R702SDMM	38.2

OPTIONAL POSI-LOCK™ FOR SERIES 400SDMM, 500SDMM, 700SDMM, R400SDMM, R500SDMM, R700SDMM

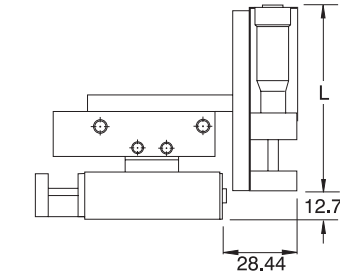

401SDMM-XYZ, R401SDMM-XYZ AVAILABLE LOW STYLE ONLY

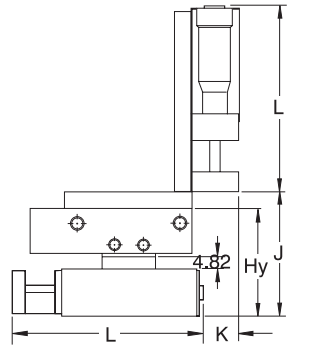

XYZ STANDARD MODELS

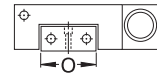
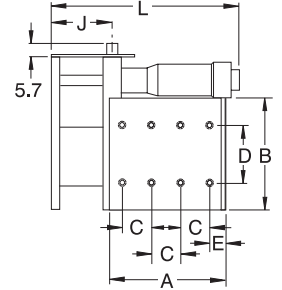
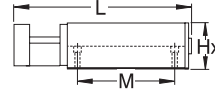
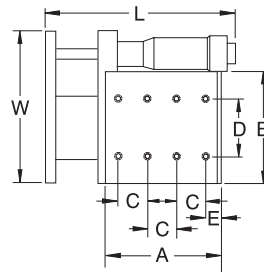

SERIES 400SDMM, 500SDMM, 700SDMM, R400SDMM, R500SDMM, R700SDMM

BALL SERIES	ROLLER SERIES	J	K	SLOT	Hy	C	D	M	P	CENTER HOLE (OPTIONAL)
1200SDMM	R1200SDMM	65.5	8.4	25.4 x 50.8	46.2	66.7	54.0	66.7	44.5	25MM DIA
2200SDMM	R2200SDMM	78.2	13.2	38.1 x 63.5	46.2	92.1	79.4	92.1	55.6	38MM DIA
3200SDMM	R3200SDMM	78.2	27.7	50.8 x 101.6	46.2	117.5	104.8	117.5	69.9	50MM DIA

OPTIONAL POSI-LOCK™ FOR SERIES 1200SDMM, 2200SDMM, 3200SDMM, R1200SDMM, R2200SDMM, R3200SDMM

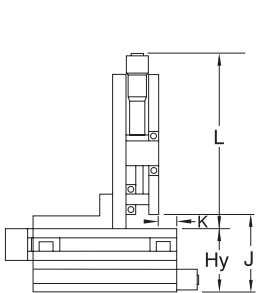

XYZ STANDARD MODELS

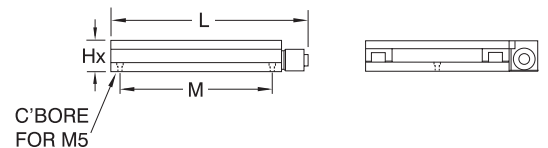
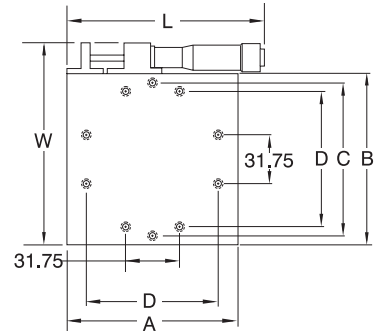
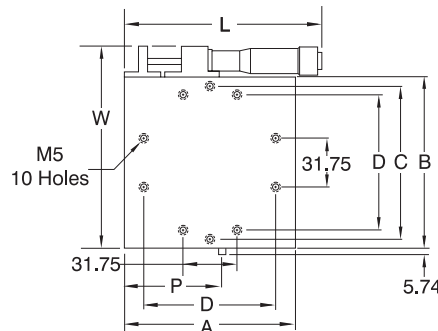

SERIES 1200SDMM, 2200SDMM, 3200SDMM, R1200SDMM, R2200SDMM, R3200SDMM

Low Profile Crossed Roller Slide Tables

6 Reasons to choose Del-Tron® Low Profile Crossed Roller Slide Tables

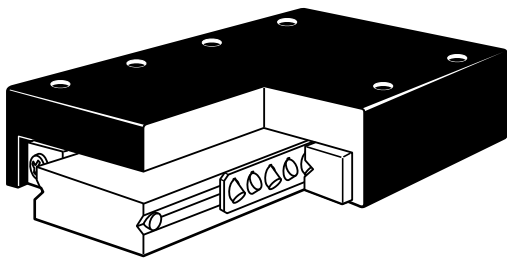

1. Compact & Low Profile.
2. High Accuracy (.003mm/25mm) Travel.
3. Metric Type Mounting Holes.
4. Light Weight Aluminum Carriage.
5. Stainless Steel Models Available.
6. 21 Size & Travel Combinations.

Low Profile Slide Tables

Del-Tron® LPTA slides are low profile, high accuracy slide tables featuring easily adjustable preload and light weight aluminum carriage. Standard metric type threaded holes allow easy mounting and installation. The bearing base consists of a two sided single inner rail flanked by two precision V grooved outer rails. High precision rollers captive in a stainless steel cage and positive internal travel stops assure smooth accurate reciprocating motion.

Stainless steel models (ss) offer aluminum carriage with stainless steel rails, rollers, cages and fasteners.

LPTA slides are ideal anywhere low friction reciprocating mechanisms are used in automated equipment.



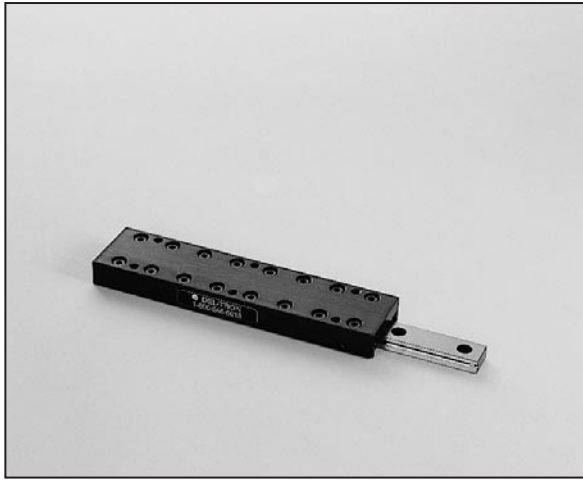

Low Profile Crossed Roller Tables

Specifications:

Straight Line Accuracy	.003mm/25mm of travel.
Positional Repeatability	.003mm
Coefficient of Friction	0.003 typical
Construction	Aluminum carriage, hardened steel crossed roller rail set with double v-grooved inner rail.
Finish	Black anodized carriage, hardened steel base.

BASE MOUNTING DIMENSIONS

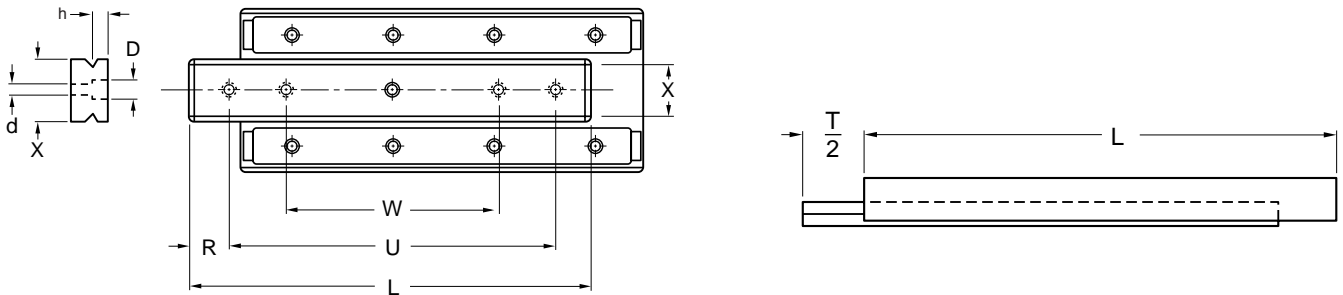

Length, Travel, and Load Selection

moment load ratings + load / life formulas. pg.95

MODEL	STAINLESS STEEL	TRAVEL T	LENGTH L	LOAD CAPACITY kgf	BASE MOUNTING HOLES (COUNTERBORED)			CARRIAGE MOUNTING HOLES (THREADED)	
					NO. HOLES	SPACING U	W	NO. HOLES	SPACING M
LPTA-1025	SS	12	25	23	2	18	—	4	18
LPTA-1035	SS	18	35	32	2	25	—	4	1 x 28
LPTA-1045	SS	25	45	47	4	38	25	4	1 x 20
LPTA-1055	SS	32	55	54	4	48	29	4	1 x 30
LPTA-1065	SS	40	65	60	4	55	31	6	2 x 20
LPTA-1075	SS	45	75	73	4	65	35	4	1 x 30
LPTA-1085	SS	50	85	79	4	75	40	6	2 x 30
LPTA-2035	SS	18	35	40	2	25	—	4	1 x 28
LPTA-2050	SS	30	50	63	2	35	—	4	1 x 43
LPTA-2065	SS	40	65	75	4	55	33	4	1 x 30
LPTA-2080	SS	50	80	95	4	70	40	4	1 x 45
LPTA-2095	SS	60	95	105	4	85	45	6	2 x 30
LPTA-2110	SS	70	110	120	4	95	50	4	1 x 45
LPTA-2125	SS	80	125	130	4	110	55	6	2 x 45
LPTA-3055	SS	30	55	126	2	40	—	4	1 x 40
LPTA-3080	SS	45	80	183	4	68	43	4	1 x 65
LPTA-3105	SS	60	105	220	4	90	55	4	1 x 50
LPTA-3130	SS	75	130	275	4	115	65	4	1 x 75
LPTA-3155	SS	90	155	310	4	140	95	6	2 x 50
LPTA-3180	SS	105	180	355	4	165	85	4	1 x 75
LPTA-3205	SS	130	205	375	4	190	90	6	2 x 75

Dimensions in mm

Mounting Dimensions								
SERIES	CARRIAGE				BASE			
	SPACING N	SPACING P	THREAD J	DEPTH K	SPACING R	D	COUNTERBORE d	h
LPTA-1025	3.5	14	M2	3.5	3.5	3.9	2.6	2.5
LPTA-1035	3.5	—	—	—	5	—	—	2.5
LPTA-1045	12.5	—	—	—	3.5	—	—	2.5
LPTA-1055	12.5	—	—	—	3.5	—	C'BORE FOR M2	2.5
LPTA-1065	12.5	—	—	—	5	—	—	2.5
LPTA-1075	22.5	—	—	—	5	—	—	2.5
LPTA-1085	12.5	—	—	—	5	—	—	2.5
LPTA-2035	3.5	22	M4	5.5	5	6.1	4	3.8
LPTA-2050	3.5	—	—	—	7.5	—	—	3.8
LPTA-2065	17.5	—	—	—	5	—	C'BORE FOR M3	3.8
LPTA-2080	17.5	—	—	—	5	—	—	3.8
LPTA-2095	17.5	—	—	—	5	—	—	3.8
LPTA-2110	32.5	—	—	—	7.5	—	—	3.8
LPTA-2125	17.5	—	—	—	7.5	—	—	3.8
LPTA-3055	7.5	30	M5	7.5	7.5	8.3	5.2	5.2
LPTA-3080	7.5	—	—	—	6	—	—	5.2
LPTA-3105	27.5	—	—	—	7.5	—	C'BORE FOR M4	5.2
LPTA-3130	27.5	—	—	—	7.5	—	—	5.2
LPTA-3155	27.5	—	—	—	7.5	—	—	5.2
LPTA-3180	52.5	—	—	—	7.5	—	—	5.2
LPTA-3205	27.5	—	—	—	7.5	—	—	5.2

Dimensions in mm

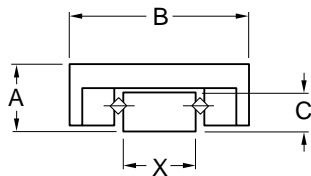

Profile Dimensions				
SERIES	HEIGHT A ±0.1	WIDTH B ±0.1	BASE THICKNESS C	BASE WIDTH X
LPTA-1000	8	20	4	6.6
LPTA-2000	12	30	6	12
LPTA-3000	16	40	8	16

Dimensions in mm

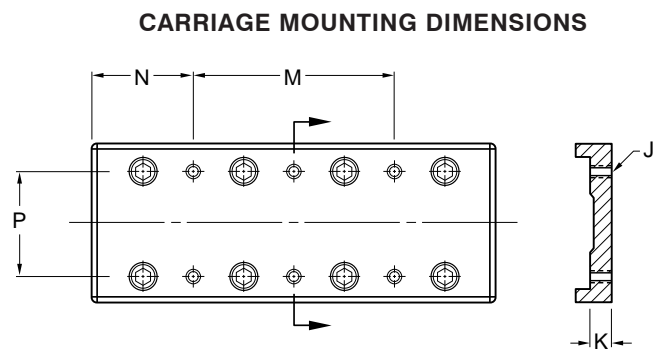

Crossed Roller Rail Sets

6 Reasons to choose Del-Tron® Crossed Roller Rail Sets

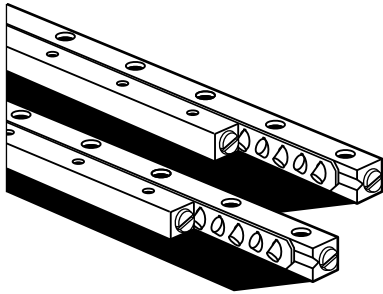

1. **Versatile-** May be adapted to your own base and carriage design.
2. **Rugged-** Hardened steel v-grooved rails and rollers withstand heavy loads and impacts.
3. **Corrosion Resistant-** Stainless steel available from stock.
4. **High Accuracy-** Parallelism of 0.002mm over 100mm.
5. **Easy To Use-** Standard threaded and counterbored mounting holes allow access from either side.
6. **Interchangeable-** Form, fit and functional replacement for other manufacturer's rails.

Del-Tron® Crossed Roller Rail Sets

Crossed Roller Linear Bearings are compact, precision bearings that can support and guide high loads with high accuracy and repeatability, low friction, and low starting force. A complete range of sizes is supplied for use in precision machine tools, measuring instruments, assembly fixtures, medical instruments, and anywhere linear or reciprocating motion with high reliability and long life is required.

Construction

Each bearing consists of a pair of hardened steel ways containing 90° vee grooves, and a row of alternately crossed cylindrical rollers. The hardened steel rollers are captive in a stainless steel cage for easy handling and assembly and permanent alignment. The ways are installed face to face by the user, with the rollers between the vee grooves.

Stainless Steel also available.

Application

Bearings are normally supplied and installed in sets of two to form an assembly that can support their rated load in any direction or orientation, and can be preloaded to eliminate side play.

Mounting and banking surfaces must be smooth and flat, and accurately parallel, coplanar, or perpendicular respectively to achieve maximum accuracy. Preload forces must be evenly distributed. Dirt and dust must be excluded. Lubrication required depends on the application, ranging from light grease or oil at the time of installation for low speeds (less than 1270mm/min.) and occasional movement to continuous oil bath or mist at 30,000mm/min.



Ratings and Specifications

Load ratings in the tables are dynamic ratings for each set. Ratings are based on theoretical data, proper installation, appropriate lubrication, and a predicted life of 250 million mm. Ratings are suggested only, based on standard and typical industry practice, and cannot be guaranteed. Life can be increased approximately 10 times by operating a given bearing at 1/2 its rated load, other factors being constant. Temperature of bearings must not exceed 100°C, even for short periods, since this will reduce hardness and result in significantly reduced load capacity and working life.

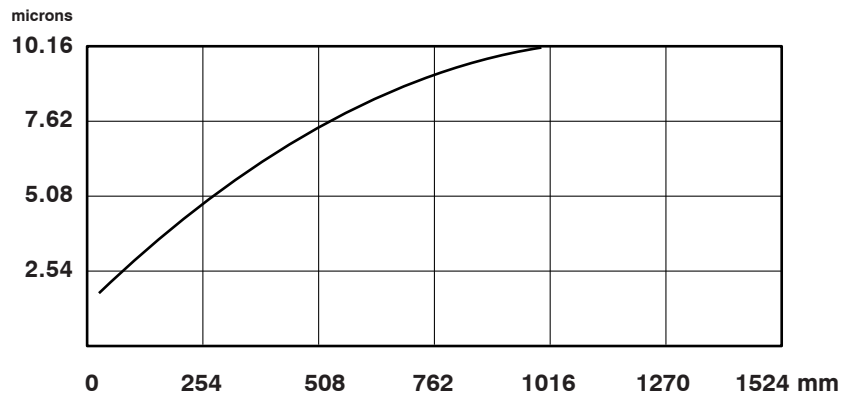
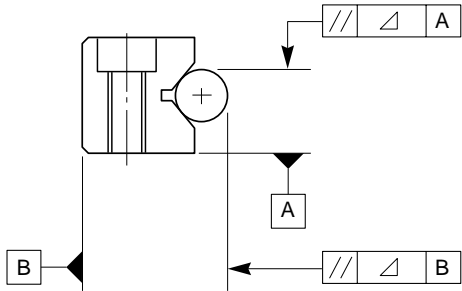

Maximum deviation from parallelism between the vee groove face and datum faces of each way bar is shown in the graph. Actual accuracy achieved depends on proper installation.

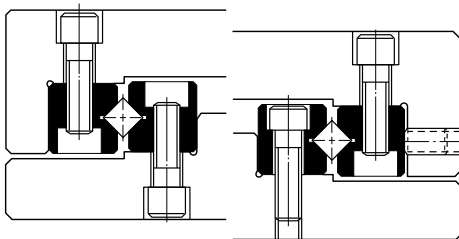

Mounting holes in the way bars are threaded, and also counterbored to alternatively permit using the next smaller size screw with threaded mounting holes in the user's components.

Ordering

Order standard bearing sets from table by model number according to load and travel required.

Each set consists of two complete bearings (4 way bars, 2 roller cages, and end stops). Delivery stock to 6 weeks.

Crossed Roller Rail Sets

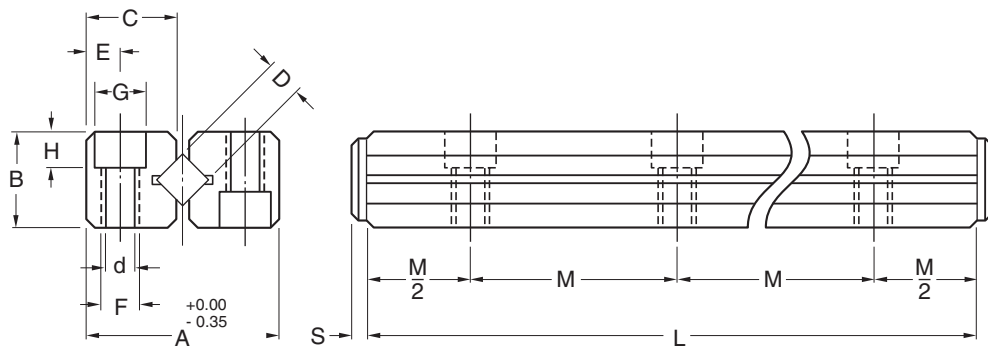

Length, Travel, and Load Selection

moment load ratings + load / life formulas. pg.95

MODEL	NO. OF ROLLERS IN EACH RETAINER	LENGTH L	TRAVEL T	NO. HOLES	RAIL SET LOAD CAPACITY kg	MODEL	NO. OF ROLLERS IN EACH RETAINER	LENGTH L	TRAVEL T	NO. HOLES	RAIL SET LOAD CAPACITY kg
NB-1020	5	20	12	2	20	NB-3225	31	225	135	9	310
NB-1030	7	30	20	3	28	NB-3250	35	250	145	10	350
NB-1040	10	40	27	4	40	NB-3275	38	275	165	11	380
NB-1050	13	50	32	5	52	NB-3300	42	300	175	12	419
NB-1060	16	60	37	6	64	NB-3325	45	325	195	13	449
NB-1070	19	70	42	7	76	NB-3350	49	350	205	14	489
NB-1080	21	80	50	8	84						
NB-2030	5	30	18	2	30	NB-4080	7	80	58	2	140
NB-2045	8	45	24	3	48	NB-4120	11	120	82	3	220
NB-2060	11	60	30	4	66	NB-4160	15	160	105	4	300
NB-2075	13	75	44	5	78	NB-4200	19	200	130	5	380
NB-2090	16	90	50	6	96	NB-4240	23	240	150	6	459
NB-2105	18	105	64	7	108	NB-4280	27	280	175	7	539
NB-2120	21	120	70	8	126	NB-4320	31	320	200	8	619
NB-2135	23	135	84	9	138	NB-4360	35	360	225	9	699
NB-2150	26	150	90	10	156	NB-4400	39	400	250	10	779
NB-2165	29	165	95	11	173	NB-4440	43	440	270	11	859
NB-2180	32	180	100	12	192	NB-4480	47	480	295	12	939
NB-3050	7	50	28	2	70	NB-6100	8	100	55	2	320
NB-3075	10	75	48	3	100	NB-6150	12	150	85	3	479
NB-3100	14	100	58	4	140	NB-6200	16	200	120	4	639
NB-3125	17	125	78	5	170	NB-6250	20	250	150	5	799
NB-3150	21	150	88	6	210	NB-6300	24	300	185	6	959
NB-3175	24	175	105	7	240	NB-6350	28	350	215	7	1119
NB-3200	28	200	115	8	280	NB-6400	32	400	245	8	1278

Please specify (SS) for Stainless Steel

Dimensions in mm

SERIES	Profile Dimensions					Mounting Dimensions						
	A	B	C	D	S	M	E	F*	J**	d	G	H
NB-1	8.5	4.0	3.9	1.5	1.5	10	1.8	M2	M1	1.65	3.0	1.4
NB-2	12	6.0	5.5	2.0	2.0	15	2.5	M3	M2	2.54	4.4	2.0
NB-3	18	8.0	8.3	3.0	2.0	25	3.5	M4	M3	3.30	6.0	3.1
NB-4	22	11	10.2	4.0	2.0	40	4.5	M5	M4	4.3	8.0	4.2
NB-6	31	15	14.2	6.0	3.0	50	6.0	M6	M5	5.2	9.5	5.2

*Thread Size **Hole F clears cap screw for through mounting.

Dimensions in mm

Modifying Length of Travel

For a given length of bearing way, since there is no slip at any load, both length of travel and load capacity depend on the number of rollers and their pitch. The number of rollers supplied with each standard bearing set provides a travel distance of approximately 60% of the way length (see page 48). In some cases (e.g., when mounting space is restricted)

it may be practical to increase travel at the expense of load capacity by removing one or more rollers instead of selecting a longer bearing. Since travel extends symmetrically around the mean position, the travel increase is twice the pitch for each roller removed. Similarly, the load capacity for the set (page 48) is reduced by twice the load capacity per roller.

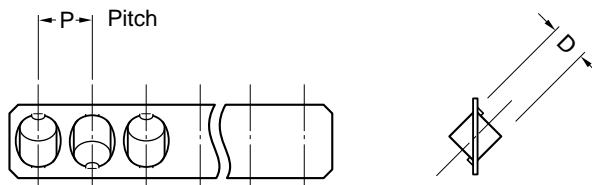

ROLLER SIZE	ROLLER DIAMETER (D) mm	ROLLER DISTANCE (P) mm	INCREASE OF TRAVEL FOR EACH ROLLER CUT-OFF mm	ROLLER LOAD CARRYING CAP. PER ROLLER kg
NB-1	1.5	2.5	5	4
NB-2	2.0	4	8	6
NB-3	3	5	10	10
NB-4	4	7	14	20
NB-6	6	8.5	17	40

Dimensions in mm

Anti-Creep Crossed Roller Rail Sets

6 Reasons to choose Del-Tron[®] Anti-Creep Crossed Roller Rail Sets

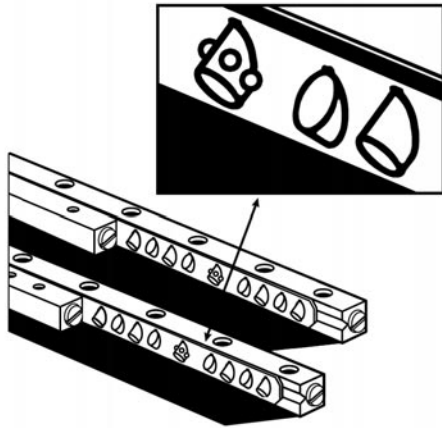

1. Designed for vertical applications and cantilevered loads.
2. Rugged- Hardened steel V-grooved rails and rollers withstand heavy loads.
3. Versatile- May be integrated into your own design.
4. High Accuracy- Parallelism of 0.002mm over 100mm
5. Easy to use- Standard threaded and counterbored mounting holes allow access from either side.
6. Interchangeable- Form, fit and functional replacement for other manufacturer's Rail sets.

Del-Tron[®] Anti-Creep Crossed Roller Rail Sets

The Anti-Creep crossed roller rail system is based on a new concept to prevent roller cage slippage during operation. This system allows you to mount the rail set in any orientation while maintaining direct roller contact to the rail surface eliminating roller cage creep. This system is ideal for vertical applications and where high acceleration and deceleration forces are present.

Construction

Each bearing set contains four V-grooved Rails, eight end screws, and two Anti-Creep crossed roller retainers. The Anti-Creep crossed roller retainers utilize a studded roller and detented rail to prevent the migration of the retainer due to vertical and cantilevered load applications.

Application

Bearings are normally supplied and installed in sets of two to form an assembly that can support their rated load in any direction or orientation, and can be preloaded to eliminate side play.

Mounting and banking surfaces must be smooth and flat, and accurately parallel, coplanar, or perpendicular respectively to achieve maximum accuracy. Preload forces must be evenly distributed. Dirt and dust must be excluded. Lubrication required depends on the application, ranging from light grease or oil at the time of installation for low speeds 1270mm/min. and occasional movement to continuous oil bath or mist at 30000 mm/min.

RATINGS AND SPECIFICATIONS

Load ratings in the tables are dynamic ratings for each set. Ratings are based on theoretical data, proper installation, appropriate lubrication, and a predicted life of 254 million mm. Ratings are suggested only, based on standard and typical industry practice, and cannot be guaranteed. Life can be increased approximately 10 times by operating a given bearing at 1/2 its rated load, other factors being constant. Temperature of bearings must not exceed 82°C, even for short periods, since this will reduce hardness and result in significantly reduced load capacity and working life.

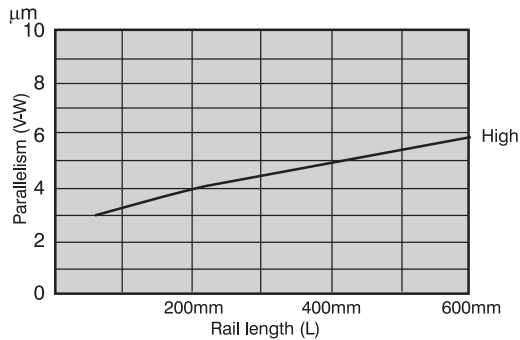
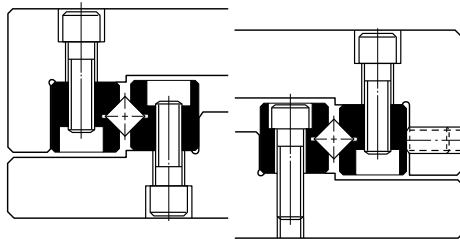

Fig. 1



ACCURACY

The accuracy of a slide is measured along its entire length, as illustrated in Fig 2, and expressed in terms of parallelism (Fig 1.) Actual accuracy achieved depends on proper installation.

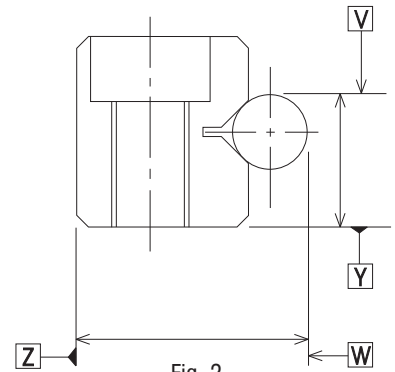

Fig. 2

Mounting holes in the way bars are threaded, and also counterbored to alternatively permit using the next smaller size screw with threaded mounting holes in the user's components.

INSTALLATION PROCEDURE

Note:

- * Provide external mechanical stoppers.
- * Set the movement to be less than the specified stroke.

- (1) Remove burrs, scratches, and dust from the rail mounting surface of the table and bed, and be careful to prevent contamination during assembly.
- (2) Apply low-viscosity oil to the contact surfaces, and align the table and the bed. (Figure 10a)
- (3) Set the reference surface shown in Figure 4 onto the mounting surface with the rails assembled. Set the table in the center position, and tighten the adjustment screws lightly so that almost no gap remains. (Figure 10b)
- (4) Keep the table in the center, tighten the rail mounting bolts lightly, loosen the end pieces of both end faces, and remove the fastening plate. Following this, firmly retighten the end pieces.
- (5) While maintaining the conditions of (4), gently move the assembly through its stroke being certain to check that the specified stroke length has been secured, and that there is no problem with the operation, or any other irregularity.
- (6) Move the table to the center and tighten only the adjustment screws on the R-retainer with the recommended tightening torque as shown in Table 3. (Figure 10c)
- (7) Gently move the table to one stroke end, and check that the table has surely come into contact with the external mechanical stopper. Following this, tighten the adjustment screws on the R-retainer in the same manner as (6). (Figure 10d)
- (8) Move the table to the opposite stroke end, and tighten in the same manner as (6). (Figure 10e)
- (9) Fasten the mounting bolts on rails 1, 2, and 3 by tightening with the recommended torque shown in Table 4. (Figure 10f)
- (10) Set the dial indicators to the center of the table and to the side (reference surface) of the table. (Figure 10g)
- (11) Perform the final preload adjustment. While moving the table back and forth, repeat steps (6) and (7) until the dial indicators show a minimum deviation.
- (12) Finally, securely fasten rail 4, which has been provisionally mounted, using the recommended torque. As with the adjustment screws, successively tighten the mounting bolts on the R-retainer while moving the table.

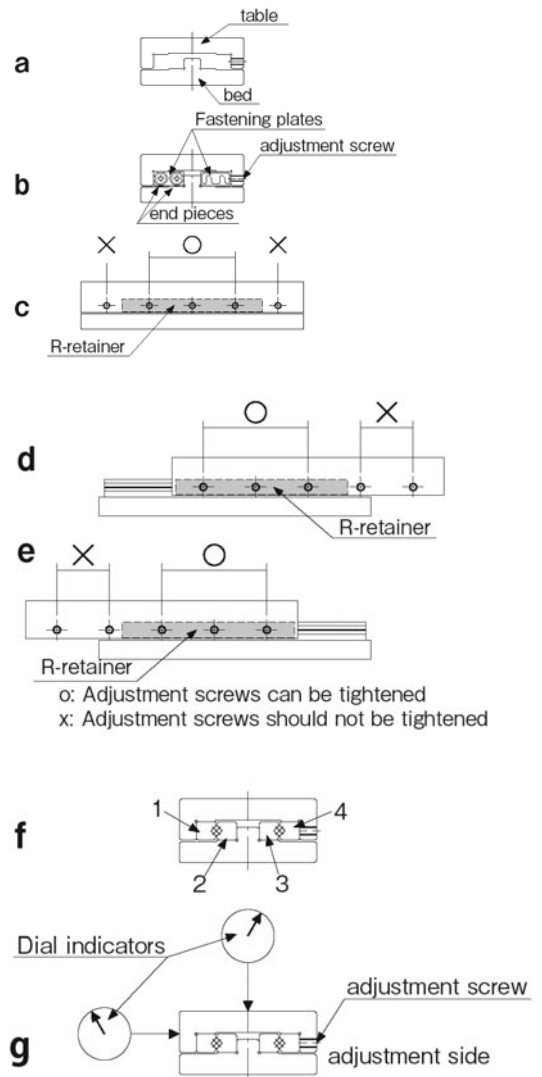



Anti-Creep Crossed Roller Rail Sets

Ordering

Order standard bearing sets from table by model number according to load and travel required

Each set consists of two complete bearings (4 rails, 2 roller cages, and end stops).

Delivery stock to 8 weeks.

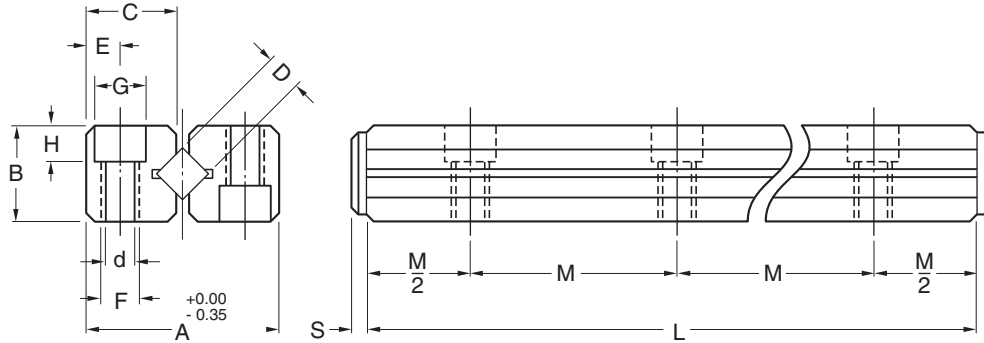

moment load ratings + load / life formulas. pg. 96

*Travel is 1/2 distance from center in either direction.											
MODEL	NO. OF ROLLERS IN EACH RETAINER	LENGTH L	TRAVEL* T	NO. HOLES	RAIL SET LOAD CAPACITY LB	MODEL	NO. OF ROLLERS IN EACH RETAINER	LENGTH L	TRAVEL* T	NO. HOLES	RAIL SET LOAD CAPACITY LB
NB-2030-AC	5	30	18	2	30	NB-3225-AC	43	225	150	9	310
NB-2045-AC	9	45	25	3	48	NB-4080-AC	9	80	60	2	140
NB-2060-AC	15	60	30	4	66	NB-4120-AC	17	120	75	3	220
NB-2075-AC	19	75	40	5	78	NB-4160-AC	23	160	105	4	300
NB-2090-AC	23	90	50	6	96	NB-4200-AC	29	200	130	5	380
NB-2105-AC	27	105	65	7	108	NB-4240-AC	37	240	143	6	459
NB-2120-AC	33	120	70	8	126	NB-4280-AC	43	280	170	7	539
NB-2135-AC	39	135	80	9	138	NB-6100-AC	9	100	63	2	320
NB-2150-AC	41	150	90	10	156	NB-6150-AC	15	150	85	3	479
NB-2165-AC	47	165	95	11	173	NB-6200-AC	19	200	135	4	639
NB-2180-AC	51	180	100	12	192	NB-6250-AC	25	250	158	5	799
NB-3050-AC	9	50	25	2	70	NB-6300-AC	31	300	180	6	959
NB-3075-AC	13	75	48	3	100	NB-6350-AC	35	350	230	7	1119
NB-3100-AC	19	100	60	4	140	NB-6400-AC	39	400	275	8	1280
NB-3125-AC	23	125	83	5	170						
NB-3150-AC	29	150	90	6	210						
NB-3175-AC	35	175	103	7	240						
NB-3200-AC	41	200	113	8	280						

SERIES	Profile Dimensions					Mounting Dimensions						
	A	B	C	D	S	M	E	F*	J**	d	G	H
NB-2-AC	12	6.0	5.5	2.0	2.0	15	2.5	M3	M2	2.55	4.4	2.0
NB-3-AC	18	8.0	8.3	3.0	2.0	25	3.5	M4	M3	3.30	6.0	3.1
NB-4-AC	22	11	10.2	4.0	2.0	40	4.5	M5	M4	4.3	8.0	4.2
NB-6-AC	31	15	14.2	6.0	3.0	6.0	6.0	M6	M5	5.2	9.5	5.2

*Thread Size **Hole F clears cap screw for through mounting.

Crossed Roller Slide Tables (Aluminum)

6 Reasons to choose Del-Tron® Crossed Roller Slide Tables (Aluminum)

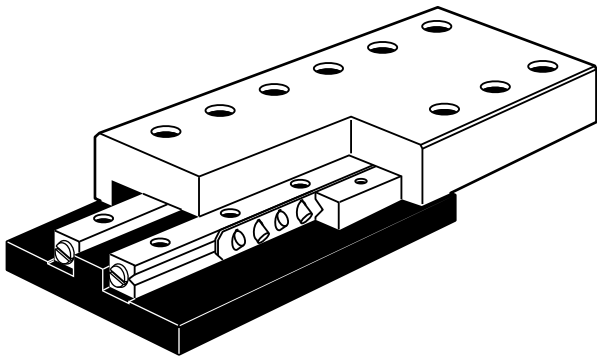

1. **High accuracy and load capacity.**
(Precision ground V grooved ways and rollers.)
2. **Withstands force in any direction.**
(Alternately crossed rollers 45° angle.)
3. **Easy installation.** (Metric threaded mounting holes in standard pattern.)
4. **Corrosion Resistant-Non Contaminating**
(Stainless steel models available.)
5. **Lightweight.** (Aluminum base and carriage.)
6. **Interchangeable** (with other manufacturer's slides.)

Del-Tron® Crossed Roller Slide Tables

Our Aluminum Series crossed roller slide tables offer low cost and lightweight aluminum body construction to support heavy loads with low friction and precision linear motion. Select from over 40 standard sizes for use in a wide range of applications - precision instruments, office and communications equipment, surface grinders, tool grinders, and assembly fixtures, as examples.

Factory assembled and ready to install, each positioning table consists of an aluminum base and an aluminum carriage, both precision milled, and a pair of hardened steel linear bearings. Counterbored clearance holes, in base, permit easy mounting. Threaded holes, closely spaced in carriage, permit attaching your components without additional machining. Factory preloaded bearings eliminate side play. Internal stops, in the form of projecting screw heads between the underside of the carriage and base, protect bearings from overtravel during handling.

Mount on flat surfaces to provide full support to the base. Loads stated, may be applied in any direction. Load values are calculated for weights evenly distributed on your positioning table. For full life of tables, we recommend careful calculation of moments and cantilevered loads.



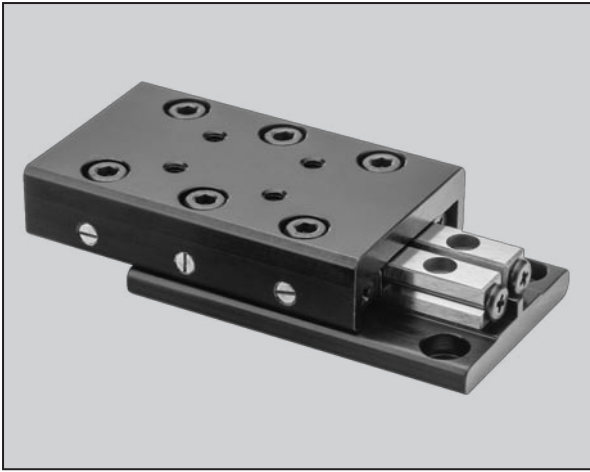

Crossed Roller Slide Tables (Aluminum)

Stainless Steel Models Available

For applications where particulate contamination caused by corrosion must be reduced, Del-Tron offers Aluminum crossed roller slide tables equipped with corrosion-resistant, stainless steel, crossed roller linear bearings.

TO ORDER:

Add SS to model number before "AM". For example:
NBT-4085SSAM

moment load ratings + load / life formulas. pg.96

MODEL	STAINLESS STEEL	TRAVEL T	LENGTH L	LOAD CAPACITY kgf	BASE MOUNTING HOLES (COUNTERBORED)			CARRIAGE MOUNTING HOLES (THREADED)	
					NO. HOLES	SPACING U W		NO. HOLES	SPACING M
NBT-1050AM	SS	25	50	43	4	40	—	4	1 x 15
NBT-1065AM	SS	38	65	51	4	55	—	6	2 x 15
NBT-1080AM	SS	50	80	66	8	70	40	8	3 x 15
NBT-1095AM	SS	64	95	73	8	85	55	10	4 x 15
NBT-1125AM	SS	75	125	89	8	115	85	14	6 x 15
NBT-2035A-18M	SS	18	35	30	4	25	—	2	—
NBT-2050AM	SS	25	50	44	4	40	—	4	1 x 15
NBT-2050A-30M	SS	30	50	44	4	40	—	4	1 x 15
NBT-2065AM	SS	38	65	52	4	55	—	6	2 x 15
NBT-2065A-40M	SS	40	65	52	4	55	—	6	2 x 15
NBT-2080A-50M	SS	50	80	66	8	70	40	8	3 x 15
NBT-2080AM	SS	50	80	66	8	70	40	8	3 x 15
NBT-2095A-60M	SS	60	95	74	8	85	55	10	4 x 15
NBT-2095AM	SS	64	95	74	8	85	55	10	4 x 15
NBT-2110A-70M	SS	70	110	85	8	100	70	12	5 x 15
NBT-2125AM	SS	75	125	90	8	115	85	14	6 x 15
NBT-2125A-80M	SS	80	125	90	8	115	85	14	6 x 15
NBT-2155A-100M	SS	100	155	144	8	145	115	18	8 x 15
NBT-2185A-120M	SS	120	185	174	8	175	145	22	10 x 15
NBT-3055AM	SS	25	55	88	4	35	—	2	—
NBT-3055A-30M	SS	30	55	88	4	35	—	2	—
NBT-3080A-45M	SS	45	80	100	4	60	—	4	1 x 25
NBT-3105AM	SS	50	105	154	4	85	—	6	2 x 25
NBT-3105A-60M	SS	60	105	154	4	85	—	6	2 x 25
NBT-3130A-75M	SS	75	130	170	4	110	—	8	3 x 25
NBT-3155AM	SS	75	155	217	4	135	—	10	4 x 25
NBT-3155A-90M	SS	90	155	217	4	135	—	10	4 x 25
NBT-3180AM	SS	100	180	248	4	160	—	12	5 x 25
NBT-3180A-105M	SS	105	180	248	4	160	—	12	5 x 25
NBT-3205AM	SS	125	205	262	8	185	85	14	6 x 25
NBT-3205A-130M	SS	130	205	262	8	185	85	14	6 x 25
NBT-3230A-155M	SS	155	230	290	8	210	109	16	7 x 25
NBT-3255A-180M	SS	180	255	310	8	235	135	18	8 x 25
NBT-3280A-205M	SS	205	280	340	8	260	160	20	9 x 25
NBT-3305A-230M	SS	230	305	360	8	285	185	22	10 x 25
NBT-4085AM	SS	50	85	196	4	65	—	2	—
NBT-4125AM	SS	75	125	273	4	105	—	4	1 x 40
NBT-4165AM	SS	100	165	329	4	145	—	6	2 x 40
NBT-4205AM	SS	125	205	395	4	185	—	8	3 x 40
NBT-4245AM	SS	150	245	462	4	225	—	10	4 x 40
NBT-6110AM	SS	75	110	280	4	90	—	2	—
NBT-6160AM	SS	100	160	483	4	140	—	4	1 x 50
NBT-6260AM	SS	150	260	728	4	240	—	8	3 x 50
NBT-6360AM	SS	225	360	924	8	340	140	12	5 x 50

Dimensions in mm

SERIES	Mounting Dimensions							
	CARRIAGE				BASE			
	SPACING		THREAD	DEPTH	SPACING		COUNTERBORE	
	N	P	J	K	R	S	D	d
NBT-1000AM	17.5	10	M3	4.5	5	22	6.1	3.5
NBT-2000AM	17.5	15	M4	8	5	30	8.1	4.6
NBT-3000AM	27.5	25	M5	10.5	10	40	10.1	5.8
NBT-4000AM	42.5	40	M5	13	10	55	10.1	5.8
NBT-6000AM	55	50	M6	16	10	60	11.0	7.1

Dimensions in mm

Specifications:

Straight Line Accuracy
0.0025mm/25mm of travel

Finish
Carriage: Black anodize,
Base: Black anodize

Positional Repeatability
0.0025mm

Coefficient of Friction
0.003 typical

Construction
Aluminum carriage and base, hardened
steel crossed roller rail sets.

Ordering
Order standard positioning tables from
table by model number according to
load and travel required.

Delivery stock to 6 weeks.

CARRIAGE MOUNTING DIMENSIONS

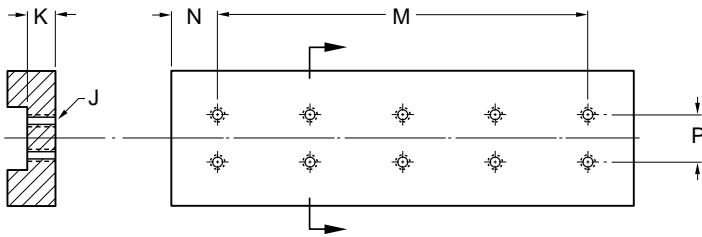

BASE MOUNTING DIMENSIONS

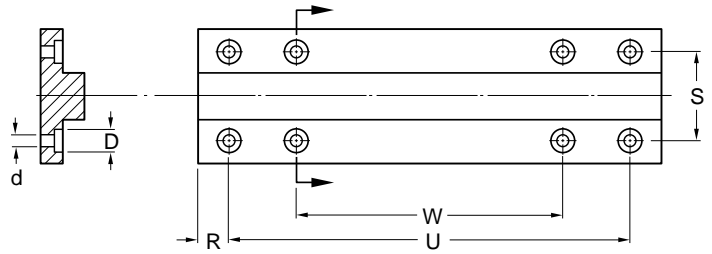

SERIES	Profile Dimensions		
	HEIGHT A ±0.13	WIDTH B ±0.25	BASE THICKNESS C
NBT-1000AM	15	30	4.1
NBT-2000AM	21	40	6.5
NBT-3000AM	28	60	9
NBT-4000AM	35	80	10.5
NBT-6000AM	45	100	13

Dimensions in mm

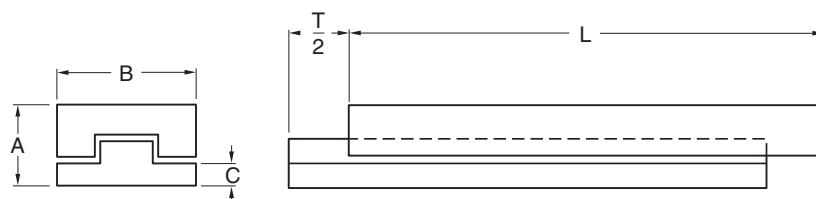

Anti-Creep Crossed Roller Slide Tables (Aluminum)

6 Reasons to choose Del-Tron® Anti-Creep Crossed Roller Slide Tables (Aluminum)

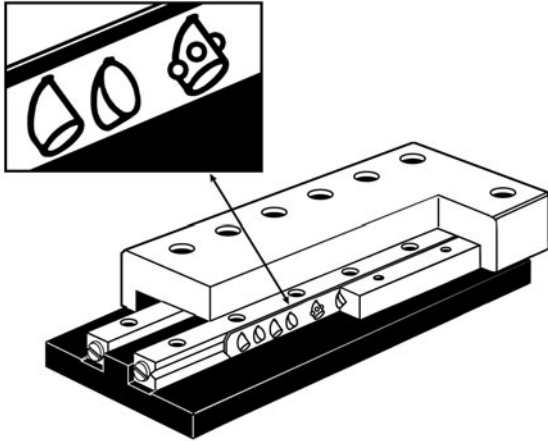

1. **Anti-Creep Crossed Roller Technology.** Ideal for vertical and cantilevered load applications.
2. **High accuracy and load capacity.** Precision V grooved rails and rollers.
3. **Lightweight aluminum carriage and base design.**
4. **Withstands force in any direction.** Alternately crossed roller cage design.
5. **Easy installation.** Threaded and counterbored mounting holes in standard pattern.
6. **Interchangeable with other manufacturer's slides.**

Del-Tron® Anti-Creep Crossed Roller Slide Tables

The Anti-Creep crossed roller slide tables utilize our Anti-Creep crossed roller rail systems to prevent roller cage slippage during operation. This system allows you to mount the table in any orientation while maintaining direct roller contact to the rail surface eliminating roller cage creep. These tables are ideal for vertical applications and where high acceleration and deceleration forces are present.

Factory assembled and ready to install, each positioning table consists of an aluminum base and an aluminum carriage, both precision milled, and a pair of hardened steel linear bearings. Counterbored clearance holes, in base, permit easy mounting. Threaded holes, closely spaced in carriage, permit attaching your components without additional machining. Factory preloaded bearings eliminate side play. Internal stops, in the form of projecting screw heads between the underside of the carriage and base, protect bearings from over travel during handling.

Mount on flat surfaces to provide full support to the base. Loads stated, may be applied in any direction. Load values are calculated for weights evenly distributed on your positioning table. For full life of tables, we recommend careful calculation of moments and cantilevered loads.



Anti-Creep Crossed Roller Slide Tables (Aluminum)

Stainless Steel Models Available

For applications where particulate contamination caused by corrosion must be reduced, Del-Tron offers Aluminum crossed roller positioning tables equipped with corrosion-resistant, stainless steel, crossed roller linear bearings.

TO ORDER:

Add SS to model number before "AM". For example: NBT-4085SSAM-AC

moment load ratings + load / life formulas. pg. 97

MODEL	TRAVEL* T	LENGTH L	LOAD CAPACITY LBF (kgf)	BASE MOUNTING HOLES (COUNTERBORED)			CARRIAGE MOUNTING HOLES (THREADED)	
				NO. HOLES	SPACING		NO. HOLES	SPACING M
					U	W		
NBT-1050AM-AC	25	50	43	4	40	—	4	15
NBT-1065AM-AC	30	65	51	4	55	—	6	15
NBT-1080AM-AC	40	80	65	8	70	40	8	15
NBT-1095AM-AC	50	95	73	8	85	55	10	15
NBT-1125AM-AC	70	125	89	8	115	85	14	15
NBT-2035AM-18-AC	18	35	30	4	25	—	2	15
NBT-2050AM-AC	25	50	44	4	40	—	4	15
NBT-2065AM-AC	30	65	52	4	55	—	6	15
NBT-2080AM-AC	40	80	66	8	70	—	8	15
NBT-2095AM-AC	50	95	74	8	85	55	10	15
NBT-2110AM-70-AC	65	110	85	8	100	70	12	15
NBT-2125AM-AC	70	125	90	8	115	85	14	15
NBT-2155AM-100-AC	90	155	144	8	145	115	18	15
NBT-2185AM-120-AC	100	185	174	8	175	145	22	15
NBT-3055AM-AC	25	55	88	4	35	—	2	25
NBT-3080AM-45-AC	48	80	100	4	60	—	4	25
NBT-3105AM-AC	60	105	154	4	85	—	6	25
NBT-3130AM-75-AC	83	130	170	4	110	—	8	25
NBT-3155AM-AC	90	155	217	4	135	—	10	25
NBT-3180AM-AC	103	180	248	4	160	—	12	25
NBT-3205AM-AC	113	205	262	8	185	85	14	25
NBT-3230AM-155-AC	150	230	290	8	210	110	16	25
NBT-4085AM-AC	60	85	196	4	65	—	2	40
NBT-4125AM-AC	75	125	273	4	105	—	4	40
NBT-4165AM-AC	105	165	329	4	145	—	6	40
NBT-4205AM-AC	130	205	395	4	185	—	8	40
NBT-4245AM-AC	143	245	462	4	225	—	10	40
NBT-6110AM-AC	63	110	280	4	90	—	2	50
NBT-6160AM-AC	85	160	483	4	140	—	4	50
NBT-6260AM-AC	158	260	728	4	240	—	8	50
NBT-6360AM-AC	230	360	924	8	340	140	12	50

SERIES	Mounting Dimensions								
	CARRIAGE				BASE				
	SPACING N	P	THREAD J	DEPTH K	SPACING R	S	COUNTERBORE D d h		
NBT-1000AM-AC	17.5	10	M-3	4.5	5	22	5	3.1	3.2
NBT-2000AM-AC	17.5	15	M-4	8	5	30	6.1	3.7	3.7
NBT-3000AM-AC	27.5	25	M-5	10.5	10	40	8.3	5	5.2
NBT-4000AM-AC	42.5	40	M-5	13	10	55	8.3	5	5.2
NBT-6000AM-AC	55	50	M-6	16	10	60	10.3	6.7	8.0

Dimensions in mm

Specifications:

Straight Line Accuracy
0.0025mm/25mm of travel

Positional Repeatability
0.0025mm

Coefficient of Friction
0.003 typical

Construction
Aluminum carriage and base,
hardened steel crossed roller rail
sets.

Finish
Carriage: Black anodize, Base:
Black anodize

Ordering
Order standard slide tables from
table by model number according to
load and travel required.

Delivery stock to 6 weeks.

CARRIAGE MOUNTING DIMENSIONS

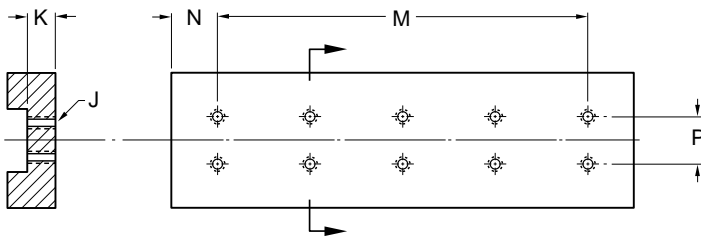

BASE MOUNTING DIMENSIONS

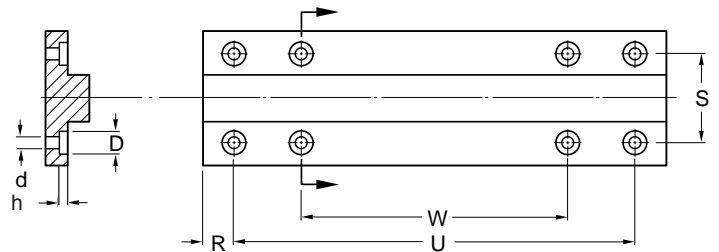

SERIES	Profile Dimensions		
	HEIGHT A ±0.13	WIDTH B ±0.25	BASE THICKNESS C
NBT-1000AM-AC	15	30	4.1
NBT-2000AM-AC	21	40	6.5
NBT-3000AM-AC	28	60	9
NBT-4000AM-AC	35	80	10.5
NBT-6000AM-AC	45	100	13

Dimensions in mm

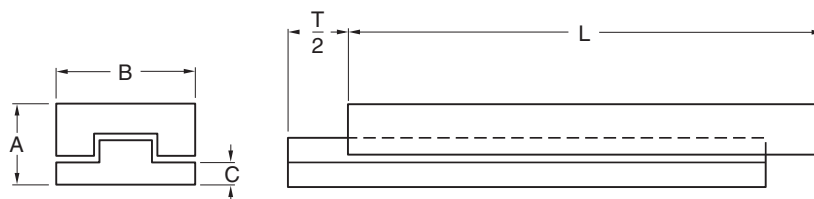

Crossed Roller Slide Tables (Steel)

6 Reasons to choose Del-Tron® Crossed Roller Slide Tables (Steel)

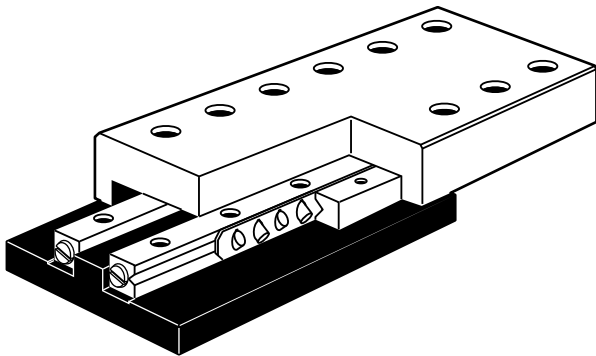

1. **High Accuracy** - .002mm parallelism.
2. **High Load Capacity** - Crossed roller way construction handles loads up to 1200 kg.
3. **Interchangeable** with other manufacturer's tables.
4. **Low Friction** - 0.003 coefficient of friction for smooth operation.
5. **Standard Mounting** - Holes provided.
6. **Backlash Free** - Factory preloaded for minimum axial play.

Del-Tron® Crossed Roller Slide Tables

Crossed Roller Slide Tables are factory assembled, and ready to install. They use Del-Tron crossed roller bearings to provide very precise linear motion with low friction and high support stiffness for the load. A selection of more than 40 standard sizes is available for applications including precision instruments, office and communications equipment, surface grinders, tool grinders, assembly fixtures, and anywhere precise linear positioning is required.

Construction

Each positioning table consists of a one piece base, a one piece carriage, and a pair of linear bearings. The bearings are factory preloaded to eliminate side play.

Counterbored clearance holes in the base permit easy mounting in your structure. Threaded holes in the carriage are closely spaced to permit attaching your components without additional machining in most cases.

Standard material for base and carriage is cold rolled steel, with black oxide finish.

Application

Mount on a flat surface to provide full support to the base.

Although it is seldom needed, the carriage surface can be machined or additional mounting holes can be added if the following precautions are observed:

1. Do not disassemble the table since reassembly and readjustment of the preloading require special procedures.
2. Protect the ways against entry of chips and debris.
3. Drill only blind holes through the carriage to avoid depositing chips inside the unit.
4. Avoid intersection with internal mounting or preloading screws.
5. Avoid clamping forces in excess of the rated load capacity.

Internal stops, in the form of projecting screw heads between the under side of the carriage and the base, are intended only to protect the bearings from overtravel during handling. Provide separate stops appropriate for your load if needed.

The ends of the carriage contain tapped holes that permit easy attachment of way covers, bellows, or other shields to exclude dust and keep the ways clean.



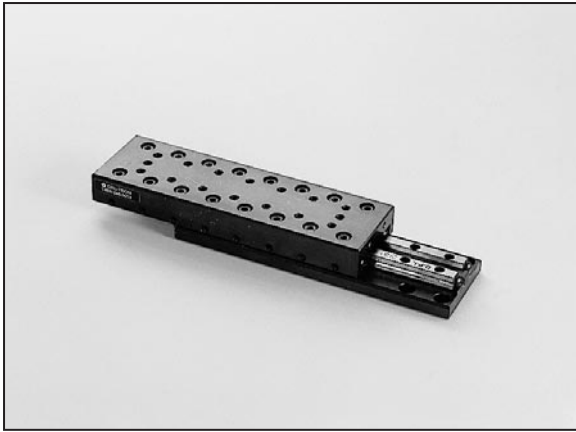

Crossed Roller Slide Tables (Steel)

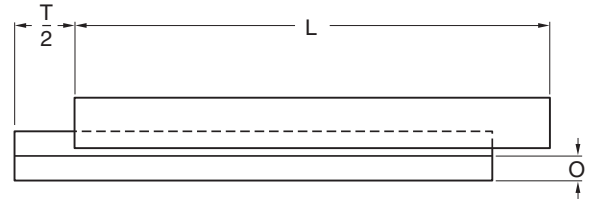

moment load ratings + load / life formulas. pg.97

Length, Travel and Load Selection

MODEL	TRAVEL T	LENGTH L	LOAD CAPACITY kgf	NO. HOLES	BASE MOUNTING HOLES (COUNTERBORED) SPACING					CARRIAGE MOUNTING HOLES (THREADED)	
					U	V	W	X	Y	NO. HOLES	SPACING M
NBT-1025	12	25	12	4	18	—	—	—	—	2	—
NBT-1035	18	35	16	4	28	—	—	—	—	4	1 × 10
NBT-1045	25	45	20	4	38	—	—	—	—	6	2 × 10
NBT-1055	32	55	26	8	48	—	28	—	—	8	3 × 10
NBT-1065	40	65	32	8	58	—	38	—	—	10	4 × 10
NBT-1075	45	75	36	8	68	—	48	—	—	12	5 × 10
NBT-1085	50	85	40	8	78	—	58	—	—	14	6 × 10
NBT-2035	18	35	40	4	25	—	—	—	—	2	—
NBT-2050	30	50	63	4	40	—	—	—	—	4	1 × 15
NBT-2065	40	65	75	4	55	—	—	—	—	6	2 × 15
NBT-2080	50	80	95	8	70	—	40	—	—	8	3 × 15
NBT-2095	60	95	105	8	85	—	55	—	—	10	4 × 15
NBT-2110	70	110	120	8	100	—	70	—	—	12	5 × 15
NBT-2125	80	125	130	8	115	—	85	—	—	14	6 × 15
NBT-2140	90	140	145	12	130	—	100	—	70	16	7 × 15
NBT-2155	100	155	155	12	145	—	115	—	85	18	8 × 15
NBT-2170	110	170	170	12	160	—	130	—	100	20	9 × 15
NBT-2185	120	185	180	16	175	—	145	—	115	22	10 × 15
NBT-3055	30	55	126	4	35	—	—	—	—	2	—
NBT-3080	45	80	184	4	60	—	—	—	—	4	1 × 25
NBT-3105	60	105	220	4	85	—	—	—	—	6	2 × 25
NBT-3130	75	130	275	4	110	—	—	—	—	8	3 × 25
NBT-3155	90	155	310	6	135	85	—	—	—	10	4 × 25
NBT-3180	105	180	355	6	159	110	—	—	—	12	5 × 25
NBT-3205	130	205	375	10	185	135	85	—	—	14	6 × 25
NBT-3230	155	230	420	10	210	160	110	—	—	16	7 × 25
NBT-3255	180	255	450	10	235	185	135	—	—	18	8 × 25
NBT-3280	205	280	490	12	260	210	160	110	—	20	9 × 25
NBT-3305	230	305	520	12	285	235	185	135	—	22	10 × 25
NBT-4085	50	85	280	4	65	—	—	—	—	2	—
NBT-4125	75	125	390	4	105	—	—	—	—	4	1 × 40
NBT-4165	105	165	470	4	145	—	—	—	—	6	2 × 40
NBT-4205	130	205	565	6	185	105	—	—	—	8	3 × 40
NBT-4245	155	245	660	6	225	145	—	—	—	10	4 × 40
NBT-4285	185	285	745	10	265	185	105	—	—	12	5 × 40
NBT-4325	210	325	830	10	305	225	145	—	—	14	6 × 40
NBT-6110	60	110	400	4	90	—	—	—	—	2	—
NBT-6160	95	160	690	4	140	—	—	—	—	4	1 × 50
NBT-6210	130	210	870	6	190	90	—	—	—	6	2 × 50
NBT-6260	165	260	1040	6	240	140	—	—	—	8	3 × 50
NBT-6310	200	310	1200	6	290	190	—	—	—	10	4 × 50

Dimensions in mm

Crossed Roller Slide Tables (Steel)

Load Ratings

See "Ratings and Specifications" page 54

The load capacities stated in the tables may be applied in any direction, and are assumed to be centered and evenly distributed over the table. Calculate moments and cantilevered loads carefully since inadvertent overloading will reduce service life.

Ordering

Order standard positioning tables from table by model number according to load and travel required.

Delivery stock to 6 weeks.

SERIES	MOUNTING DIMENSIONS						BASE	
	CARRIAGE		THREAD	DEPTH	SPACING		D	C'BORE d
	N	P			R	S		
NBT-1000	12.5	10	M2	7	3.5	22	4.5	2.5
NBT-2000	17.5	15	M3	8	5	30	6.5	3.5
NBT-3000	27.5	25	M4	10.5	10	40	8.0	4.5
NBT-4000	42.5	40	M5	13	10	55	10.0	5.5
NBT-6000	55	50	M6	16	10	60	11.5	7

Dimensions in mm

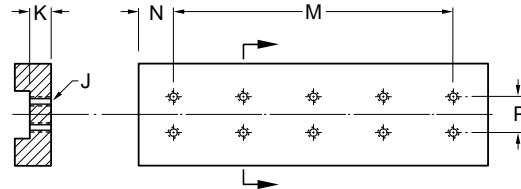

CARRIAGE MOUNTING DIMENSIONS

Accuracy

Top and bottom mounting surfaces and carriage side surfaces are ground flat and parallel to the line of motion. Accuracy of movement (V) is measured as a deflection over the center line of the carriage as shown. Accuracies, measured without load, depend primarily on overall length as listed.

Deflections (H), measured at either side of the carriage under the same conditions.

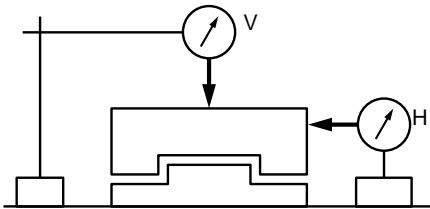

MODEL	Deflection		MODEL	Deflection		MODEL	Deflection	
	V	H		V	H		V	H
NBT 1025	2	4	NBT 2140	3	6	NBT 3305	3	7
NBT 1035	2	4	NBT 2155	3	6	NBT 4085	2	5
NBT 1045	2	4	NBT 2170	3	7	NBT 4125	3	6
NBT 1055	2	5	NBT 2185	3	7	NBT 4165	3	7
NBT 1065	2	5	NBT 3055	2	5	NBT 4205	3	7
NBT 1075	2	5	NBT 3080	2	5	NBT 4245	3	7
NBT 1085	2	5	NBT 3105	3	6	NBT 4285	3	7
NBT 2035	2	4	NBT 3130	3	6	NBT 4325	4	8
NBT 2050	2	4	NBT 3155	3	6	NBT 6110	3	6
NBT 2065	2	5	NBT 3180	3	7	NBT 6160	3	6
NBT 2080	2	5	NBT 3205	3	7	NBT 6210	3	7
NBT 2095	2	5	NBT 3230	3	7	NBT 6260	3	7
NBT 2110	3	6	NBT 3255	3	7	NBT 6310	3	7
NBT 2125	3	6	NBT 3280	3	7			

Dimensions in μm

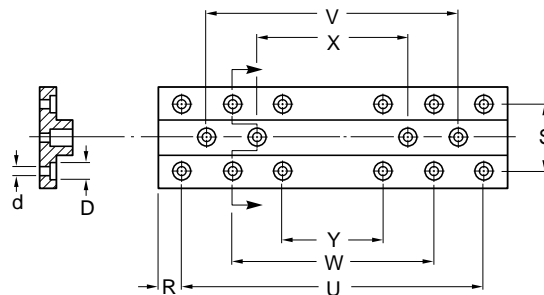

BASE MOUNTING DIMENSIONS

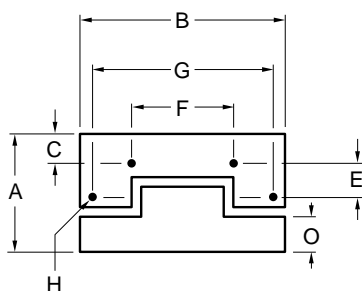

* Series NBT-1000 Tables use series NB-1 bearings etc.

SERIES *	PROFILE DIMENSIONS							
	HEIGHT A ± 0.1	WIDTH B** ± 0.1	FLANGE HEIGHT O	DUST COVER ATTACHMENT HOLES				THREAD
				C	E	F	G	
NBT-1000	17	30	5.5	2.5	—	12	—	M2
NBT-2000	21	40	6.5	3.4	—	16	—	M2
NBT-3000	28	60	9	5.5	—	40	—	M3
NBT-4000	35	80	10.5	6.5	—	55	—	M3
NBT-6000	45	100	13	8	15	60	92	M4

Dimensions in mm

** Except Series NBT-1000 and NBT-2000 $+0.2\text{mm}$
 -0.4mm

Recirculating Ball Slide Guides (BSGS)

6 Reasons to choose Del-Tron® Recirculating Ball Slide Guides

(BSGS)

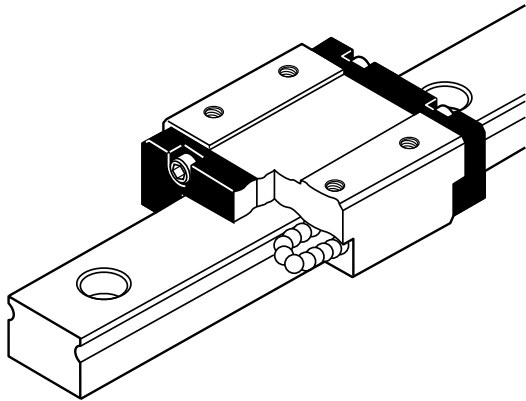

1. Smooth and stable operation.
2. Compact, lightweight and low price.
3. High load capacity due to R-shaped groove.
4. Four-point contact to carry load and moment in all directions.
5. 400 Series Stainless steel type.
6. Extra wide type available.

Del-Tron® Recirculating Ball Slide Guides (BSGS)

The BSGS type consists of a block and a guide rail, both having two R-shape raceway grooves machined by precision grinding. The block consists of a main body having raceway grooves and a resin return cap ensuring smooth circulation of balls. These precision steel balls roll in the respective raceway groove with contact at four points.

- Smooth and Stable operation. Since precision steel balls are used as rolling elements, the rolling resistance is extremely small, ensuring smooth and stable operation.
- Compact, lightweight, and low price. The block is a simple structure, so the slide guide is compact and inexpensive. Its compactness and light weight also make this product optimum for linear operation at high speed.
- High load capacity utilizing the R-shaped groove. The raceway surface over which the balls roll is an R-shaped groove, offering a large contact area. Therefore, the product features a large load capacity and a long effective life.
- Four-point contact to carry load and moment in all directions. The Gothic arch groove, where the balls contact the raceway surface at four points, enables the load and moment to be carried in all directions.
- Stainless steel type (BSGS) is available. The BSGS type uses stainless steel for the block and guide rail, thus having superior corrosion resistance.
- Extra wide type (BSGSW) is also available. With its increased number of rolling elements and increased width, this unit can replace the use of two linear guides. Stiffness in regard to moment load is increased, thus creating an effective compact linear motion mechanism.
- Slide guides are supplied with temporary ends stops. They are not to be used as positive stops.

Nomenclature

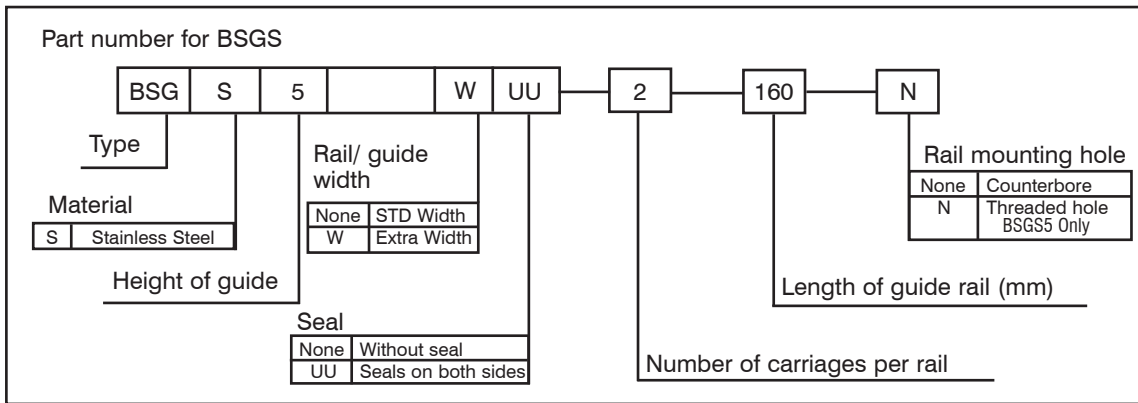

Unit: mm

Accuracy

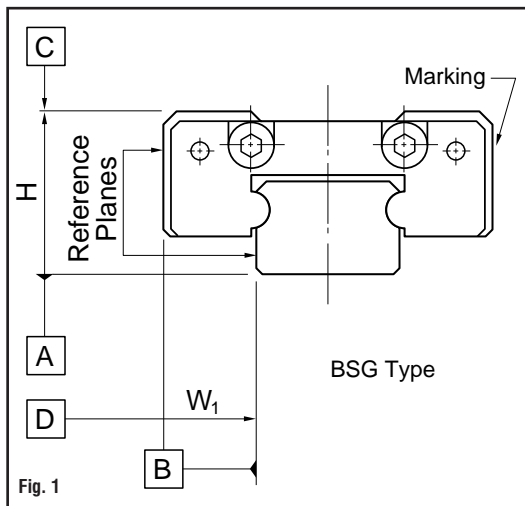

Height (H) tolerance	±0.041
Difference of heights (H) between paired ones	0.015
Width (W ₁) tolerance	±0.041
Difference of widths (W ₁) between paired ones	0.020
Running parallelism of C plane with respect to A plane	See Fig. 2
Running parallelism of D plane with respect to B plane	See Fig. 2

Travel Accuracy

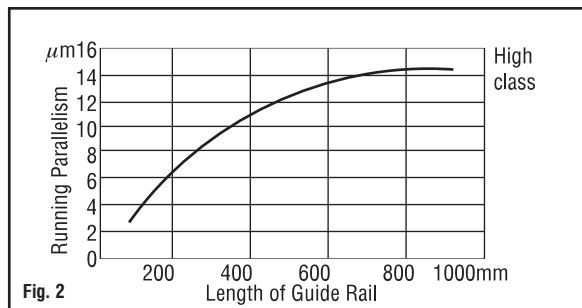

Unit: mm

Mounting Requirements

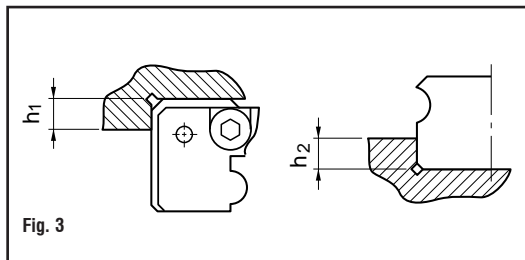

Nominal No.	Height of shoulder of carriage section h ₁	Height of shoulder of rail section h ₂
BSGS5	2	1
BSGS8	2.5	1
BSGS9W • BSGS10	3	1.5
BSGS12W	3	2.5
BSGS13	4	2
BSGS14W	4	2.5
BSGS16	5	3.5
BSGS16W	5	2.5
BSGS25	8.5	4

The corners of the reference planes should be finished with undercuts as shown in Figure 3. The recommended heights of the shoulders of the mounting planes are as shown in the table. To attain high accuracy, it is recommended to finish the mounting planes of the bed and table to an accuracy the same as or better than that of the guide rail and block.

Fixing Method

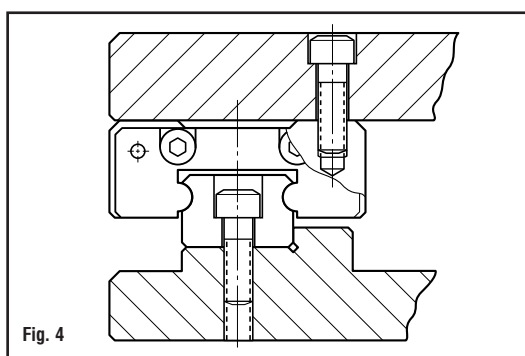

Recommended Tightening Torques: The recommended tightening torques for the mounting bolts (hex socket head bolts) are shown here.

Unit: N·m

Nominal Bolt Size	Tightening Torques
M2	0.4
M3	1.0
M4	2.5
M5	4.9

To install a BSGS Slide Guide (Fig. 4), confirm the reference planes as shown in Figure 1, then let the reference planes of the bed and table make close contact with the reference planes of the object and fix them. When using two guide rails, fix the reference side in a state in which it is closely contacted with the reference plane. Fix the adjustment side after adjusting the traveling state with either the guide rails or the block in a free state.

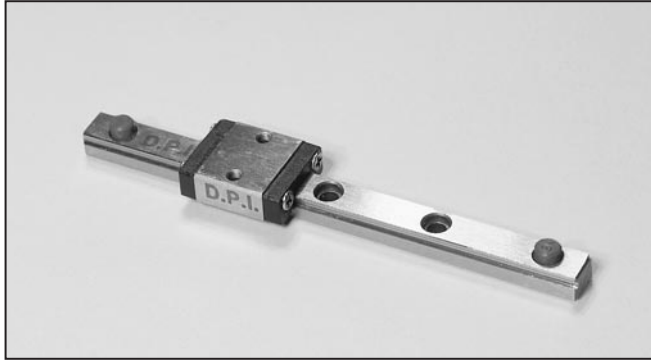

Ball Slide Guide BSGS (Stainless Steel)

Dimension - mm

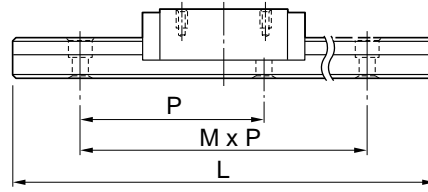

Maximum length is available for special order.

MODEL	GUIDE RAIL LENGTHS / [NUMBER OF HOLES]					MAX LENGTH					
	Lmm	[M]	Lmm	[M]	Lmm	[M]	P	STEEL	STAINLESS		
BSGS5 BSGS5UU	40	[2]	55	[3]	70	[4]	100	[6]	15	N/A	340
BSGS8 BSGS8UU	40	[2]	55	[3]	70	[4]	85	[5]	15	N/A	700
BSGS10 BSGS10UU	55	[2]	75	[3]	95	[4]	115	[5]	20	500	1000
BSGS13 BSGS13UU	120	[4]	170	[6]	220	[8]	270	[10]	25	500	1000
BSGS16 BSGS16UU	150	[3]	230	[5]	310	[7]	430	[10]	40	1900	1000
BSGS25 BSGS25UU	220	[3]	280	[4]	340	[5]	460	[7]	60	1900	1000

See page 84 for Carriage information.

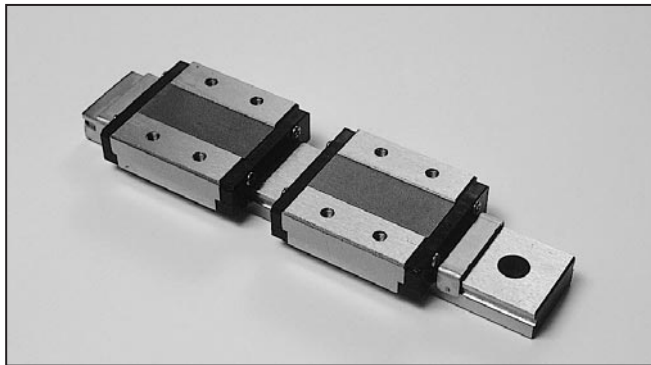

Ball Slide Guide Extra Wide BSGS-W (Stainless Steel)

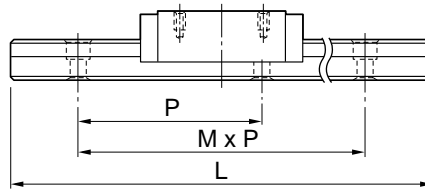

Maximum length is available for special order.

MODEL	GUIDE RAIL LENGTHS / [NUMBER OF HOLES]					MAX LENGTH					
	Lmm	[M]	Lmm	[M]	Lmm	[M]	P	STEEL	STAINLESS		
BSGS9W BSGS9WUU	80	[2]	110	[3]	140	[4]	170	[5]	30	N/A	700
BSGS12W BSGS12WUU	80	[2]	110	[3]	140	[4]	170	[5]	30	1000	1000
BSGS14W BSGS14WUU	110	[2]	150	[3]	190	[4]	230	[5]	40	1900	1000
BSGS16W BSGS16WUU	150	[3]	230	[5]	310	[7]	430	[10]	40	1900	1000

See page 85 for Carriage information.

Ball Slide Guide

BSGS

(Stainless Steel)

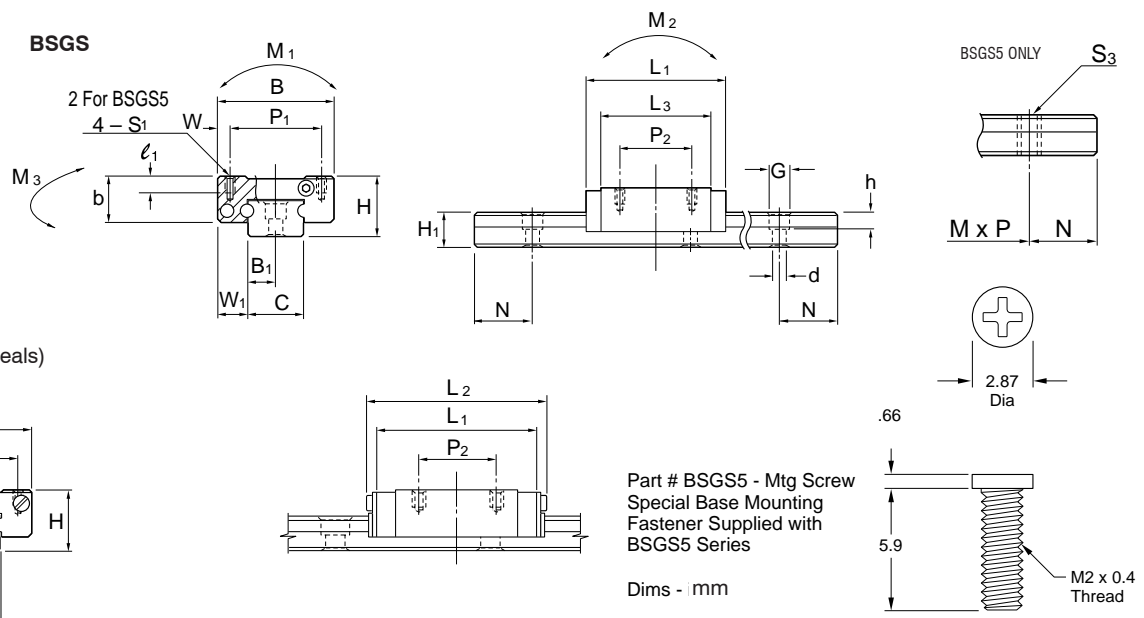

MODEL	DIMENSIONS OF CARRIAGE											BASIC LOAD RATING	
	H	B	L ₂	L ₁	W	P ₁	P ₂	S ₁	l ₁	L ₃	b	C kgf	Co kgf
STAINLESS STEEL													
BSGS5 BSGS5UU	6	12	17	15.6	2	8	—	M2	1.5	9.8	4.5	44	73
BSGS8 BSGS8UU	8	17	23.5	21.9	2.5	12	8	M2	2.5	15.1	6.5	110	170
BSGS10 BSGS10UU	10	20	30.5	28.1	2.5	15	10	M3	3	20.4	7.8	170	250
BSGS13 BSGS13UU	13	27	34	30	3.5	20	15	M3	3.5	23	10	220	320
BSGS16 BSGS16UU	16	32	42.5	38.5	3.5	25	20	M3	4	29.5	12	370	550
BSGS25 BSGS25UU	125	46	62	55.7	4	38	38	M4	6	45.7	17.5	701	1001

Dimensions in mm

MODEL	DIMENSIONS OF GUIDE RAIL							WEIGHT	
	H ₁	C	B ₁	W ₁	d x G x h	S3 N Type	N	Carriage kg	Guide Rail kg/m
STAINLESS STEEL									
BSGS5 BSGS5UU	4	5	2.5	3.5	2.4x 3.5 x 1	M2.6	5	.003	.43
BSGS8 BSGS8UU	4.7	7	3.5	5	2.4 x 4.2 x 2.3	—	5	0.01	0.19
BSGS10 BSGS10UU	5.5	9	4.5	5.5	3.5 x 6 x 3.5	—	7.5	0.02	0.31
BSGS13 BSGS13UU	7.2	12	6	7.5	3.5 x 6 x 4.5	—	10	0.04	0.61
BSGS16 BSGS16UU	9.5	15	7.5	8.5	3.5 x 6 x 4.5	—	15	0.06	1.02
BSGS25 BSGS25UU	15	20	10	13	6 x 9.5 x 8.5	—	20	0.23	2.15

Dimensions in mm

moment load ratings + load / life formulas. pg.98

NOTE: Models BSGS5, BSGS8, BSGS5UU and BSGS8UU are available in Stainless Steel only.

Ball Slide Guide Extra Wide BSGS-W (Stainless Steel)

BSGS12W ~ 16W

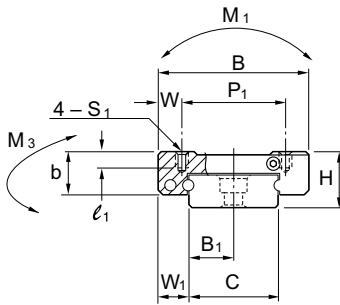

BSGS9W

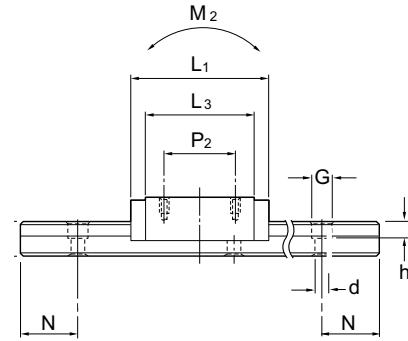
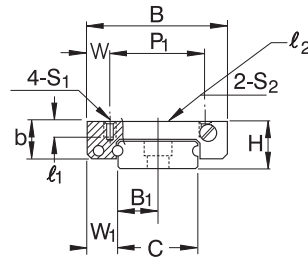

For BSGS16W Guide Rails

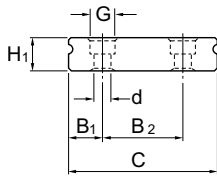

BSGS-WUU

(with double seals)

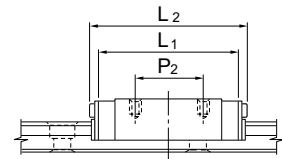
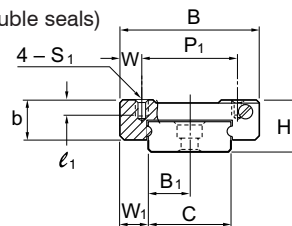

MODEL	DIMENSIONS OF CARRIAGE														BASIC LOAD RATING	
	H	B	L ₂	L ₁	W	P ₁	P ₂	S ₁	ℓ ₁	L ₃	W ₂	S ₂	ℓ ₂	b	C kgf	C ₀ kgf
STAINLESS STEEL																
BSGS9W BSGS9WUU	9	25	31.5	30.1	3.5	19	10	M3	2.8	22.1	12.5	M4	3.5	7	160	250
BSGS12W BSGS12WUU	12	30	39	35.3	4.5	21	12	M3	2.8	28.4	—	—	—	9	230	340
BSGS14W BSGS14WUU	14	40	44.5	40.7	6	28	15	M3	3.5	33.5	—	—	—	11	300	440
BSGS16W BSGS16WUU	16	60	55.5	51.2	7.5	45	20	M4	4.5	42	—	—	—	13	500	720

Dimensions in mm

MODEL	DIMENSIONS OF GUIDE RAIL							WEIGHT		
	H ₁	C	B ₁	B ₂	W ₁	d x G x h	N	Carriage kg	Guide Rail kg/m	
STAINLESS STEEL										
BSGS9W BSGS9WUU	5.2	14	7	—	5.5	3.5 x 6 x 3.2	10	0.02	0.5	
BSGS12W BSGS12WUU	7.5	18	9	—	6	3.5 x 6 x 4.5	10	0.04	0.96	
BSGS14W BSGS14WUU	8	24	12	—	8	4.5 x 8 x 4.5	15	0.08	1.4	
BSGS16W BSGS16WUU	9.5	42	9.5	23	9	4.5 x 8 x 4.5	15	0.15	2.96	

Dimensions in mm

moment load ratings + load / life formulas. pg.98

NOTE: Models BSGS9W and BSGS9WUU are available in Stainless Steel only.

Technical Section Index

General Information **page 83**
Life Formulas **page 85**
Moment Load Formulas & Ratings **page 87**

General Information

1. Ball Slides or Roller Slides

A. Ball slide design offers the following advantages:

- Self cleaning (point contact of balls and shafts does not allow foreign material to interfere).
- Low cost (Ball and shaft materials are common and easily manufactured).

B. Crossed roller slide design offers the following advantages:

- Line contact of roller to shafts offer 8 x 10 times the load capacity of balls.
- Higher over hanging load capacity and low axial play.

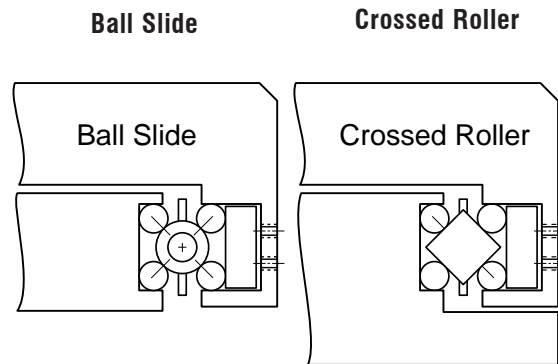

2. Straight Line Design or Recirculating Type

Straight line, or non-recirculating slides, have rolling elements which move on a straight track and are separated by a retainer. The slide reaches the end of its travel when the retainer or rolling element contacts a limiting component, (either a screw head or end cap). This travel limitation is determined by the relationship of the retainer length to the carriage length. Standard slides usually have travel equal to 1/3 the carriage length. Maximum total travel can be as much as 1x the carriage length. Therefore, for more travel, you must specify a longer slide. This design offers extremely low friction and stiction characteristics.

Recirculating slide designs offer travel which is not limited by carriage size. In this design the rolling elements revolve within an oval track inside the carriage. See the Del-Tron® BSG series.

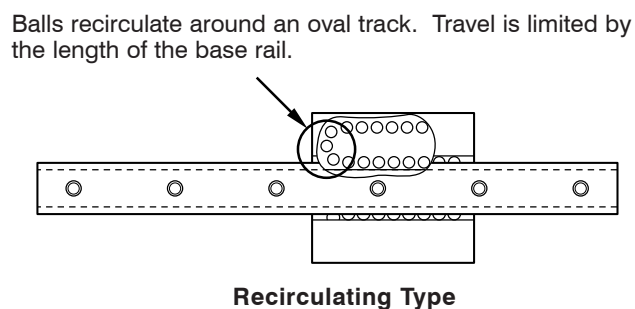
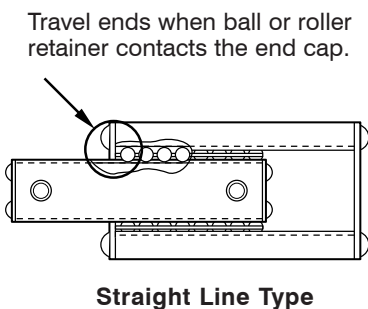

3. Standard Tolerances

Dimensions in Millimeters	
Unless otherwise specified, tolerances are as follows:	
One (1) place decimals	±0.25
Two (2) place decimals	±0.13

4. Custom Slides

Del-Tron's engineering staff will be pleased to assist you in developing custom versions of our linear slides. Our proprietary manufacturing processes allow us to offer completely customized slides built to your requirements even in small quantities in less than eight weeks.

Minor modifications can be provided. Some of the more common modifications we can provide:

- Changes in height, width, or length
- More or less travel
- Increased load capacity
- Light, medium, or heavy preload
- Different holes, threads or hole locations
- Dowel holes and pins
- Reduced or increased axial play
- Multiple carriages on a single base
- Non-standard retainer material
- No anodize or non-standard anodize color
- Corrosion resistant stainless steel components

5. High Temperature Applications

Del-Tron slides can be modified to operate in elevated temperature areas by the substitution of teflon, aluminum, or brass retainers.

6. Static Sensitive Applications

Del-Tron now offers precision linear motion devices that meet low electrostatic discharge requirements common in the semiconductor and electronics industries. The new slides are coated with electroless nickel, an alloy of nickel and phosphorous produced by autocatalytic chemical reduction with hypophosphite. The plating allows static charges to dissipate, helping the slides to meet requirements for automated equipment. Del-Tron® "ESD" electroless nickel plated slides are plated to ASTM standard B 733-97. This process is available for Del-Tron® line of ball slides, crossed roller slides and both ball and crossed roller multi-axis positioning stages.

7. Vacuum Applications

Outgassing of slide components can be reduced or eliminated for vacuum applications by eliminating anodized and oxidized finishes, labels, lubricants, and non-metallic retainers.

8. Preload vs. Axial Play

Many of our slides allow the preload to be set to a specific amount to accommodate the needs of the application. A light, medium, or heavy preload may be ordered. The amount of preload can be expressed as grams of force needed to move either the base or carriage. Please contact our engineering staff to discuss your special preload requirements.

Slide preload and axial play are related.

- Increased preload = less axial play
- Decreased preload = more axial play

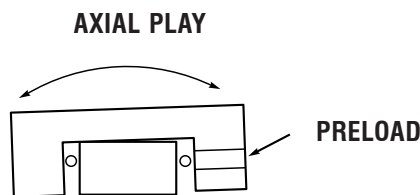

9. Straight Line Accuracy

Straight Line Accuracy = possible runout in any plane

Measured by comparison of the line of travel to a master straight edge, using a gage or indicator mounted on the slides.

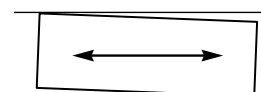
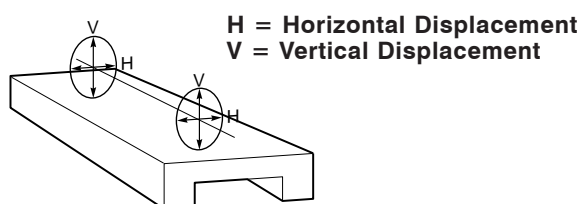

Life Formulas

Linear Ball and Roller Slides

Rated Life

The rated life “L” of a linear slide is the length of travel endured by the slide under a specified condition. Since in reality, life varies from one slide to another, industry normally uses the L10 life rating which is defined as the length of travel that 90% of apparently identical slides will complete before the first evidence of failure.

Speed Factor

The effect of speed on the load rating of a slide can be accounted for by a speed factor:

Formula 1

$$f_s = \sqrt[m]{\frac{760}{V}}$$

where: V = speed of the slide movement in mm/min (when the speed varies during the cycle, the peak value should be used)
 m = 3 for ball slides, or
 m = 10/3 for roller slides

Note: When the speed is less than 760mm/min, $f_s = 1$.

Temperature Factor

When the temperature of the slide exceeds certain limits, it reduces the hardness of contacting elements and consequently affects the load rating of the slide. Therefore, its load rating shall be adjusted by a temperature factor “ft”. The values of this factor are presented in Table 1.

Table 1

Temp. Degree Celsius	Temp. Factor, “ft”	
	Regular Bearing Steel Contacting Elements	Stainless Steel Contacting Elements
104	1	1
149	0.9	1
204	0.75	0.9
260	not recommended	0.75

Note: When specifying slides for elevated temperature service, it should be kept in mind that the delrin retainers found in many slides are not recommended for temperatures above 82 deg. C.

Load Type Factor

In reality, the load endured by a slide can never be absolutely smooth, but rather is a sum of variable forces that include working load, inertial forces, vibrations, impacts, occasional loads, etc. In order to have their influence taken into account, the load rating of the slide shall be adjusted by a load type factor “fw”.

The values of “fw” for calculations per formula (2) and (3) are presented in Table 2.

Table 2

Condition of Load	Value of “fw”
Relatively smooth motion	1 to 1.5
Motion with impacts	2 to 3

Life Formula for Ball and Roller Slides

Based on the above definitions and role of different factors, the real life of linear slides can be obtained from the following formula:

Formula 2

$$L_{10} = \left(\frac{C \times f_s \times f_t}{P_c \times f_w} \right)^m \times (25.4 \times 10^6 \text{ mm})$$

where:

L10 = life of the slide at 90% of reliability as defined above (in millimeters).

C = catalog "load capacity" of the slide in kg. (which is a load that corresponds to an L10 life of 250 million mm, provided the factors fs, ft and fw are equal to 1.

Pc = calculated effective load the slide is subjected to in kg. (fs, ft and fw are factors as described above.)

m = 3 for ball slides, or 10/3 for roller slides.

When other than 90% reliability is required (for instance, "K"% reliability), the known value of L10 shall be multiplied by a reliability factor "fr" so that:

$$L_n = f_r \times L_{10}$$

where:

Ln = rated life at the reliability of K%
(n = 100-K).

The values of the factor "fr" are presented in Table 3.

Table 3

RELIABILITY K%	"Ln" rated life	"fr", reliability factor
50	L50	5.00
90	L10	1.00
95	L5	0.62
97	L3	0.44
99	L1	0.21

The general formula for the life of Del-Tron linear slides is expressed as following:

Example

Formula 3

$$L_n = f_r \times \left(\frac{C \times f_s \times f_t}{P_c \times f_w} \right)^m \times (25.4 \times 10^6 \text{ mm})$$

Design considerations lead to the selection of a ball slide. The available space accommodates the Del-Tron SA2-4 slide. Find the life at 95% reliability (L5 life) under the following conditions:

- Peak speed during the cycle:
V = 3810 mm/min
- Working temperature of slide = 66 deg. C.
- Calculated effective load the slide is subjected to: Pc = 9.1 kg
- Type of load: Moderate vibration, no impacts.

Solution:

- (1) With the formula (1) the speed factor "fs" is found as:

$$f_s = \sqrt[3]{\frac{760}{3810}} = 0.58$$

- (2) The value of the temperature factor "ft" is found in Table 1 as: ft = 1.
- (3) Using Table 2, the value of the type of load factor can be estimated as:
fw = 1.25.
- (4) The value of reliability factor "fr" is found in Table 3 as: fr = 0.62.
- (5) The value of the load capacity for the Del-Tron SA2-4 slide is found in the Del-Tron Catalog as: C = 27.2 kg
- (6) The required life of the slide can then be calculated using formula (3):

$$L_5 = 0.62 \times \left(\frac{27.2 \times .58 \times 1}{9.1 \times 1.25} \right)^3 \times (25.4 \times 10^6) = 42 \times 10^6 \text{ mm}$$

Moment Load Ratings

**Need motor/controller for your Posi-Drive?
Call us. We can supply the complete package.**

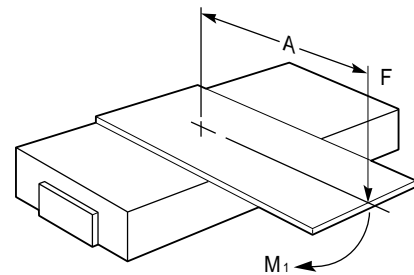
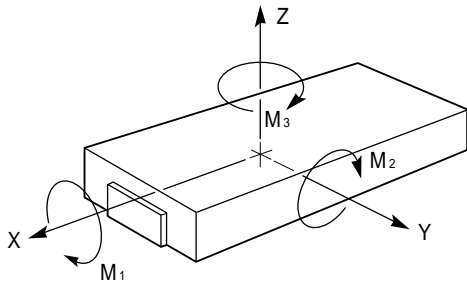

- A = Distance (mm) from slide centerline to line of acting force.
- F = Acting force (kg).
- L = Published load capacity (kg).
- M1, M2, M3 = Moment load rating (kg - mm).
- m1 - m2 - m3 = Acting moment load (kg - mm).

Unit Conversion:
(N·m) x (102) = kg - mm

$$m1 = [F \times A]$$

$$\left[\frac{F}{L} + \frac{m1}{M1} \right] \leq 1$$

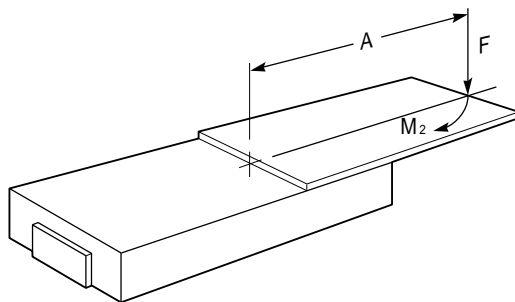

$$m2 = [F \times A]$$

$$\left[\frac{F}{L} + \frac{m2}{M2} \right] \leq 1$$

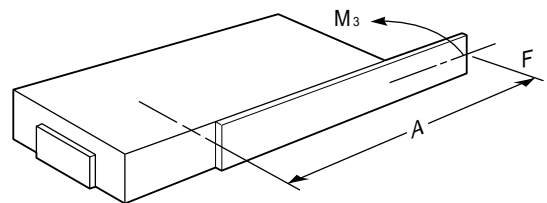

$$m3 = [F \times A]$$

$$\left[\frac{F}{L} + \frac{m3}{M3} \right] \leq 1$$

Moment Load Ratings

Ball Slide Assemblies and Anti-Creep Ball Slide Assemblies

Refer to Page 7 and 10

MODEL #	M1 N·m	M2 N·m	M3 N·m	MODEL #	M1 N·m	M2 N·m	M3 N·m
CA-.5	.01	.01	.02	C-1AC	.01	.02	.03
CA-1	.01	.02	.03	C-2AC	.01	.04	.04
CA-2	.01	.04	.04	C-3AC	.01	.05	.06
CA-3	.01	.05	.06				
DA-1	.06	.11	.11	D-1AC	.06	.11	.11
DA-2	.14	.51	.53	D-2AC	.14	.51	.53
DA-3	.17	.98	1.02	D-3AC	.17	.98	1.02
DA-4	.20	1.52	1.59	D-4AC	.20	1.52	1.59
DA-5	.23	2.02	2.13	D-5AC	.23	2.02	2.13
DA-6	.26	2.60	2.73	D-6AC	.26	2.60	2.73
EA-1	.18	.22	.23	E-1AC	.18	.22	.23
EA-2	.22	.54	.57	E-2AC	.22	.54	.57
EA-3	.26	.98	1.02	E-3AC	.26	.98	1.02
EA-4	.31	1.52	1.59	E-4AC	.31	1.52	1.59
EA-5	.35	2.02	2.13	E-5AC	.35	2.02	2.13
EA-6	.39	2.60	2.73	E-6AC	.39	2.60	2.73
MA-1	.28	.38	.40	M-1AC	.28	.38	.40
MA-2	.34	.98	1.02	M-2AC	.34	.98	1.02
MA-2.5	.37	1.17	1.23	M-2.5AC	.37	1.17	1.23
MA-3	.42	1.49	1.57	M-3AC	.42	1.49	1.57
MA-4	.51	2.27	2.39	M-4AC	.51	2.27	2.39
NA-1	.43	.51	.53	N-1AC	.43	.51	.53
NA-2	.52	1.22	1.28	N-2AC	.52	1.22	1.28
NA-3	.58	2.03	2.14	N-3AC	.58	2.03	2.14
NA-4	.72	3.11	3.26	N-4AC	.72	3.11	3.26
NA-6	.37	5.08	5.34	N-6AC	.37	5.08	5.34
NA-8	1.01	7.51	7.89	N-8AC	1.01	7.51	7.89
NA-10	1.16	10.39	10.91	N-10AC	1.16	10.39	10.91
SA1-1	.63	.68	.71	S1-1AC	.63	.68	.71
SA1-2	.83	1.36	1.42	S1-2AC	.83	1.36	1.42
SA1-3	1.04	2.26	2.37	S1-3AC	1.04	2.26	2.37
SA1-3.5	1.25	3.73	3.91	S1-3.5AC	1.25	3.73	3.91
SA1-4	1.46	5.54	5.81	S1-4AC	1.46	5.54	5.81
SA1-6	1.88	9.15	9.61	S1-6AC	1.88	9.15	9.61
SA1-8	2.29	13.67	14.35	S1-8AC	2.29	13.67	14.35
SA2-1	.96	.90	.95	S2-1AC	.96	.90	.95
SA2-1.5	1.44	2.03	2.14	S2-1.5AC	1.44	2.03	2.14
SA2-2	2.02	3.32	3.49	S2-2AC	2.02	3.32	3.49
SA2-3	2.50	4.70	4.94	S2-3AC	2.50	4.70	4.94
SA2-4	2.88	9.49	9.97	S2-4AC	2.88	9.49	9.97
SA2-6	3.60	15.25	16.02	S2-6AC	3.60	15.25	16.02
SA2-8	4.32	22.37	23.49	S2-8AC	4.32	22.37	23.49
SA3-1	2.47	1.90	1.99	S3-1AC	2.47	1.90	1.99
SA3-1.5	2.88	1.90	1.99	S3-1.5AC	2.88	1.90	1.99
SA3-2	5.11	6.86	7.21	S3-2AC	5.11	6.86	7.21
SA3-3	7.25	12.53	13.15	S3-3AC	7.25	12.53	13.15
SA3-4	9.72	20.53	21.56	S3-4AC	9.72	20.53	21.56
SA3-5	11.12	32.03	33.63	S3-5AC	11.12	32.03	33.63
SA3-6	12.35	40.34	42.35	S3-6AC	12.35	40.34	42.35
SA3-9	15.24	61.45	64.53	S3-9AC	15.24	61.45	64.53
SA3-12	16.89	81.07	85.12	S3-12AC	16.89	81.07	85.12

Moment Load Ratings

Crossed Roller Slide Assemblies

Refer to Page 16

MODEL #	M1 N·m	M2 N·m	M3 N·m	MODEL #	M1 N·m	M2 N·m	M3 N·m
RDA-1	0.43	0.81	.85	RSA1-1	5.50	6.68	7.02
RDA-2	0.71	2.66	2.79	RSA1-2	6.29	9.55	10.03
RDA-3	0.95	4.92	5.17	RSA1-3	7.34	15.59	16.37
RDA-4	1.01	7.59	7.97	RSA1-3.5	8.76	26.10	27.40
RDA-5	1.15	10.12	10.63	RSA1-4	12.84	46.77	49.11
RDA-6	1.30	13.02	13.67	RSA1-6	15.01	73.21	76.87
REA-1	1.05	1.30	1.37	RSA1-8	17.20	102.53	107.66
REA-2	1.53	3.80	3.99	RSA2-1	6.34	6.68	7.02
REA-3	2.06	7.05	7.36	RSA2-1.5	7.21	10.17	10.68
REA-4	2.15	10.63	11.16	RSA2-2	8.46	13.36	14.03
REA-5	2.28	13.16	13.81	RSA2-3	8.46	15.59	16.29
REA-6	2.37	15.62	16.40	RSA2-4	14.80	46.77	49.11
RMA-1	1.98	2.63	2.77	RSA2-6	18.02	76.26	80.05
RMA-2	2.20	6.35	6.66	RSA2-8	21.62	111.85	117.45
RMA-2.5	2.20	7.05	7.40	RSA3-1	18.53	14.24	14.95
RMA-3	2.33	8.20	8.61	RSA3-1.5	21.54	17.90	18.79
RMA-4	2.54	11.39	11.96	RSA3-2	28.72	35.79	37.58
RNA-1	3.18	3.71	3.55	RSA3-3	35.91	59.66	62.64
RNA-2	3.83	8.35	8.77	RSA3-4	35.91	74.57	78.30
RNA-3	5.68	17.36	18.23	RSA3-5	38.92	112.11	117.72
RNA-4	6.96	27.33	28.70	RSA3-6	57.45	167.04	175.39
RNA-6	8.26	48.30	50.72	RSA3-9	60.95	245.81	258.10
RNA-8	8.62	63.86	67.06	RSA3-12	64.17	308.05	323.46
RNA-10	9.27	83.16	87.31				

Precision Series Ball Slides

Refer to Page 19

MODEL #	M1 N·m	M2 N·m	M3 N·m
MA-2SS	.34	.98	1.02
MA-3SS	.60	2.03	2.67
MA-4SS	.78	3.19	3.69
SA2-1SS	.96	.90	.95
SA2-1.5SS	1.44	2.03	2.14
SA2-2SS	2.02	3.32	3.49
SA2-3SS	2.50	4.70	4.94
SA2-4SS	2.88	9.49	9.97
SA3-1SS	2.47	1.90	1.99
SA3-2SS	5.11	6.86	7.21
SA3-3SS	7.25	12.53	13.15
SA3-4SS	9.72	20.53	21.56
SA3-5SS	11.12	32.03	33.63
SA3-6SS	12.35	40.34	42.35
SA5-3SS	8.33	14.41	15.13
SA5-5SS	16.42	60.95	61.84
SA5-7SS	17.78	70.95	74.47

Precision Series Crossed Roller Slides

Refer to Page 19

MODEL #	M1 N·m	M2 N·m	M3 N·m
RSA2-1SS	4.44	4.68	4.91
RSA2-2SS	5.92	9.35	9.82
RSA2-3SS	6.91	10.91	11.40
RSA2-4SS	7.66	12.11	12.66
RSA3-1SS	18.10	15.03	15.79
RSA3-2SS	24.13	30.07	31.57
RSA3-3SS	30.16	50.11	52.62
RSA3-4SS	35.91	62.64	65.77
RSA3-5SS	41.30	72.03	75.64
RSA5-3SS	19.30	72.21	73.75
RSA5-5SS	21.21	79.36	81.05
RSA5-7SS	23.00	92.75	97.39

Moment Load Ratings

High Precision Ball Slides

Refer to Page 22

MODEL #	M1 N-m	M2 N-m	M3 N-m
HPMA-1	.28	.38	.40
HPMA-2	.40	1.03	1.08
HPMA-2.5	.55	1.76	1.85
HPMA-3	.74	2.61	3.72
HPSA2-1	.96	.90	.95
HPSA2-1.5	1.44	2.03	2.14
HPSA2-2	2.02	3.32	3.49
HPSA2-3	2.50	4.70	4.94
HPSA3-1	4.56	3.76	3.98
HPSA3-2	6.92	9.30	9.77
HPSA3-3	8.40	14.52	15.25
HPSA3-4	10.87	22.97	24.12
HPSA3-5	11.94	34.40	36.12
HPSA4-2	11.12	32.03	33.63
HPSA4-3	12.35	40.34	42.35
HPSA4-5	14.05	52.58	53.70
HPSA4-6.5	15.24	61.45	64.53
HPSA4-9	16.89	81.07	85.12
HPSA5-5	16.16	60.46	61.75
HPSA5-7	17.52	70.67	74.21
HPSA5-10	19.42	93.23	97.89

NOTE: Ratings for FB (Flanged Base) type are the same.

High Precision Crossed Roller Slides

Refer to Page 22

MODEL #	M1 N-m	M2 N-m	M3 N-m
HPRSA2-1	5.04	5.31	5.58
HPRSA2-1.5	5.61	8.29	8.58
HPRSA2-2	6.73	10.63	11.16
HPRSA2-3	7.85	12.40	12.96
HPRSA3-1	17.88	14.85	15.60
HPRSA3-2	20.39	25.41	26.68
HPRSA3-3	28.37	47.13	49.49
HPRSA3-4	37.62	65.62	68.90
HPRSA3-5	43.27	75.46	79.24
HPRSA4-2	19.46	56.06	58.86
HPRSA4-3	21.62	70.59	74.12
HPRSA4-5	24.59	92.01	93.97
HPRSA4-6.5	26.67	107.54	112.92
HPRSA4-9	29.55	141.87	148.96
HPRSA5-5	28.27	105.81	108.06
HPRSA5-7	30.67	123.67	129.86
HPRSA5-10	33.98	163.15	171.31

NOTE: Ratings for FB (Flanged Base) type are the same.

Posi-Drive Stages

Refer to Page 27

MODEL #	M1 N-m	M2 N-m	M3 N-m	MODEL #	M1 N-m	M2 N-m	M3 N-m
LSA1-25	.63	.68	.71	LRSA1-25	5.50	6.68	7.02
LSA1-50	.83	1.36	1.42	LRSA1-50	6.29	9.55	10.03
LSA1-75	1.04	2.26	2.37	LRSA1-75	7.34	15.59	16.37
LSA1-100	1.46	5.54	5.81	LRSA1-100	12.84	46.77	49.11
LSA2-25	.96	.90	.95	LRSA2-25	6.34	6.68	7.02
LSA2-38	1.44	2.03	2.14	LRSA2-38	7.06	10.42	11.12
LSA2-50	2.02	3.32	3.49	LRSA2-50	8.46	13.36	14.03
LSA2-75	2.50	4.70	4.94	LRSA2-75	9.86	15.59	16.29
LSA2-100	2.88	9.49	9.97	LRSA2-100	14.80	46.77	49.11
LSA3-25	2.47	1.90	1.99	LRSA3-25	21.54	17.90	18.79
LSA3-50	5.11	6.86	7.21	LRSA3-50	28.72	35.79	37.58
LSA3-75	7.25	12.53	13.15	LRSA3-75	35.91	59.66	62.64
LSA3-100	9.72	20.53	21.56	LRSA3-100	42.75	74.57	78.30
LSA3-150	12.35	40.34	42.35	LRSA3-150	57.45	167.04	175.39
LSA3-200	13.84	49.94	53.92	LRSA3-200	64.35	206.81	223.29
LSA3-250	16.03	71.14	75.16	LRSA3-250	74.54	294.61	311.25
LSA3-300	16.89	81.07	85.12	LRSA3-300	78.78	324.41	352.70

Moment Load Ratings

Ball Slide Positioning Stages & Side Drive Stages

Refer to Page 44

MODEL #	M1 N·m	M2 N·m	M3 N·m	MODEL #	M1 N·m	M2 N·m	M3 N·m
99MM	.11	.11	.11	502MM	2.02	2.02	2.02
101MM	.19	.18	.18	701MM	4.94	4.94	4.94
201MM	.28	.27	.27	702MM	4.94	4.94	4.94
301MM	.50	.50	.50	1201MM	2.05	1.95	1.95
450MM	.96	.96	.96	1203MM	2.05	1.95	1.95
451MM	.96	.96	.96	2201MM	3.21	3.04	3.04
453MM	.96	.96	.96	2202MM	3.21	3.04	3.04
750MM	4.94	4.94	4.94	2203MM	3.21	3.04	3.04
751MM	4.94	4.94	4.94	2204MM	3.21	3.04	3.04
753MM	4.94	4.94	4.94	3201MM	4.25	4.05	4.05
301PMM	.50	.68	.71	3202MM	4.25	4.05	4.05
451PMM	.96	1.13	1.19	3203MM	4.25	4.05	4.05
452PMM	.96	1.13	1.19	3204MM	4.25	4.05	4.05
751PMM	4.94	5.75	6.04	1202PMM	2.89	1.95	2.05
752PMM	4.94	5.75	6.04	1204PMM	2.89	1.95	2.05
401MM	.96	.96	.96	2205PMM	4.80	3.04	3.21
501MM	2.02	2.02	2.02	2206PMM	4.80	3.04	3.21
				3205PMM	4.80	3.04	3.21
				3206PMM	7.11	4.05	4.25

Crossed Roller Positioning Stages & Side Drive Stages

Refer to Page 50

MODEL #	M1 N·m	M2 N·m	M3 N·m	MODEL #	M1 N·m	M2 N·m	M3 N·m
R101MM	1.09	1.04	1.04	R701MM	13.18	13.18	13.18
R201MM	1.64	1.56	1.56	R702MM	13.18	13.18	13.18
R301MM	2.88	2.88	2.88	R1201MM	5.81	5.53	5.53
R450MM	1.92	1.92	1.92	R1203MM	5.81	5.53	5.53
R451MM	1.92	1.92	1.92	R2201MM	9.10	8.60	8.60
R453MM	1.92	1.92	1.92	R2202MM	9.10	8.60	8.60
R750MM	9.88	9.88	9.88	R2203MM	9.10	8.60	8.60
R751MM	9.88	9.88	9.88	R2204MM	9.10	8.60	8.60
R753MM	9.88	9.88	9.88	R3201MM	12.05	11.47	11.47
R301PMM	1.67	2.26	2.37	R3202MM	12.05	11.47	11.47
R451PMM	1.92	2.26	2.37	R3203MM	12.05	11.47	11.47
R452PMM	1.92	2.26	2.37	R3204MM	12.05	11.47	11.47
R751PMM	9.88	11.50	12.07	R1202PMM	8.19	5.53	5.81
R752PMM	9.88	11.50	12.07	R1204PMM	8.19	5.53	5.81
R401MM	1.92	1.92	1.92	R2205PMM	13.60	8.60	9.10
R501MM	3.84	3.84	3.84	R2206PMM	13.60	8.60	9.10
R502MM	3.84	3.84	3.84	R3205PMM	13.60	8.60	9.10
				R3206PMM	20.15	11.47	12.05

Moment Load Ratings

Low Profile Crossed Roller Slide Tables

Refer to Page 62

MODEL #	M1 N·m	M2 N·m	M3 N·m	MODEL #	M1 N·m	M2 N·m	M3 N·m
LPTA-1025	.80	1.29	1.33	LPTA-2095	6.17	20.05	21.06
LPTA-1035	1.04	2.59	2.71	LPTA-2110	7.05	26.45	27.77
LPTA-1045	1.51	4.55	4.79	LPTA-2125	7.64	32.47	34.10
LPTA-1055	1.74	5.36	5.63	LPTA-3055	9.87	14.81	15.55
LPTA-1065	1.94	8.16	8.33	LPTA-3080	14.42	31.09	32.64
LPTA-1075	2.27	11.58	12.17	LPTA-3105	17.24	48.56	50.91
LPTA-1085	2.55	13.93	14.63	LPTA-3130	21.55	74.75	78.49
LPTA-2035	2.35	3.06	3.21	LPTA-3155	24.29	100.22	105.19
LPTA-2050	3.71	6.49	6.80	LPTA-3180	27.82	135.58	142.36
LPTA-2065	4.41	9.92	10.42	LPTA-3205	29.46	157.61	165.52
LPTA-2080	5.58	15.35	16.12				

Crossed Roller Rail Sets

Refer to Page 65

MODEL #	M1 N·m	M2 N·m	M3 N·m	MODEL #	M1 N·m	M2 N·m	M3 N·m
NB1-020	0	1.10	1.15	NB3-200	0	156.18	163.99
NB1-030	0	2.17	2.27	NB3-225	0	191.11	200.67
NB1-040	0	4.15	4.36	NB3-250	0	243.20	255.36
NB1-050	0	6.90	7.24	NB3-275	0	286.35	300.66
NB1-060	0	10.34	10.85	NB3-300	0	349.36	366.83
NB1-070	0	14.56	15.29	NB3-325	0	400.73	420.77
NB1-080	0	18.01	18.90	NB3-350	0	474.74	498.48
NB2-030	0	2.46	2.59	NB4-080	0	27.95	29.35
NB2-045	0	6.17	6.47	NB4-120	0	68.05	71.45
NB2-060	0	11.60	12.19	NB4-160	0	126.23	132.54
NB2-075	0	16.13	16.94	NB4-200	0	200.81	210.85
NB2-090	0	24.40	25.62	NB4-240	0	297.13	311.98
NB2-105	0	30.79	32.32	NB4-280	0	406.91	427.26
NB2-120	0	41.89	44.00	NB4-320	0	533.90	560.60
NB2-135	0	50.14	52.65	NB4-360	0	678.17	712.08
NB2-150	0	64.08	67.28	NB4-400	0	839.62	881.61
NB2-165	0	79.87	83.86	NB4-440	0	1026.77	1078.10
NB2-180	0	97.62	102.50	NB4-480	0	1223.50	1284.67
NB3-050	0	9.86	10.36	NB6-100	0	90.82	95.36
NB3-075	0	19.96	20.96	NB6-150	0	202.02	212.12
NB3-100	0	38.91	40.86	NB6-200	0	350.75	368.29
NB3-125	0	57.23	60.09	NB6-250	0	548.04	575.44
NB3-150	0	87.16	91.51	NB6-300	0	779.78	818.77
NB3-175	0	115.09	120.84	NB6-350	0	1063.19	1116.35
				NB6-400	0	1390.38	1459.90

Moment Load Ratings

Anti-Creep Crossed Roller Rail Sets

Refer to Page 69

MODEL #	M1 N-m	M2 N-m	M3 N-m	MODEL #	M1 N-m	M2 N-m	M3 N-m
NB2-030-AC	0	2.46	2.59	NB3-200-AC	0	156.18	163.99
NB2-045-AC	0	6.17	6.47	NB3-225-AC	0	191.11	200.67
NB2-060-AC	0	11.60	12.19				
NB2-075-AC	0	16.13	16.94	NB4-080-AC	0	27.95	29.35
NB2-090-AC	0	24.40	25.62	NB4-120-AC	0	68.05	71.45
NB2-105-AC	0	30.79	32.32	NB4-160-AC	0	126.23	132.54
NB2-120-AC	0	41.89	44.00	NB4-200-AC	0	200.81	210.85
NB2-135-AC	0	50.14	52.65	NB4-240-AC	0	297.13	311.98
NB2-150-AC	0	64.08	67.28	NB4-280-AC	0	406.91	427.26
NB2-165-AC	0	79.87	83.86				
NB2-180-AC	0	97.62	102.50	NB6-100-AC	0	90.82	95.36
				NB6-150-AC	0	202.02	212.12
NB3-050-AC	0	9.86	10.36	NB6-200-AC	0	350.75	368.29
NB3-075-AC	0	19.96	20.96	NB6-250-AC	0	548.04	575.44
NB3-100-AC	0	38.91	40.86	NB6-300-AC	0	779.78	818.77
NB3-125-AC	0	57.23	60.09	NB6-350-AC	0	1063.19	1116.35
NB3-150-AC	0	87.16	91.51	NB6-400-AC	0	1390.38	1459.90
NB3-175-AC	0	115.09	120.84				

Crossed Roller Slide Tables (Aluminum)

Refer to Page 72

MODEL #	STAINLESS STEEL	M1 N-m	M2 N-m	M3 N-m	MODEL #	STAINLESS STEEL	M1 N-m	M2 N-m	M3 N-m
NBT-1050AM	SS	2.51	6.37	6.69	NBT-3105AM	SS	18.94	47.87	50.27
NBT-1065AM	SS	2.98	9.32	9.78	NBT-3105A-60M	SS	18.94	47.87	50.27
NBT-1080AM	SS	3.80	14.09	14.79	NBT-3130A-75M	SS	20.83	52.66	55.29
NBT-1095AM	SS	4.24	18.24	19.14	NBT-3155AM	SS	24.70	99.21	104.17
NBT-1125AM	SS	5.17	30.61	32.14	NBT-3155A-90M	SS	24.70	99.21	104.17
					NBT-3180AM	SS	30.54	125.30	131.56
NBT-2035A-18M	SS	2.60	4.78	5.02	NBT-3180A-105M	SS	30.54	125.30	131.56
NBT-2050AM	SS	3.47	6.37	6.69	NBT-3205AM	SS	32.28	145.03	152.27
NBT-2050A-30M	SS	3.47	6.37	6.69	NBT-3205A-130M	SS	32.28	145.03	152.27
NBT-2065AM	SS	4.11	9.32	9.78	NBT-3230A-155M	SS	35.51	159.53	167.50
NBT-2065A-40M	SS	4.11	9.32	9.78	NBT-3255A-180M	SS	38.00	170.70	179.22
NBT-2080A-50M	SS	5.23	14.09	14.79	NBT-3280A-205M	SS	41.41	186.06	195.35
NBT-2080AM	SS	5.23	14.09	14.79	NBT-3305A-230M	SS	43.89	197.23	207.07
NBT-2095A-60M	SS	5.84	18.24	19.14					
NBT-2095AM	SS	5.84	18.24	19.14	NBT-4085AM	SS	34.44	45.59	47.87
NBT-2110A-70M	SS	6.64	24.36	25.62	NBT-4125AM	SS	48.05	92.76	97.40
NBT-2125AM	SS	7.14	30.61	32.14	NBT-4165AM	SS	57.90	160.80	168.83
NBT-2125A-80M	SS	7.14	30.61	32.14	NBT-4205AM	SS	69.67	219.04	229.99
NBT-2155A-100M	SS	10.71	45.92	48.22	NBT-4245AM	SS	81.36	305.16	320.42
NBT-2185A-120M	SS	12.86	55.09	57.86					
					NBT-6110AM	SS	55.53	78.82	82.75
NBT-3055AM	SS	10.81	14.52	15.25	NBT-6160AM	SS	95.73	206.38	216.70
NBT-3055A-30M	SS	10.81	14.52	15.25	NBT-6260AM	SS	144.24	523.53	549.70
NBT-3080A-45M	SS	12.97	17.42	18.30	NBT-6360AM	SS	183.18	888.04	932.44

Moment Load Ratings

Anti-Creep Crossed Roller Slide Tables (Aluminum)

Refer to Page 75

MODEL #	M1 N·m	M2 N·m	M3 N·m	MODEL #	M1 N·m	M2 N·m	M3 N·m
NBT-1050AM	2.51	6.37	6.69	NBT-3105AM	18.94	47.87	50.27
NBT-1065AM	2.98	9.32	9.78	NBT-3130A-75M	20.83	52.66	55.29
NBT-1080AM	3.80	14.09	14.79	NBT-3155AM	24.70	99.21	104.17
NBT-1095AM	4.24	18.24	19.14	NBT-3155A-90M	24.70	99.21	104.17
NBT-1125AM	5.17	30.61	32.14	NBT-3180AM	30.54	125.30	131.56
NBT-2035A-18M	2.60	4.78	5.02	NBT-3205AM	32.28	145.03	152.27
NBT-2050AM	3.47	6.37	6.69	NBT-3230A-155M	35.51	159.53	167.50
NBT-2065AM	4.11	9.32	9.78	NBT-4085AM	34.44	45.59	47.87
NBT-2080AM	5.23	14.09	14.79	NBT-4125AM	48.05	92.76	97.40
NBT-2095AM	5.84	18.24	19.14	NBT-4165AM	57.90	160.80	168.83
NBT-2110A-70M	6.64	24.36	25.62	NBT-4205AM	69.67	219.04	229.99
NBT-2125AM	7.14	30.61	32.14	NBT-4245AM	81.36	305.16	320.42
NBT-2155A-100M	10.71	45.92	48.22	NBT-6110AM	55.53	78.82	82.75
NBT-2185A-120M	12.86	55.09	57.86	NBT-6160AM	95.73	206.38	216.70
NBT-3055AM	10.81	14.52	15.25	NBT-6260AM	144.24	523.53	549.70
NBT-3080A-45M	12.97	17.42	18.30	NBT-6360AM	183.18	888.04	932.44

Crossed Roller Slide Tables (Steel)

Refer to Page 78

MODEL #	M1 N·m	M2 N·m	M3 N·m	MODEL #	M1 N·m	M2 N·m	M3 N·m
NBT-1025	.68	.88	.93	NBT-3105	27.12	64.59	67.82
NBT-1035	.92	1.62	1.69	NBT-3130	33.90	99.56	104.54
NBT-1045	1.15	2.54	2.68	NBT-3155	38.21	133.48	140.15
NBT-1055	1.49	3.95	4.15	NBT-3180	43.76	177.18	186.05
NBT-1065	1.83	5.60	5.89	NBT-3205	46.22	205.52	215.80
NBT-1075	2.07	7.38	7.75	NBT-3230	51.77	250.72	263.25
NBT-1085	2.30	9.39	9.86	NBT-3255	55.46	290.66	305.19
NBT-2035	3.17	4.07	4.27	NBT-3280	60.40	340.28	357.30
NBT-2050	4.94	8.53	8.96	NBT-3305	64.10	386.86	406.20
NBT-2065	5.94	13.21	13.87	NBT-4085	49.33	65.75	69.03
NBT-2080	7.54	20.45	21.48	NBT-4125	68.71	133.57	140.25
NBT-2095	8.33	26.72	28.05	NBT-4165	82.80	206.97	217.31
NBT-2110	9.51	35.23	36.99	NBT-4205	99.54	309.65	325.13
NBT-2125	10.30	43.25	45.41	NBT-4245	116.27	432.78	454.41
NBT-2140	11.50	53.93	56.62	NBT-4285	131.24	561.36	589.43
NBT-2155	12.29	63.70	66.89	NBT-4325	146.22	715.15	750.91
NBT-2170	13.48	76.52	80.35	NBT-6110	79.33	125.28	131.54
NBT-2185	14.27	88.07	92.48	NBT-6160	136.84	303.92	319.11
NBT-3055	15.52	19.72	20.70	NBT-6210	172.54	493.83	518.53
NBT-3080	22.69	41.44	43.51	NBT-6260	206.25	723.00	759.14
				NBT-6310	237.98	985.87	1035.17

Moment Load Ratings

Recirculating Ball Slide Guides

Refer to Page 81

MODEL #	M1 N·m	M2 N·m	M3 N·m	MODEL #	M1 N·m	M2 N·m	M3 N·m
BSGS5 BSGS5UU	1.90	1.20	1.50	BSGS9W BSGS9WUU	15.69	10.79	12.76
BSGS8 BSGS8UU	5.20	4.12	4.90	BSGS12W BSGS12WUU	30.40	13.73	16.68
BSGS10 BSGS10UU	11.77	6.87	7.85	BSGS14W BSGS14WUU	51.98	37.27	21.57
BSGS13 BSGS13UU	18.63	8.82	10.79	BSGS16W BSGS16UU	148.11	40.21	48.06
BSGS16 BSGS16UU	40.21	21.57	25.50				
BSGS25 BSGS25UU	98.09	51.00	60.82				

PRICE AND ENGINEERING CHANGES:

Prices, specifications, and engineering information are subject to change without notice. All prices, dimensions, and engineering information in previous catalogs, bulletins, and price lists are superseded.

TERMS OF SALE:

All shipments are FOB our factory, Bethel, CT. Payment terms are net 30 days. Purchase orders are accepted subject only to the conditions and warranty on this page despite conditions or statements to the contrary contained in any purchase order. Risk of loss and title is with purchaser upon delivery to carrier.

Load ratings listed are based on symmetrical loading, theoretical data, and standard definitions of the bearing industry. Maximum load ratings and all other information in this catalog are suggested only, and cannot be guaranteed or warranted by Del-Tron Precision, Inc.. Suitability of the products for the intended use shall be solely determined by the user, and the user shall assume all risk and liability therewith.

DELIVERY:

Shipping dates, not delivery dates are acknowledged because we have no control over the performance of the carrier. Any extension of delivery dates beyond those specified in the original order must be approved by Del-Tron Precision, Inc.

DELAY:

Del-Tron Precision, Inc. shall not be held responsible for any delay or failure to manufacture or make delivery of all or any part of the material ordered due to strikes or other labor disputes or labor troubles, fires, floods, droughts, accidents, insurrections, breakdowns of machinery or manufacturing plant, lack of or inability to obtain raw materials, labor, power or supplies. Federal, State, County or Municipal laws, acts, rules or regulations or any other causes, contingencies or circumstances within or without the United States not subject to the control of Del-Tron Precision, Inc. which prevent or hinder the manufacture or delivery of the material ordered.

QUANTITY REDUCTION/CANCELLATION

No returns if shipment is completed. Charges will be 100% P.O. Value. If order is complete (in-house), charges will be 100% P.O. Value less shipping charges. If order is incomplete (in-house), charges will be based on Actuals: Engineering time spent, Production labor utilized, Material ordered (if special), Material used (if standard), and a 25% Administrative charge over calculated costs.

RESTOCKING CHARGE:

A 15% re-stocking charge based on value being returned, and the customer will be responsible to pay the new adjusted quantity price.

ORDER HOLDS (INITIATED BY CUSTOMER):

Time delays in shipments will require new delivery schedules to be generated, and additional set-up charges or administrative charges will be passed on to the customer.

WARRANTY, EXCLUSIVE REMEDIES & LIMITS OF LIABILITY:

Del-Tron Precision, Inc.'s ("Del-Tron") sole warranty for products is to repair and replace at no charge, products which are defective in workmanship or materials, provided written notice of such defect is supplied to Del-Tron within the warranty period and product is returned to factory without tampering or misuse. No material may be returned under warranty without prior written authorization from Del-Tron. Del-Tron shall prepay the return to purchaser of such authorized products. The warranty period is thirty (30) days after acceptance of the products. Product is deemed accepted when received by purchaser unless Del-Tron is notified in writing within thirty (30) days setting forth in detail how product does not conform to its material specifications. Del-Tron will notify purchaser when such non conformities are corrected. If, by written notice received by Del-Tron within five (5) days following Del-Tron's notification, you identify remaining non-conformities, Del-Tron will correct such non conformities. When such non-conformities are corrected, the product shall be deemed accepted. Del-Tron's liability for its product is limited to such replacement and Del-Tron shall have no liability for products mishandled or misapplied by buyer or its customers.

THE WARRANTIES SET FORTH HEREIN REPLACE ALL OTHER WARRANTIES, EXPRESS, STATUTORY OR IMPLIED, INCLUDING, BUT NOT LIMITED TO, THE IMPLIED WARRANTIES OF MERCHANTABILITY AND FITNESS FOR A PARTICULAR PURPOSE.

In all instances in which damages are sought from Del-Tron regardless of the legal theory upon which the claim is based, Del-Tron shall only be liable for (1) a bodily injury (including death) and (2) damage to real property and tangible personal property for which Del-Tron is legally liable and the amount of any other actual loss or damage arising from Del-Tron's performance or nonperformance pursuant to any Purchase up to the purchase price of the product that caused any damage. Under no circumstances will Del-Tron be liable for losses or damages resulting from third party claims against you or damages by you based upon third party claims (other than those specified in (1) and (2) above or your economic consequential damages (including loss, profits or savings)), incidental damages or punitive damages even though Del-Tron knew of their possibility.

This section sets forth a maximum collective responsibility of Del-Tron, its suppliers, subcontractors and agents, and all sets of parties are intended beneficiaries of this section. The warranty and exclusive remedy and liability limit is governed by the laws of the State of Connecticut and can not be modified or varied except in a writing signed by the purchaser and Del-Tron.





"Simple — Smooth — Straight line design"

Francis J. Clarke Industrial Park
5 Trowbridge Drive, Bethel, CT, 06801
Tel: 203-778-2727
TOLL FREE: 1-800-245-5013 / FAX: 203-778-2721
WEB: www.deltron.com / E-Mail: deltron@deltron.com