

Precision Linear Motion Components & Accessories

Product Guide

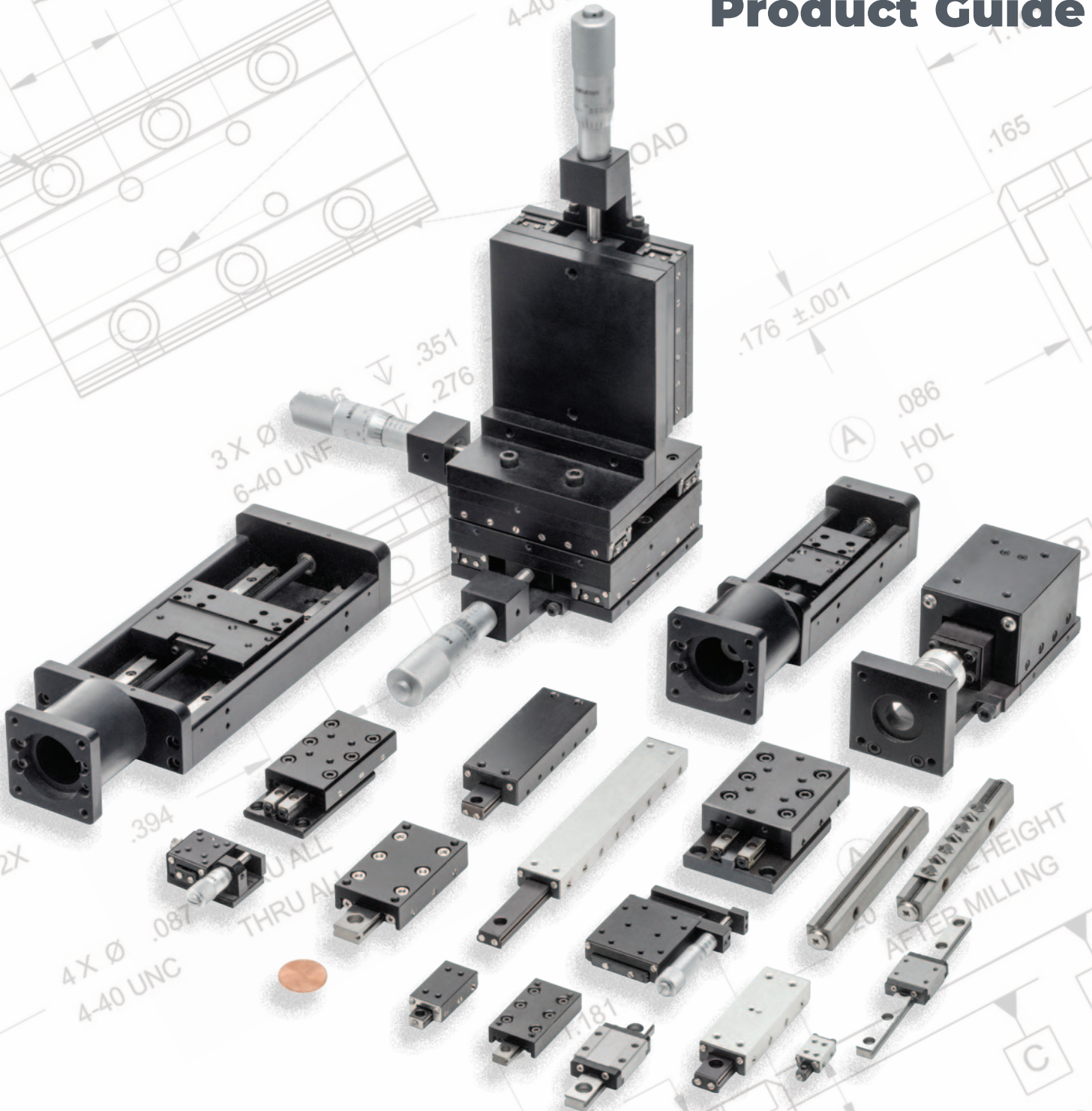

Our Mission

Del-Tron Precision was founded in order to serve the needs of automated equipment manufacturers for innovative, high quality and reasonably priced anti-friction linear bearings.

Our Company

The originator of the sub miniature ball bearing slide assembly; Del-Tron Precision Inc. began operations in 1974 supplying original equipment manufacturers with the world's first commercially available sub miniature ball slide, model D-1.

Since then, thousands of Del-Tron[®] slides have been incorporated into automated equipment throughout the world. Manufacturers of medical analyzing and testing machines, semiconductor and electronic chip processing equipment, printers, plotters, peripherals, assembly systems, lasers and many more have found that Del-Tron[®] slides provide a cost effective anti-friction interface between moving parts in today's increasingly automated equipment.

Del-Tron's modern corporate campus, home to world headquarters, and its principal manufacturing facility, located in the foothills of the Berkshires in Western Connecticut, boasts highly automated computer controlled manufacturing and assembly operations.

Highly skilled workers monitor each manufacturing step, ensuring that consistent and repeatable high quality bearings conform to the published specifications or the customer's particular requirements where applicable. Since its inception, Del-Tron has performed final inspection of 100% of its products.

Del-Tron's operations staff works to assure "just in time" deliveries, if needed, and maintains adequate stock levels of all products at authorized distributor locations in major markets across the U.S.A. and Canada. MHK serves as Del-Tron's European distribution hub in Amberg, Germany. The firm also has locations in Japan and throughout Southeast Asia stand ready to serve the needs of both local and indigenous industries and those of multinational assembly and manufacturing operations worldwide.

Our Quality Policy

We are dedicated to providing our customers with a product of consistent quality that conforms to our specifications and meets or exceeds customer expectations while making on-time delivery at a competitive price.



INDEX

<i>Selection Guide</i>	<i>P 4</i>
<i>Ball Slide Assemblies</i>	<i>P 7</i>
<i>Anti-Creep Ball Slide Assemblies</i>	<i>P 10</i>
<i>Non-Magnetic Ball Slide Assemblies</i>	<i>P 13</i>
<i>Crossed Roller Slide Assemblies</i>	<i>P 16</i>
<i>Precision Series (Ball & Crossed Roller Slides)</i>	<i>P 19</i>
<i>High Precision Series (Ball & Crossed Roller Slides)</i>	<i>P 22</i>
<i>Mini Posi-Drive™ Stages</i>	<i>P 27</i>
<i>Posi-Drive™ Stages</i>	<i>P 34</i>
<i>Friction Free Air Actuators</i>	<i>P 42</i>
<i>Ball Slide Positioning Stages (Micrometer Driven)</i>	<i>P 44</i>
<i>Crossed Roller Positioning Stages (Micrometer Driven)</i>	<i>P 50</i>
<i>Ball & Crossed Roller Positioning Stages (Side Drive Micrometer)</i> ..	<i>P 56</i>
<i>Low Profile Crossed Roller Slide Tables</i>	<i>P 62</i>
<i>Crossed Roller Rail Sets</i>	<i>P 65</i>
<i>Anti-Creep Crossed Roller Rail Sets</i>	<i>P 69</i>
<i>Crossed Roller Slide Tables (Aluminum)</i>	<i>P 72</i>
<i>Anti-Creep Crossed Roller Slide Tables (Aluminum)</i>	<i>P 75</i>
<i>Crossed Roller Slide Tables (Steel)</i>	<i>P 80</i>
<i>Recirculating Ball Slide Guides</i>	<i>P 84</i>
<i>Technical Section</i>	<i>P 89</i>

Selection Guide

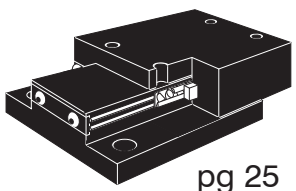
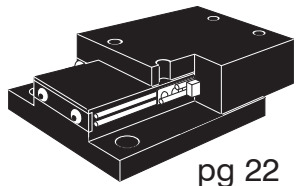
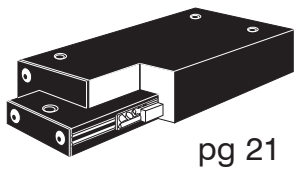
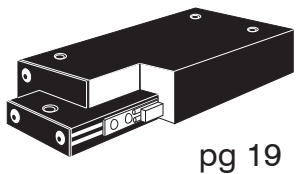
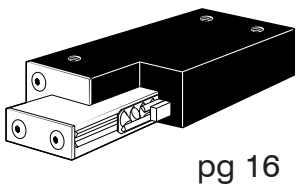
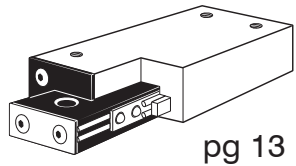
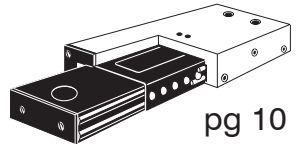
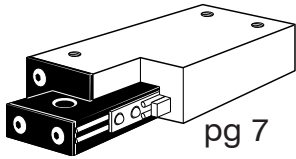

BALL SLIDES

SERIES	LOAD CAPACITY, LB.	TRAVEL	LENGTH	ACCURACY
MINI C	.75-1.5	0.3-1.5	0.52-1.75	0.0005"/"
D-S3 (51 MODELS)	4-205	0.5-12	1.06-15.00	0.0005"/"

ANTI-CREEP BALL SLIDE ASSEMBLIES

SERIES	LOAD CAPACITY, LB.	TRAVEL	LENGTH	ACCURACY
D-AC-S3-AC	4-205	.50-12.00	1.00-15.00	0.0005"/"

NON-MAGNETIC BALL SLIDES

SERIES	LOAD CAPACITY, LB.	TRAVEL	LENGTH	ACCURACY
D-NMS-S3-NMS	1.2-61.5	.50-12.00	1.00-15.00	0.0005"/"

CROSSED ROLLER SLIDES

SERIES	LOAD CAPACITY, LB.	TRAVEL	LENGTH	ACCURACY
MINI RD	30-90	0.5-2.0	1.06-3.06	0.0001"/"
RE-RS3 (47 MODELS)	48-779	0.5-12.0	1.06-15.00	0.0001"/"

PRECISION BALL SLIDE SERIES

SERIES	LOAD CAPACITY, LB.	TRAVEL	LENGTH	ACCURACY
M-2SS-S5-7SS (17 MODELS)	12-170	1.0-7.0	2.56-9.0	0.0001"/"

PRECISION CROSSED ROLLER SLIDE SERIES

SERIES	LOAD CAPACITY, LB.	TRAVEL	LENGTH	ACCURACY
RS2SS-RS5SS (12 MODELS)	80-260	1.0-7.0	2.00-9.00	0.0001"/"

HIGH PRECISION SERIES BALL SLIDES (LOW PROFILE & FLANGE BASE)

SERIES	LOAD CAPACITY, LB.	TRAVEL	LENGTH	ACCURACY
HPM-HPS5 (42 MODELS)	8-225	0.5-10.0	1.00-15.00	0.000040"/"

HIGH PRECISION SERIES CROSSED ROLLER SLIDES (LOW PROFILE & FLANGE BASE)

SERIES	LOAD CAPACITY, LB.	TRAVEL	LENGTH	ACCURACY
HPRS2-HPRS5 (34 MODELS)	90-450	1.0-10.0	2.00-15.00	0.000040"/"

MINI POSI-DRIVE™ & POSI-DRIVE™ STAGES

SERIES	LOAD CAPACITY, LB.	TRAVEL	LENGTH	ACCURACY
LS1-1-C125-LS3-12-B10 (36 MODELS)	8-90	1.0-12.0	4.88-21.63	0.0001"/"
LRS1-1-C125-LRS3-12-B10 (36 MODELS)	15-180	1.0-12.0	4.88-21.63	0.0001"/"

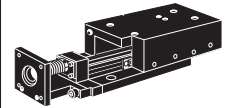

pg 27

Friction Free Air Actuator

SERIES	LOAD CAPACITY, LB.	TRAVEL	LENGTH	ACCURACY
PNRE 1-3	78-94	.50- 2"	3.149- 7.677	0.0001 "/"

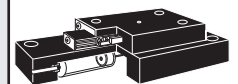

pg 42

BALL SLIDE POSITIONING STAGES (MICROMETER DRIVEN) INCLUDING SIDE DRIVE CONFIGURATION

Available with inch or metric micrometers, in X, XY, and XYZ configurations.

SERIES	LOAD CAPACITY, LB. X, XY, Z	TRAVEL	WORK SURFACE	ACCURACY
99X	5,5,1.25	0.25	0.75 X 0.75	0.0005"/"
101-3204 (25 MODELS, with micrometers)	4-60, 4-60, 1.25-30	0.50-2.00	1.25 x 1.25 to 5.12 x 5.12	0.0005"/"
101P-3206-P (11 MODELS, X and XY ONLY, no micrometers)	4-60, 4-60	0.50-4.00	1.25 x 1.25 to 5.12 x 5.12	0.0005"/"

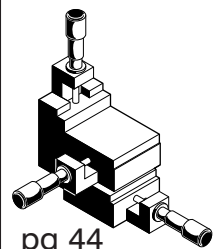

pg 44

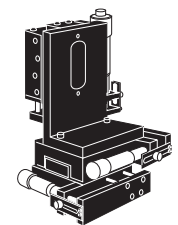

pg 56

CROSSED ROLLER POSITIONING STAGES (MICROMETER DRIVEN) INCLUDING SIDE DRIVE CONFIGURATION

Available with inch or metric micrometers, in X, XY, and XYZ configurations.

SERIES	LOAD CAPACITY, LB. X, XY, Z	TRAVEL	WORK SURFACE	ACCURACY
R99	40, 40, 1.25	0.25	0.75 x 0.75	0.0001"/"
R101-R3204 (25 MODELS, with micrometers)	23-160, 23-160, 1.25-30	0.50-2.00	1.25 x 1.25 to 5.12 x 5.12	0.0001"/"
R101P-R3206P (11 MODELS, X and XY ONLY, no micrometers)	23-160, 23-160	0.50-4.00	1.25 x 1.25 to 5.12 x 5.12	0.0001"/"

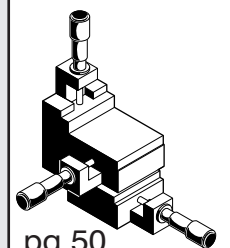

pg 50

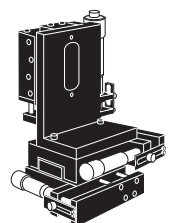

pg 56

Selection Guide

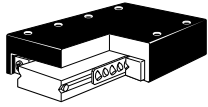

pg 62

LOW PROFILE CROSSED ROLLER TABLES				
SERIES	LOAD CAPACITY, LB.	TRAVEL	LENGTH	ACCURACY
LPT-1025-3205 (21 MODELS) Stainless steel available.	50-825	0.473-5.118	0.984-8.070	0.0001"/"

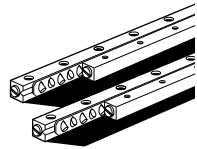

pg 65

CROSSED ROLLER RAIL SETS				
SERIES	LOAD CAPACITY, LB.	TRAVEL	LENGTH	ACCURACY
MINI NB1	44-184	0.473-1.969	0.788-3.150	0.000080"/"
NB2-NB6 (49 MODELS) Stainless steel available.	66-2816	0.709-11.614	1.181-15.748	0.000080"/" to 0.000200"/"

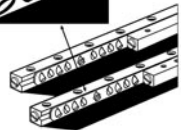

pg 69

ANTI-CREEP CROSSED ROLLER RAIL SETS				
SERIES	LOAD CAPACITY, LB.	TRAVEL	LENGTH	ACCURACY
NB2-AC / NB6-AC (32 MODELS)	66-2816	0.709-11.614	1.181-15.748	0.00020"/" to 0.000240"/"

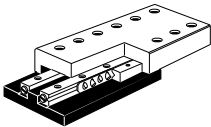

pg 72

CROSSED ROLLER SLIDE TABLES (ALUMINUM)				
SERIES	LOAD CAPACITY, LB.	TRAVEL	LENGTH	ACCURACY
MINI NBT-1A	95-197	1.0-3.0	1.969-4.921	0.0001"/"
NBT-2A-NBT-6A (72 MODELS) Stainless steel available.	66-2032	0.71-9.0	1.378-14.17	0.0001"/"

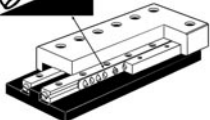

pg 75

ANTI-CREEP CROSSED ROLLER SLIDE TABLES (ALUMINUM)				
SERIES	LOAD CAPACITY, LB.	TRAVEL	LENGTH	ACCURACY
MINI NBT1-AC	96-198	.98-2.75	1.969-4.921	0.0001"/"
NBT2A-AC / NBT6A-AC (31 MODELS)	66-2032	0.71-9.0	1.378-14.17	0.0001"/"

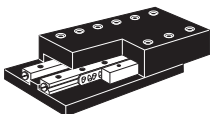

pg 80

CROSSED ROLLER SLIDE TABLES (STEEL)				
SERIES	LOAD CAPACITY, LB.	TRAVEL	LENGTH	ACCURACY
MINI NBT-1	26-88	0.472-1.969	0.984-3.346	0.000080"
NBT-2-NBT-6 (41 MODELS)	88-2640	0.709-9.055	1.378-12.80	0.000080" to 0.00016"

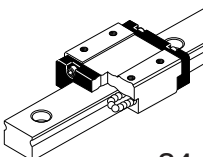

pg 84

BALL SLIDE GUIDES				
SERIES	LOAD CAPACITY, LB.	TRAVEL	LENGTH	ACCURACY
BSGS5-BSGS25	96-2205	0.1-32.0	1.5-35.0	0.0008"
BSGS9W-BSGS16W Stainless steel.	551-1587	2.0-24.0	3.0-26.0	0.0005"

Ball Slides

6 Reasons to choose Del-Tron® Ball Slides

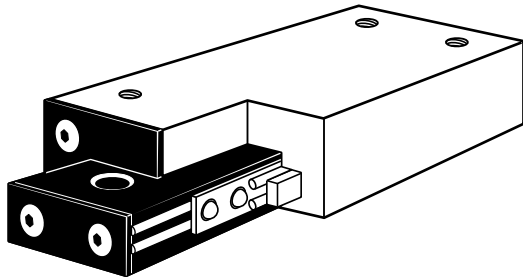

1. **Factory preload adjustment prevents sideplay and backlash.**
2. **Lightweight aluminum carriage and base with high load capacity.**
3. **Built-in holes simplify installation and component mounting.**
4. **Steel shafts, ground over the entire length, reduce coefficient of friction to 0.003.**
5. **Long life, self cleaning ball bearing needs no lubrication.**
6. **Mounting surfaces, parallel to the line of motion, provide straight line accuracy to 0.0005"/" of travel.**

Del-Tron® Ball Slides

Load Ratings and Life Estimates

The rated load capacity of Del-Tron® ball slides may be a mass load on a horizontal slide, or a force load normal to the mounting surface in any position. The rated load must be centered and distributed over the slide, and the base must be fully supported on a flat mounting surface so that the ball slide does not act as a beam subject to concentrated or distributed bending forces. Loads supported by protruding arms reduce accuracy and load capacity by acting as levers or ratio arms, and should be avoided even when load forces are small.

When used at the rated load capacity and moderate speeds, a life of 10 million inches of travel can be expected. The expected life at one half the rated load is 100 million inches.

Friction and Lubrication

The coefficient of friction is lower for linear ball bearings than for rotary bearings, where the peripheral track is shorter on the inner race than on the outer race, causing the ball to skid on one or the other. The balls run exactly equal distances on the pair of tracks in linear bearings, permitting the ball to run without friction, wear, or skidding at any preload. The typical coefficient of friction for Del-Tron® ball slides is 0.003.

Lubrication is recommended for speeds above 1800 inches/min, and is advisable at lower speeds where high loads are applied in continuous duty applications.

Mounting and Accuracy

The mounting surfaces of the ball slide are machined flat and smooth, and parallel to each other and the line of motion. They must be mounted on smooth, flat supports that will not deflect under load. Especially with long slides of small cross section, binding may be caused by distortion of the bottom member when mounted on irregular surfaces. If so, round shims or spacers may be placed over the mounting screws to raise the slide above the surface asperities. Bedding in epoxy resin is also recommended.

The specified accuracy for all standard Del-Tron ball slides is .0005inch/inch of travel. This is measured by comparison of the line of travel to a master straight edge, using a gage or indicator mounted on the slide.

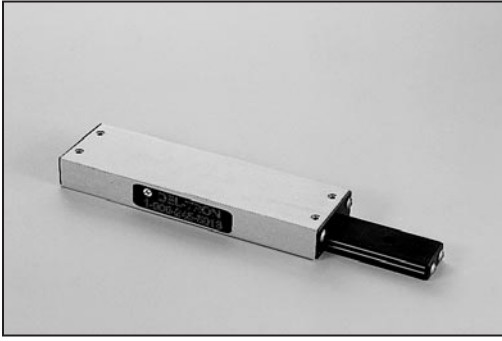

Ball Slide Assemblies

moment load ratings + load / life formulas. pg.91

*Travel is 1/2 distance from center in either direction.

MODEL	TRAVEL *	LOAD CAPACITY LB	WEIGHT OZ	LENGTH A	HEIGHT B	WIDTH C	CARRIAGE HOLE SPACING		BASE DIMENSIONS		
							D	E	HEIGHT F	WIDTH G	HOLE SPACING H
C-.5	.33	.75	.08	.52	.23	.38	.250	.156	.135	.156	.250
C-1	.50	1.5	.10	.75	.23	.38	.375	.156	.135	.156	.375
C-2	1.00	1.5	.15	1.25	.23	.38	.875	.156	.135	.156	.875
C-3	1.50	1.5	.25	1.75	.23	.38	1.375	.156	.135	.156	1.375
D-1	.50	4	.30	1.06	.32	.56	.625	.218	.187	.250	.750
D-2	1.00	8	.50	2.06	.32	.56	1.625	.218	.187	.250	1.375
D-3	2.00	12	.80	3.06	.32	.56	2.625	.218	.187	.250	2.375
D-4	3.00	14	1.1	4.06	.32	.56	3.625	.218	.187	.250	3.375
D-5	4.00	16	1.2	5.06	.32	.56	4.625	.218	.187	.250	3.500
D-6	5.00	18	1.5	6.06	.32	.56	5.625	.218	.187	.250	4.500
E-1	.50	8	.40	1.06	.41	.75	.625	.375	.250	.375	.750
E-2	1.00	10	.90	2.06	.41	.75	1.625	.375	.250	.375	1.375
E-3	2.00	12	1.3	3.06	.41	.75	2.625	.375	.250	.375	2.375
E-4	3.00	14	1.7	4.06	.41	.75	3.625	.375	.250	.375	3.375
E-5	4.00	16	2.1	5.06	.41	.75	4.625	.375	.250	.375	3.500
E-6	5.00	18	2.5	6.06	.41	.75	5.625	.375	.250	.375	4.500
M-1	.50	10	1.2	1.56	.50	1.00	1.250	.437	.250	.500	1.250
M-2	1.00	12	1.7	2.56	.50	1.00	2.250	.437	.250	.500	2.250
M-2.5	1.50	13	1.9	3.06	.50	1.00	2.750	.437	.250	.500	2.750
M-3	2.00	15	2.2	3.56	.50	1.00	3.250	.437	.250	.500	3.250
M-4	3.00	18	5.0	4.56	.50	1.00	4.250	.437	.250	.500	4.250

SERIES	C	D	E	M	N	S1	S2	S3
CARRIAGE 4 HOLES (I)	2-56 UNC-2B THREAD	2-56 UNC-2B THREAD	4-40 UNC-2B THREAD	6-32 UNC-2B THREAD	6-32 UNC-2B THREAD	6-32 UNC-2B THREAD	6-32 UNC-2B THREAD	10-32 UNF-2B THREAD
BASE HOLE d	2-56 UNC	.101	.125	.125	.157	.157	.157	.204
BASE HOLE D ₁	-	.144	.198	.198	.244	.244	.244	.328
BASE HOLE h	-	.100	.125	.125	.150	.150	.150	.205
COUNTER BORE SCREW SIZE	N/A	#2	#4	#4	#6	#6	#6	#10

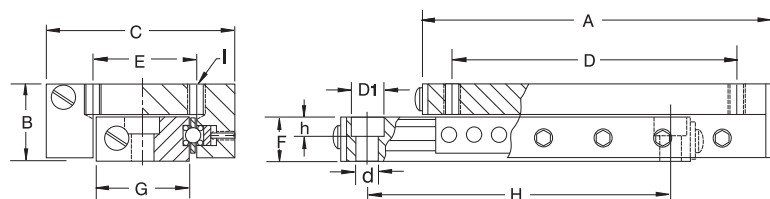

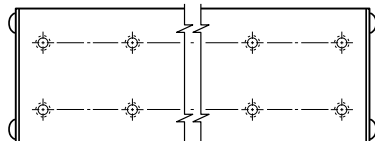

MODEL	# OF HOLES
S3-6	** 6
S3-9	** 8
S3-12	** 10

SPECIFICATIONS:

Straight Line Accuracy
.0005"/inch of travel

Coefficient of Friction
0.003 typical

Positional Repeatability
.0002"

Construction
Aluminum carriage and base,
hardened steel shafts and balls,
mild steel end caps.

Finish
Clear anodize carriage and
black anodize base. Other
finishes on request.

For all metric slides please call
for our metric catalog.

moment load ratings + load / life formulas. pg 91

*Travel is 1/2 distance from center in either direction.

MODEL	TRAVEL *	LOAD CAPACITY LB	WEIGHT OZ	LENGTH A	HEIGHT B	WIDTH C	CARRIAGE HOLE SPACING		BASE DIMENSIONS		
							D	E	HEIGHT F	WIDTH G	HOLE SPACING H
N-1	.75	15	1.3	1.56	.53	1.06	1.250	.437	.312	.500	1.125
N-2	1.50	18	2.3	2.56	.53	1.06	2.250	.437	.312	.500	2.125
N-3	2.00	20	3.0	3.56	.53	1.06	3.250	.437	.312	.500	3.125
N-4	3.00	25	5.2	4.56	.53	1.06	4.000	.437	.312	.500	3.250
N-6	4.00	30	6.0	6.00	.53	1.06	5.500	.437	.312	.500	4.000
N-8	6.00	35	7.0	8.00	.53	1.06	7.500	.437	.312	.500	5.000
N-10	8.00	40	8.0	10.00	.53	1.06	9.500	.437	.312	.500	7.000
S1-1	1.00	15	2.9	2.00	.62	1.50	1.375	.625	.340	.750	1.500
S1-2	2.00	20	4.3	3.00	.62	1.50	2.375	.625	.340	.750	2.500
S1-3	3.00	25	6.0	4.00	.62	1.50	3.375	.625	.340	.750	3.500
S1-3.5	3.50	30	6.7	5.00	.62	1.50	4.375	.625	.340	.750	3.500
S1-4	4.00	35	8.2	6.00	.62	1.50	5.375	.625	.340	.750	4.000
S1-6	6.00	45	9.2	8.00	.62	1.50	7.375	.625	.340	.750	5.000
S1-8	8.00	55	11.5	10.00	.62	1.50	9.375	.625	.340	.750	7.000
S2-1	1.00	20	4.0	2.00	.75	1.75	1.375	.875	.400	.875	1.625
S2-1.5	1.50	30	6.0	2.75	.75	1.75	2.125	.875	.400	.875	2.250
S2-2	2.00	42	6.5	3.25	.75	1.75	2.625	.875	.400	.875	2.750
S2-3	3.00	52	8.0	4.00	.75	1.75	3.375	.875	.400	.875	3.500
S2-4	4.00	60	11.8	6.00	.75	1.75	5.500	.875	.400	.875	4.000
S2-6	6.00	75	15.7	8.00	.75	1.75	7.500	.875	.400	.875	5.000
S2-8	8.00	90	19.5	10.00	.75	1.75	9.500	.875	.400	.875	7.000
S3-1	1.00	30	10.0	2.62	1.00	2.62	2.125	1.250	.625	1.500	2.125
S3-1.5	1.50	35	10.0	2.62	1.00	2.62	1.625	1.250	.625	1.500	1.875
S3-2	2.00	62	15.0	4.00	1.00	2.62	3.000	1.250	.625	1.500	3.375
S3-3	3.00	88	20.8	5.00	1.00	2.62	4.000	1.250	.625	1.500	4.375
S3-4	4.00	118	27.2	6.00	1.00	2.62	5.000	1.250	.625	1.500	5.375
S3-5	5.00	135	31.0	8.00	1.00	2.62	7.000	1.250	.625	1.500	7.375
S3-6	6.00	150	35.2	9.00	1.00	2.62	**3.000	1.250	.625	1.500	7.000
S3-9	9.00	185	46.5	12.00	1.00	2.62	**3.000	1.250	.625	1.500	10.000
S3-12	12.00	205	58.0	15.00	1.00	2.62	**3.000	1.250	.625	1.500	13.000

Anti-Creep Linear Slides

6 Reasons to choose Del-Tron® Anti-Creep™ Ball Slides

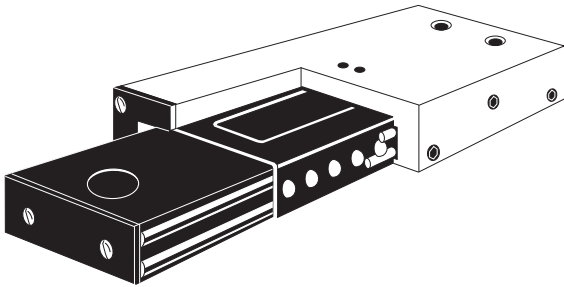

1. Ideal for vertical applications
2. Increased life with overhanging loads
3. Positive internal stops
4. Low friction, straight line design
5. Factory preload controls side play and backlash
6. 0.0005"/inch straight line accuracy

Del-Tron® Anti-Creep™ Slides

In certain applications, uneven loads, improper preload, vertical mounting, or offset forces may cause the ball retainers to become misaligned relative to each other. The misalignment ("creep") can ultimately cause a reduction in overall travel, the need for increased force to achieve full travel and even failure of the assembly.

Del-Tron's® Anti-Creep™ retainer design prevents these problems. The single piece retainer and integral positive end stops prevent ball retainer misalignment and help keep the rolling elements centered in the assembly. The retainer is molded of engineering plastic and slotted in the center. Dowel pins mounted in the base and carriage limit the travel of the retainer and help to keep it centered in the slide for full travel and extended life. In applications in which retainer misalignment is a concern, Del-Tron® Anti-Creep™ slides demonstrate greatly increased life and improved performance. Anti-Creep™ slides have been extensively tested in Del-Tron's internal testing facility and successfully used in the field for over seven years. If you are concerned that your application may induce uneven loads or forces or if the need for a slide operating vertically exists, consider Del-Tron's® Anti-Creep™ retainer design.

Anti-Creep Linear Slides

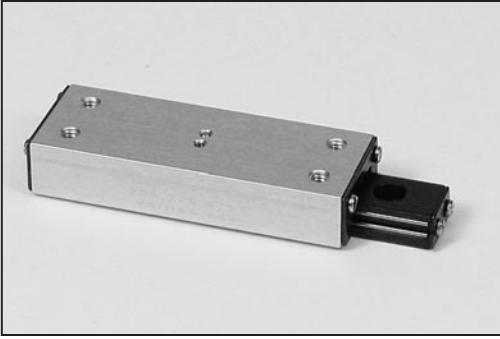

moment load ratings + load / life formulas. pg. 94

*Travel is 1/2 distance from center in either direction.

MODEL	TRAVEL*	LOAD CAPACITY LB	WEIGHT OZ	LENGTH A	HEIGHT B	WIDTH C	CARRIAGE HOLE SPACING		BASE DIMENSIONS		
							D	E	HEIGHT F	WIDTH G	HOLE SPACING H
C-1AC	.50	1.5	.10	.75	.23	.38	.375	.156	.135	.156	.375
C-2AC	1.00	1.5	.15	1.25	.23	.38	.875	.156	.135	.156	.875
C-3AC	1.50	1.5	.25	1.75	.23	.38	1.375	.156	.135	.156	1.375
D-1AC	.50	4	.30	1.06	.32	.56	.625	.218	.187	.250	.750
D-2AC	1.00	8	.50	2.06	.32	.56	1.625	.218	.187	.250	1.375
D-3AC	2.00	12	.80	3.06	.32	.56	2.625	.218	.187	.250	2.375
D-4AC	3.00	14	1.1	4.06	.32	.56	3.625	.218	.187	.250	3.375
D-5AC	4.00	16	1.2	5.06	.32	.56	4.625	.218	.187	.250	3.500
D-6AC	5.00	18	1.5	6.06	.32	.56	5.625	.218	.187	.250	4.500
E-1AC	.50	8	.40	1.06	.41	.75	.625	.375	.250	.375	.750
E-2AC	1.00	10	.90	2.06	.41	.75	1.625	.375	.250	.375	1.375
E-3AC	2.00	12	1.3	3.06	.41	.75	2.625	.375	.250	.375	2.375
E-4AC	3.00	14	1.7	4.06	.41	.75	3.625	.375	.250	.375	3.375
E-5AC	4.00	16	2.1	5.06	.41	.75	4.625	.375	.250	.375	3.500
E-6AC	5.00	18	2.5	6.06	.41	.75	5.625	.375	.250	.375	4.500
M-1AC	.50	10	1.2	1.56	.50	1.00	1.250	.437	.250	.500	1.250
M-2AC	1.00	12	1.7	2.56	.50	1.00	2.250	.437	.250	.500	2.250
M-2.5AC	1.50	13	1.9	3.06	.50	1.00	2.750	.437	.250	.500	2.750
M-3AC	2.00	15	2.2	3.56	.50	1.00	3.250	.437	.250	.500	3.250
M-4AC	3.00	18	5.0	4.56	.50	1.00	4.250	.437	.250	.500	4.250

SERIES	C	D	E	M	N	S1	S2	S3
CARRIAGE 4 HOLES (I)	2-56 UNC-2B THREAD	2-56 UNC-2B THREAD	4-40 UNC-2B THREAD	6-32 UNC-2B THREAD	6-32 UNC-2B THREAD	6-32 UNC-2B THREAD	6-32 UNC-2B THREAD	10-32 UNF-2B THREAD
BASE HOLE d	2-56 UNC	.101	.125	.125	.157	.157	.157	.204
BASE HOLE D ₁	-	.144	.198	.198	.244	.244	.244	.328
BASE HOLE h	-	.100	.125	.125	.150	.150	.150	.205
COUNTER BORE SCREW SIZE	N/A	#2	#4	#4	#6	#6	#6	#10

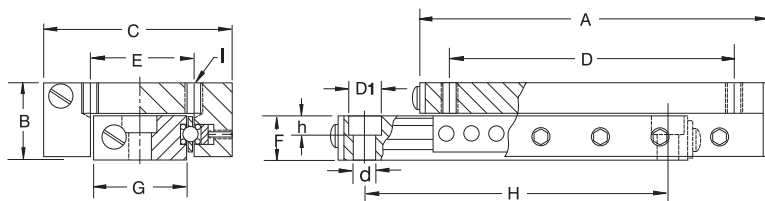

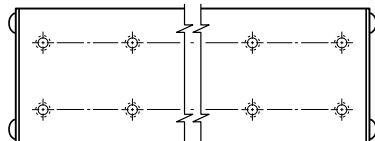

MODEL
 S3-6AC
 S3-9AC
 S3-12AC

OF HOLES
 ** 6
 ** 8
 ** 10

SPECIFICATIONS:

Straight Line Accuracy
 .0005"/inch of travel

Coefficient of Friction
 0.003 typical

Positional Repeatability
 .0002"

Construction
 Aluminum carriage and base,
 hardened steel shafts and balls,
 mild steel end caps.

Finish
 Clear anodize carriage and
 black anodize base. Other
 finishes on request.

For all metric slides please call
 for our metric catalog.

moment load ratings + load / life formulas. pg 94

*Travel is 1/2 distance from center in either direction.

MODEL	TRAVEL *	LOAD CAPACITY LB	WEIGHT OZ	LENGTH A	HEIGHT B	WIDTH C	CARRIAGE HOLE SPACING		BASE DIMENSIONS		
							D	E	HEIGHT F	WIDTH G	HOLE SPACING H
N-1AC	.75	15	1.3	1.56	.53	1.06	1.250	.437	.312	.500	1.125
N-2AC	1.50	18	2.3	2.56	.53	1.06	2.250	.437	.312	.500	2.125
N-3AC	2.00	20	3.0	3.56	.53	1.06	3.250	.437	.312	.500	3.125
N-4AC	3.00	25	5.2	4.56	.53	1.06	4.000	.437	.312	.500	3.250
N-6AC	4.00	30	6.0	6.00	.53	1.06	5.500	.437	.312	.500	4.000
N-8AC	6.00	35	7.0	8.00	.53	1.06	7.500	.437	.312	.500	5.000
N-10AC	8.00	40	8.0	10.00	.53	1.06	9.500	.437	.312	.500	7.000
S1-1AC	1.00	15	2.9	2.00	.62	1.50	1.375	.625	.340	.750	1.500
S1-2AC	2.00	20	4.3	3.00	.62	1.50	2.375	.625	.340	.750	2.500
S1-3AC	3.00	25	6.0	4.00	.62	1.50	3.375	.625	.340	.750	3.500
S1-3.5AC	3.50	30	6.7	5.00	.62	1.50	4.375	.625	.340	.750	3.500
S1-4AC	4.00	35	8.2	6.00	.62	1.50	5.375	.625	.340	.750	4.000
S1-6AC	6.00	45	9.2	8.00	.62	1.50	7.375	.625	.340	.750	5.000
S1-8AC	8.00	55	11.5	10.00	.62	1.50	9.375	.625	.340	.750	7.000
S2-1AC	1.00	20	4.0	2.00	.75	1.75	1.375	.875	.400	.875	1.625
S2-1.5AC	1.50	30	6.0	2.75	.75	1.75	2.125	.875	.400	.875	2.250
S2-2AC	2.00	42	6.5	3.25	.75	1.75	2.625	.875	.400	.875	2.750
S2-3AC	3.00	52	8.0	4.00	.75	1.75	3.375	.875	.400	.875	3.500
S2-4AC	4.00	60	11.8	6.00	.75	1.75	5.500	.875	.400	.875	4.000
S2-6AC	6.00	75	15.7	8.00	.75	1.75	7.500	.875	.400	.875	5.000
S2-8AC	8.00	90	19.5	10.00	.75	1.75	9.500	.875	.400	.875	7.000
S3-1AC	1.00	30	10.0	2.62	1.00	2.62	2.125	1.250	.625	1.500	2.125
S3-1.5AC	1.50	35	10.0	2.62	1.00	2.62	1.625	1.250	.625	1.500	1.875
S3-2AC	2.00	62	15.0	4.00	1.00	2.62	3.000	1.250	.625	1.500	3.375
S3-3AC	3.00	88	20.8	5.00	1.00	2.62	4.000	1.250	.625	1.500	4.375
S3-4AC	4.00	118	27.2	6.00	1.00	2.62	5.000	1.250	.625	1.500	5.375
S3-5AC	5.00	135	31.0	8.00	1.00	2.62	7.000	1.250	.625	1.500	7.375
S3-6AC	6.00	150	35.2	9.00	1.00	2.62	**3.000	1.250	.625	1.500	7.000
S3-9AC	9.00	185	46.5	12.00	1.00	2.62	**3.000	1.250	.625	1.500	10.000
S3-12AC	12.00	205	58.0	15.00	1.00	2.62	**3.000	1.250	.625	1.500	13.000

Non-Magnetic Linear Slides

6 Reasons to choose Del-Tron® Non-Magnetic Ball Slides

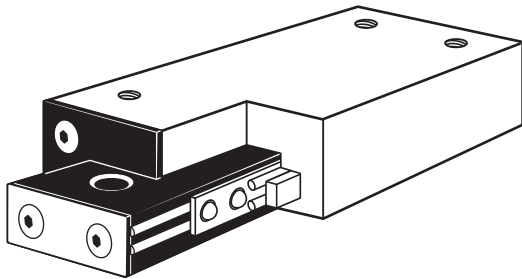

1. Non-Magnetic lightweight design.
2. Silicon nitride ceramic ball bearings, titanium shafts, aluminum carriage and base, brass fasteners.
3. Factory preload minimizes side play and provides low friction.
4. Self cleaning ball bearing design offers long life and requires no lubrication.
5. Standard mounting holes simplify installation.
6. Mounting surfaces, parallel to the line of motion, provide straight line accuracy to 0.0005"/" of travel.

Del-Tron® Ball Slides

Load Ratings and Life Estimates

The rated load capacity of Del-Tron® ball slides may be a mass load on a horizontal slide, or a force load normal to the mounting surface in any position. The rated load must be centered and distributed over the slide, and the base must be fully supported on a flat mounting surface so that the ball slide does not act as a beam subject to concentrated or distributed bending forces. Loads supported by protruding arms reduce accuracy and load capacity by acting as levers or ratio arms, and should be avoided even when load forces are small.

When used at the rated load capacity and moderate speeds, a life of 10 million inches of travel can be expected. The expected life at one half the rated load is 100 million inches.

Friction and Lubrication

The coefficient of friction is lower for linear ball bearings than for rotary bearings, where the peripheral track is shorter on the inner race than on the outer race, causing the ball to skid on one or the other. The balls run exactly equal distances on the pair of tracks in linear bearings, permitting the ball to run without friction, wear, or skidding at any preload. The typical coefficient of friction for Del-Tron® ball slides is 0.003.

Lubrication is recommended for speeds above 1800 inches/min, and is advisable at lower speeds where high loads are applied in continuous duty applications.

Mounting and Accuracy

The mounting surfaces of the ball slide are machined flat and smooth, and parallel to each other and the line of motion. They must be mounted on smooth, flat supports that will not deflect under load. Especially with long slides of small cross section, binding may be caused by distortion of the bottom member when mounted on irregular surfaces. If so, round shims or spacers may be placed over the mounting screws to raise the slide above the surface asperities. Bedding in epoxy resin is also recommended.

The specified accuracy for all standard Del-Tron ball slides is .0005inch/inch of travel. This is measured by comparison of the line of travel to a master straight edge, using a gage or indicator mounted on the slide.

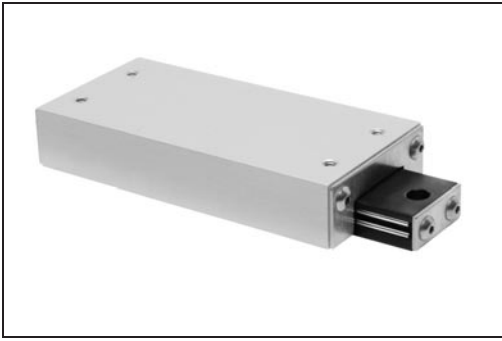

Non-Magnetic Linear Ball Slides

*Travel is 1/2 distance from center in either direction.

MODEL	TRAVEL*	LOAD CAPACITY LB	WEIGHT OZ	LENGTH A	HEIGHT B	WIDTH C	CARRIAGE HOLE SPACING		BASE DIMENSIONS		
							D	E	HEIGHT F	WIDTH G	HOLE SPACING H
D-1-NMS	.50	1.2	.30	1.06	.32	.56	.625	.218	.187	.250	.750
D-2-NMS	1.00	2.4	.50	2.06	.32	.56	1.625	.218	.187	.250	1.375
D-3-NMS	2.00	3.6	.80	3.06	.32	.56	2.625	.218	.187	.250	2.375
D-4-NMS	3.00	4.2	1.1	4.06	.32	.56	3.625	.218	.187	.250	3.375
D-5-NMS	4.00	4.8	1.2	5.06	.32	.56	4.625	.218	.187	.250	3.500
D-6-NMS	5.00	5.4	1.5	6.06	.32	.56	5.625	.218	.187	.250	4.500
<hr/>											
E-1-NMS	.50	2.4	.40	1.06	.41	.75	.625	.375	.250	.375	.750
E-2-NMS	1.00	3.0	.90	2.06	.41	.75	1.625	.375	.250	.375	1.375
E-3-NMS	2.00	3.6	1.3	3.06	.41	.75	2.625	.375	.250	.375	2.375
E-4-NMS	3.00	4.2	1.7	4.06	.41	.75	3.625	.375	.250	.375	3.375
E-5-NMS	4.00	4.8	2.1	5.06	.41	.75	4.625	.375	.250	.375	3.500
E-6-NMS	5.00	5.4	2.5	6.06	.41	.75	5.625	.375	.250	.375	4.500
<hr/>											
M-1-NMS	.50	3.0	1.2	1.56	.50	1.00	1.250	.437	.250	.500	1.250
M-2-NMS	1.00	3.6	1.7	2.56	.50	1.00	2.250	.437	.250	.500	2.250
M-2.5-NMS	1.50	3.9	1.9	3.06	.50	1.00	2.750	.437	.250	.500	2.750
M-3-NMS	2.00	4.5	2.2	3.56	.50	1.00	3.250	.437	.250	.500	3.250
M-4-NMS	3.00	5.4	5.0	4.56	.50	1.00	4.250	.437	.250	.500	4.250

SERIES	D	E	M	N	S1	S2	S3
CARRIAGE 4 HOLES (I)	2-56 UNC-2B THREAD	4-40 UNC-2B THREAD	6-32 UNC-2B THREAD	6-32 UNC-2B THREAD	6-32 UNC-2B THREAD	6-32 UNC-2B THREAD	10-32 UNF-2B THREAD
BASE HOLE d	.101	.125	.125	.157	.157	.157	.204
BASE HOLE D ₁	.144	.198	.198	.244	.244	.244	.328
BASE HOLE h	.100	.125	.125	.150	.150	.150	.205
COUNTER BORE SCREW SIZE	#2	#4	#4	#6	#6	#6	#10

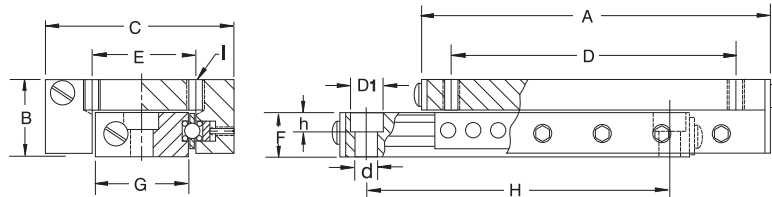

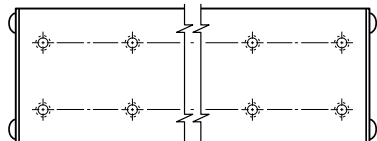

MODEL	# OF HOLES
S3-6	** 6
S3-9	** 8
S3-12	** 10

SPECIFICATIONS:

Straight Line Accuracy
.0005"/inch of travel

Coefficient of Friction
0.003 typical

Positional Repeatability
.0002"

Construction
Silicon nitride ceramic ball bearings, titanium shafts, aluminum carriage base and end caps, brass fasteners.

Finish
Clear anodize carriage and black anodize base. Other finishes on request.

*Travel is 1/2 distance from center in either direction.

MODEL	TRAVEL *	LOAD CAPACITY LB	WEIGHT OZ	LENGTH A	HEIGHT B	WIDTH C	CARRIAGE HOLE SPACING		BASE DIMENSIONS		
							D	E	HEIGHT F	WIDTH G	HOLE SPACING H
N-1-NMS	.75	4.5	1.3	1.56	.53	1.06	1.250	.437	.312	.500	1.125
N-2-NMS	1.50	5.4	2.3	2.56	.53	1.06	2.250	.437	.312	.500	2.125
N-3-NMS	2.00	6.0	3.0	3.56	.53	1.06	3.250	.437	.312	.500	3.125
N-4-NMS	3.00	7.5	5.2	4.56	.53	1.06	4.000	.437	.312	.500	3.250
N-6-NMS	4.00	9.0	6.0	6.00	.53	1.06	5.500	.437	.312	.500	4.000
N-8-NMS	6.00	10.5	7.0	8.00	.53	1.06	7.500	.437	.312	.500	5.000
N-10-NMS	8.00	12.0	8.0	10.00	.53	1.06	9.500	.437	.312	.500	7.000
S1-1-NMS	1.00	4.5	2.9	2.00	.62	1.50	1.375	.625	.340	.750	1.500
S1-2-NMS	2.00	6.0	4.3	3.00	.62	1.50	2.375	.625	.340	.750	2.500
S1-3-NMS	3.00	7.5	6.0	4.00	.62	1.50	3.375	.625	.340	.750	3.500
S1-3.5-NMS	3.50	9.0	6.7	5.00	.62	1.50	4.375	.625	.340	.750	3.500
S1-4-NMS	4.00	10.5	8.2	6.00	.62	1.50	5.375	.625	.340	.750	4.000
S1-6-NMS	6.00	13.5	9.2	8.00	.62	1.50	7.375	.625	.340	.750	5.000
S1-8-NMS	8.00	16.5	11.5	10.00	.62	1.50	9.375	.625	.340	.750	7.000
S2-1-NMS	1.00	6.0	4.0	2.00	.75	1.75	1.375	.875	.400	.875	1.625
S2-1.5-NMS	1.50	9.0	6.0	2.75	.75	1.75	2.125	.875	.400	.875	2.250
S2-2-NMS	2.00	12.6	6.5	3.25	.75	1.75	2.625	.875	.400	.875	2.750
S2-3-NMS	3.00	15.6	8.0	4.00	.75	1.75	3.375	.875	.400	.875	3.500
S2-4-NMS	4.00	18.0	11.8	6.00	.75	1.75	5.500	.875	.400	.875	4.000
S2-6-NMS	6.00	22.5	15.7	8.00	.75	1.75	7.500	.875	.400	.875	5.000
S2-8-NMS	8.00	27.0	19.5	10.00	.75	1.75	9.500	.875	.400	.875	7.000
S3-1-NMS	1.00	9.0	10.0	2.62	1.00	2.62	2.125	1.250	.625	1.500	2.125
S3-1.5-NMS	1.50	10.5	10.0	2.62	1.00	2.62	1.625	1.250	.625	1.500	1.875
S3-2-NMS	2.00	18.6	15.0	4.00	1.00	2.62	3.000	1.250	.625	1.500	3.375
S3-3-NMS	3.00	26.4	20.8	5.00	1.00	2.62	4.000	1.250	.625	1.500	4.375
S3-4-NMS	4.00	35.4	27.2	6.00	1.00	2.62	5.000	1.250	.625	1.500	5.375
S3-5-NMS	5.00	40.5	31.0	8.00	1.00	2.62	7.000	1.250	.625	1.500	7.375
S3-6-NMS	6.00	45.0	35.2	9.00	1.00	2.62	**3.000	1.250	.625	1.500	7.000
S3-9-NMS	9.00	55.5	46.5	12.00	1.00	2.62	**3.000	1.250	.625	1.500	10.000
S3-12-NMS	12.00	61.5	58.0	15.00	1.00	2.62	**3.000	1.250	.625	1.500	13.000

Crossed Roller Slides

6 Reasons to choose Del-Tron® Crossed Roller Slides

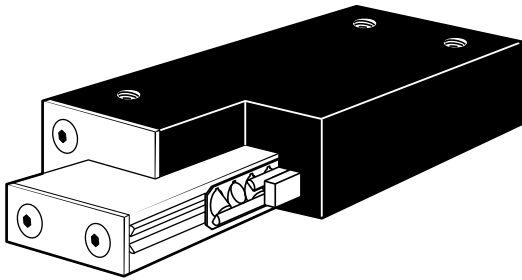

1. Positive stops prevent over travel.
2. Rollers improve load capacity 6-8 times that of balls.
3. Precision ground shafts provide straight line accuracy of 0.0001" per inch of travel.
4. Alternately crossed rollers handle force in any direction.
5. Lightweight aluminum carriage and base.
6. Interchangeable with many types of ball slides.

Del-Tron® Crossed Roller Slides

Del-Tron's new series of crossed roller slides, offer designers additional flexibility in their choice of ready to install components for precision linear transfer.

Our crossed roller slides, when compared to our ball slide products of equal size, offer higher load carrying capacity and, when operating at high cycling rates or with shock and overhanging loads, improved performance. Most importantly, our crossed roller slides provide high accuracy, 0.0001"/inch of travel, and repeatability, 0.0001", exceeding our precision ball slides. Although crossed roller slides cost more than equivalent size ball slides, their overall performance, especially in applications where heavy loads must be moved in compact assemblies, often justifies selection.

Operation

Crossed roller slides physically resemble ball slides except for the bearing design. Specifically, each slide is comprised of an aluminum carriage straddling an aluminum base. Using a bearing system containing cylindrical steel rollers, the carriage glides, almost friction free, over the base.

The rollers, alternately crisscrossed with each other, move between a set of 4, partially flat, parallel, smooth rods on each side of the base. The rollers share a larger contact surface with the rods as compared to the point contact of steel balls. This bearing design allows crossed roller slides to carry larger loads and absorb greater load impacts than equivalent size ball slides.

Crossed roller slides are not as naturally self-cleaning in operation as ball slides. In operating environments, with little or no protection against dust and when heavy loads are not a consideration, consider Del-Tron's ball slides.

Wide Selection

Del-Tron offers over 47 models of crossed roller slides. Load capacities range from 30 lb to 779 lb, with travel from 0.5" to 12". Installation into your system is simple. Counterbored holes in the base permit quick attachment to your assembly. Components attach to the carriage in the existing threaded mounting holes.



Crossed Roller Slide Assemblies

LOAD RATINGS AND LIFE ESTIMATES

Crossed roller slide rated load capacities may be a mass load on a horizontal slide, or a force load normal to the mounting surface in any position. The rated load must be centered and distributed over the slide, and the base must be supported on a flat mounting surface. Avoid concentrated or distributed bending forces.

At rated load capacity and moderate speeds, expected life is 10 million inches of travel. The expected life at one half the rated load is 100 million inches.

LUBRICATION

The crossed roller slides are lightly lubricated during assembly. Additional lubrication is required for speeds above 1200 inches/min. and is advisable at lower speeds where high loads are applied in continuous duty applications.

MOUNTING

Mount the crossed roller slides on flat surfaces to provide full support to the base.

moment load ratings + load / life formulas. pg. 95

*Travel is 1/2 distance from center in either direction.

MODEL	TRAVEL*	LOAD CAPACITY LB	WEIGHT OZ	LENGTH A	HEIGHT B	WIDTH C	CARRIAGE HOLE SPACING		BASE DIMENSIONS		
							D	E	HEIGHT F	WIDTH G	HOLE SPACING H
RD-1	.50	30	0.4	1.06	.32	.56	.625	.218	.187	.250	.750
RD-2	1.00	55	0.6	2.06	.32	.56	1.625	.218	.187	.250	1.375
RD-3	2.00	66	0.9	3.06	.32	.56	2.625	.218	.187	.250	2.375
RD-4	3.00	71	1.2	4.06	.32	.56	3.625	.218	.187	.250	3.375
RD-5	4.00	80	1.3	5.06	.32	.56	4.625	.218	.187	.250	3.500
RD-6	5.00	90	1.6	6.06	.32	.56	5.625	.218	.187	.250	4.500
RE-1	.50	48	0.5	1.06	.41	.75	.625	.375	.250	.375	.750
RE-2	1.00	78	1.0	2.06	.41	.75	1.625	.375	.250	.375	1.375
RE-3	2.00	94	1.4	3.06	.41	.75	2.625	.375	.250	.375	2.375
RE-4	3.00	98	1.8	4.06	.41	.75	3.625	.375	.250	.375	3.375
RE-5	4.00	104	2.2	5.06	.41	.75	4.625	.375	.250	.375	3.500
RE-6	5.00	108	2.6	6.06	.41	.75	5.625	.375	.250	.375	4.500
RM-1	.50	70	1.3	1.56	.50	1.00	1.250	.437	.250	.500	1.250
RM-2	1.00	78	1.8	2.56	.50	1.00	2.250	.437	.250	.500	2.250
RM-2.5	1.50	78	2.0	3.06	.50	1.00	2.750	.437	.250	.500	2.750
RM-3	2.00	83	2.3	3.56	.50	1.00	3.250	.437	.250	.500	3.250
RM-4	3.00	90	2.8	4.56	.50	1.00	4.250	.437	.250	.500	4.250

SERIES	RD	RE	RM	RN	RS1	RS2	RS3
CARRIAGE 4 HOLES (I)	2-56 UNC-2B THREAD	4-40 UNC-2B THREAD	6-32 UNC-2B THREAD	6-32 UNC-2B THREAD	6-32 UNC-2B THREAD	6-32 UNC-2B THREAD	10-32 UNF-2B THREAD
BASE HOLE d	.101	.125	.125	.157	.157	.157	.204
BASE HOLE D1	.144	.198	.198	.244	.244	.244	.328
BASE HOLE h	.100	.125	.125	.150	.150	.150	.205
COUNTER BORE SCREW SIZE	#2	#4	#4	#6	#6	#6	#10

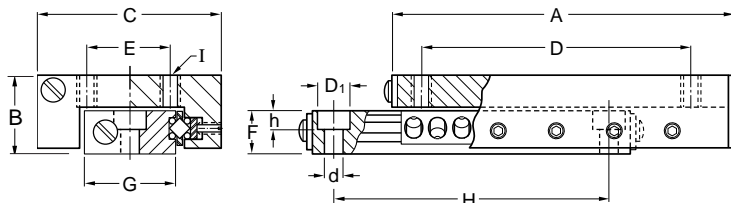

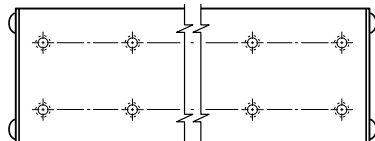

MODEL	# OF HOLES
RS3-6	** 6
RS3-9	** 8
RS3-12	** 10

SPECIFICATIONS:

Straight line accuracy	.0001"/inch of travel
Positional repeatability	.0001"
Coefficient of friction	0.003, typical
Construction	Aluminum carriage and base, hardened steel rods and rollers, stainless steel end caps.
Finish	Black anodize. Other finishes on request.

For all metric slides please call for our metric catalog.

moment load ratings + load / life formulas. pg. 95

MODEL	TRAVEL *	LOAD CAPACITY LB	WEIGHT OZ	LENGTH A	HEIGHT B	WIDTH C	CARRIAGE HOLE SPACING		BASE DIMENSIONS		
							D	E	HEIGHT F	WIDTH G	HOLE SPACING H
RN-1	.75	110	1.4	1.56	.53	1.06	1.250	.437	.312	.500	1.125
RN-2	1.50	132	2.4	2.56	.53	1.06	2.250	.437	.312	.500	2.125
RN-3	2.00	220	3.1	3.56	.53	1.06	3.250	.437	.312	.500	3.125
RN-4	3.00	264	5.3	4.56	.53	1.06	4.000	.437	.312	.500	3.250
RN-6	4.00	285	6.1	6.00	.53	1.06	5.500	.437	.312	.500	4.000
RN-8	6.00	298	7.2	8.00	.53	1.06	7.500	.437	.312	.500	5.000
RN-10	8.00	320	8.2	10.00	.53	1.06	9.500	.437	.312	.500	7.000
RS1-1	1.00	132	3.0	2.00	.62	1.50	1.375	.625	.340	.750	1.500
RS1-2	2.00	176	4.5	3.00	.62	1.50	2.375	.625	.340	.750	2.500
RS1-3	3.00	176	6.2	4.00	.62	1.50	3.375	.625	.340	.750	3.500
RS1-3.5	3.50	210	6.9	5.00	.62	1.50	4.375	.625	.340	.750	3.500
RS1-4	4.00	308	8.4	6.00	.62	1.50	5.375	.625	.340	.750	4.000
RS1-6	6.00	360	9.4	8.00	.62	1.50	7.375	.625	.340	.750	5.000
RS1-8	8.00	413	11.7	10.00	.62	1.50	9.375	.625	.340	.750	7.000
RS2-1	1.00	132	4.1	2.00	.75	1.75	1.375	.875	.400	.875	1.625
RS2-1.5	1.50	150	6.1	2.75	.75	1.75	2.125	.875	.400	.875	2.250
RS2-2	2.00	176	6.6	3.25	.75	1.75	2.625	.875	.400	.875	2.750
RS2-3	3.00	176	8.2	4.00	.75	1.75	3.375	.875	.400	.875	3.500
RS2-4	4.00	308	12.1	6.00	.75	1.75	5.500	.875	.400	.875	4.000
RS2-6	6.00	375	16.0	8.00	.75	1.75	7.500	.875	.400	.875	5.000
RS2-8	8.00	450	19.8	10.00	.75	1.75	9.500	.875	.400	.875	7.000
RS3-1	1.00	225	10.3	2.62	1.00	2.62	2.125	1.250	.625	1.500	2.125
RS3-1.5	1.50	264	10.3	2.62	1.00	2.62	1.625	1.250	.625	1.500	1.875
RS3-2	2.00	352	16.0	4.00	1.00	2.62	3.000	1.250	.625	1.500	3.375
RS3-3	3.00	440	22.4	5.00	1.00	2.62	4.000	1.250	.625	1.500	4.375
RS3-4	4.00	440	28.8	6.00	1.00	2.62	5.000	1.250	.625	1.500	5.375
RS3-5	5.00	473	33.0	8.00	1.00	2.62	7.000	1.250	.625	1.500	7.375
RS3-6	6.00	704	38.4	9.00	1.00	2.62	**3.000	1.250	.625	1.500	7.000
RS3-9	9.00	740	48.2	12.00	1.00	2.62	**3.000	1.250	.625	1.500	10.000
RS3-12	12.00	779	61.0	15.00	1.00	2.62	**3.000	1.250	.625	1.500	13.000

Precision Series

6 Reasons to choose Del-Tron® Precision Series (Ball or Crossed Roller Slides)

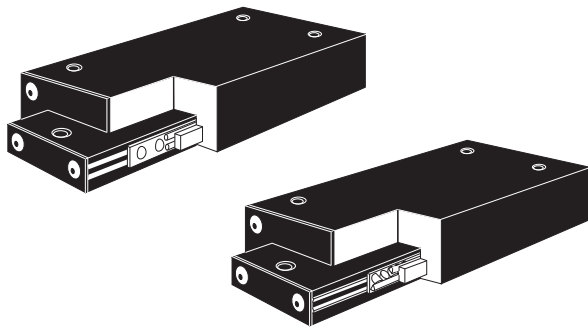

1. Corrosion resistant hardened 400 series stainless steel internal components
2. Up to 5" wide cross section.
3. Interchangeable with other manufacturer's products.
4. Low friction straight line design.
5. Adjustable preload.
6. Straight line design with 0.000050" repeatability

Precision Series (Ball or Crossed Roller Slides)

Del-Tron's Precision Series Ball and Roller Slides offer the designer an aluminum base and carriage with hardened stainless components for superior corrosion resistance and less chance of particulate contamination. Available in standard low profile mounting, the designer can choose a style of bearing and type of rolling element specifically to meet the needs of the most particular applications.

Preload can be adjusted to change the friction and axial play characteristics therefore customizing the slide to its intended use. A new 5-inch wide cross section allows the movement of bulky devices without the necessity of constructing tables with more than one unit.

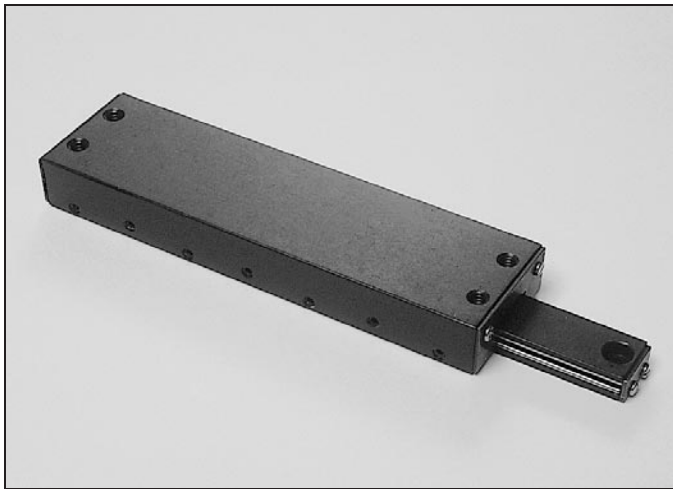

Precision Series Ball Slides

SPECIFICATIONS:

Straight Line Accuracy

0.0001"/" of travel.

Repeatability

0.000050".

Coefficient of Friction

0.002.

Construction

Aluminum carriage and base.
Hardened 400 series stainless steel balls, shafts, pre-load gibs.
Interchangeable with other manufacturers. Economical Ball Slide design.

Finish

Black Anodize. Other finishes on request.

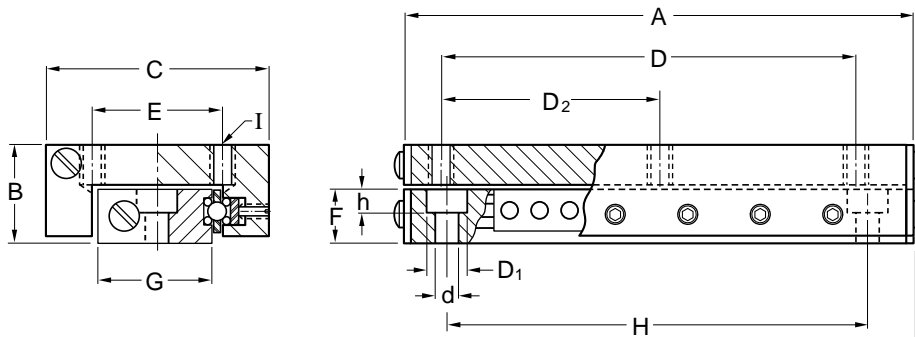

moment load ratings + load / life formulas. pg. 95

*Travel is 1/2 distance from center in either direction.

Model	Travel* (in.)	LOAD CAPACITY		A	B	C	D	d	D ₁	D ₂	E	F	G	H	h	I
		Lbs.	Weight (lbs.)													
M-2SS	1.0	12	0.125	2.56			2.250			-				2.250		
M-3SS	2.0	20	0.175	3.56	.50	1.00	3.250	.125	.198	-	.437	.25	.40	3.250	.125	#6-32
M-4SS	3.0	23	0.225	4.56			4.250			-				4.250		
S2-1SS	1.0	20	0.25	2.00			1.375			-				1.625		
S2-1.5SS	1.5	32	0.34	2.75			2.125			-				2.250		
S2-2SS	2.0	44	0.41	3.25	.75	1.75	2.625	.157	.240	-	.875	.40	.87	2.750	.145	#6-32
S2-3SS	3.0	54	0.50	4.00			3.375			-				3.500		
S2-4SS	4.0	62	0.63	5.00			4.375			-				4.500		
S3-1SS	1.0	35	0.65	2.62			2.125			-				2.125		
S3-2SS	2.0	64	1.00	4.00			3.000			-				3.375		
S3-3SS	3.0	92	1.25	5.00	1.00	2.62	4.000	.204	.328	-	1.250	.61	1.50	4.375	.205	#10-32
S3-4SS	4.0	122	1.50	6.00			5.000			-				5.375		
S3-5SS	5.0	139	1.75	8.00			7.000			-				7.375		
S3-6SS	6.0	154	2.25	9.00			6.000			3.000				7.000		
S5-3SS	3.0	92	2.25	5.00			4.000			2.000				4.000		
S5-5SS	5.0	142	3.25	7.00	1.00	5.00	6.000	.281	.412	3.000	4.000	.61	3.87	6.000	.280	1/4-20
S5-7SS	7.0	170	4.25	9.00			8.000			4.000				8.000		



Precision Series Crossed Roller Slides

SPECIFICATIONS:

Straight Line Accuracy
0.0001"/" of travel.

Repeatability
0.000050".

Coefficient of Friction
0.002.

Finish
Black Anodize. Other finishes on request.

Construction

Aluminum carriage and base.
Hardened 400 series stainless steel rollers, shafts, pre-load gibs.
Interchangeable with other manufacturers. Load capacities up to 410 lbs. Crossed Roller design offers self-aligning ways and greater load capacity.

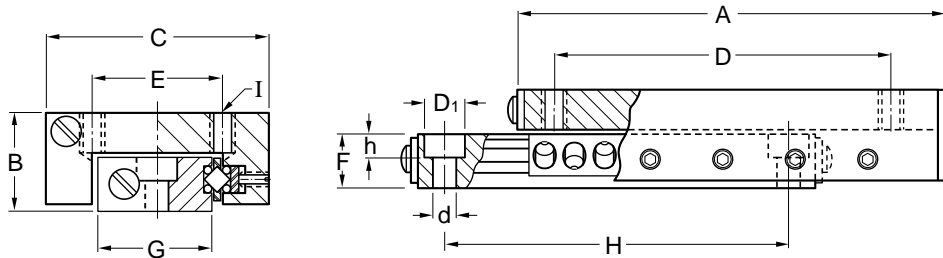

moment load ratings + load / life formulas. pg. 95

*Travel is 1/2 distance from center in either direction.

Model	Travel* (in.)	LOAD CAPACITY		A	B	C	D	d	D ₁	D ₂	E	F	G	H	h	I
		Lbs.	Weight (lbs.)													
RS2-1SS	1.0	80	0.28	2.00			1.375			-				1.625		
RS2-2SS	2.0	120	0.46	3.25	.75	1.75	2.625	.157	.244	-	.875	.40	.87	2.750	.150	#6-32
RS2-3SS	3.0	130	0.56	4.00			3.375			-				3.500		
RS2-4SS	4.0	140	0.63	5.00			4.375			-				4.500		
RS3-1SS	1.0	210	0.66	2.62			2.125			-				2.125		
RS3-2SS	2.0	240	1.00	4.00	1.00	2.62	3.000	.204	.328	-	1.250	.61	1.50	3.375	.205	#10-32
RS3-3SS	3.0	340	1.25	5.00			4.000			-				4.375		
RS3-4SS	4.0	380	1.50	6.00			5.000			-				5.375		
RS3-5SS	5.0	410	2.00	8.00			7.000			-				7.375		
RS5-3SS	3.0	220	2.25	5.00			4.000			2.000				4.000		
RS5-5SS	5.0	240	3.25	7.00	1.00	5.00	6.000	.281	.412	3.000	4.000	.61	3.87	6.000	.280	1/4-20
RS5-7SS	7.0	260	4.25	9.00			8.000			4.000				8.000		

High Precision Series

6 Reasons to choose Del-Tron® High Precision Series (Ball or Crossed Roller Slides)

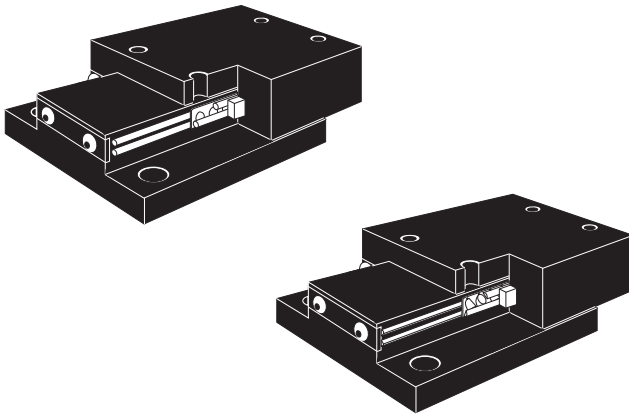

1. Stable flanged base style available
2. Superior accuracy and repeatability.
3. Precision ground carriage and base.
4. Corrosion resistant hardened stainless steel internal components.
5. Bigger cross sections and lengths for heavy loads and large moving parts.
6. Smooth low friction motion.

High Precision Series (Ball or Crossed Roller Slides)

Del-Tron's High Precision Series Ball and Crossed Roller Slides offer the designer highly accurate travel characteristics. 0.000040" per inch of travel with superior repeatability of 0.000020" . The base and carriage inner surfaces are ground to submicron tolerances while the mounting surfaces are flat to within 0.0001" per inch.

The standard low profile style incorporates a base which is surrounded by the carriage leaving little surface to attract and hold contaminants. A flanged base style is offered to allow robust mounting at 4 points to assure stability in high impact or rough duty environments.

These slides utilize Del-Tron's straight line design which allows lower friction characteristics along with the option to manipulate the preload to adjust to the needs of the application.

New larger widths and lengths up to 5.75" wide and 15" long increase the versatility of this design.

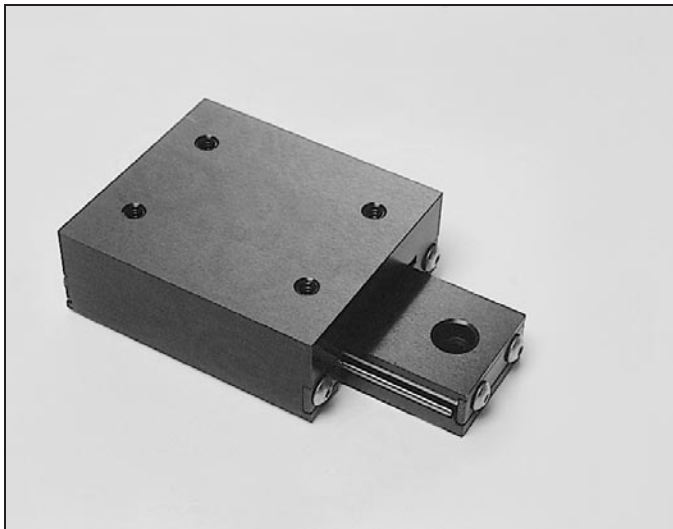

High Precision Series Ball Slides (Low Profile)

SPECIFICATIONS:

Straight Line Accuracy
0.000040"/" of travel.

Repeatability
0.000020".

Coefficient of Friction
0.002.

Finish
Black Anodize. Other finishes on request.

Construction

Aluminum carriage and base. Hardened 400 series stainless steel balls, shafts, pre-load gibs. Interchangeable with other manufacturers. Carriage and base ground to optical flatness. Bearing way surfaces held to submicron tolerances. Carriage surface flat to 0.0001"/". Ball Slide design offers low rolling resistance and economical price.

HPM SERIES ONLY

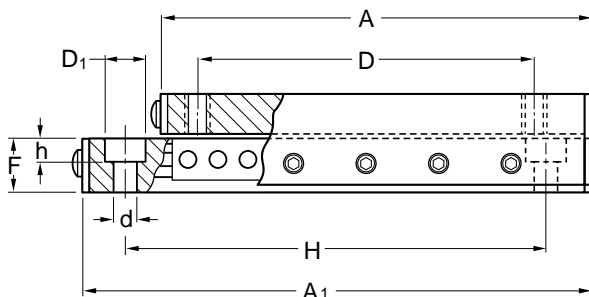
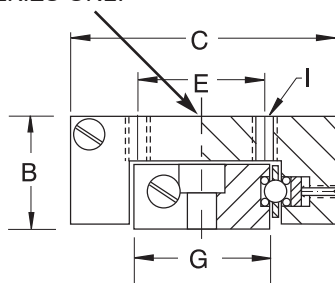

moment load ratings + load / life formulas. pg. 96

*Travel is 1/2 distance from center in either direction.

Model	Travel* (in.)	LOAD CAPACITY		A	A ₁	B	C	D	d	D ₁	E	F	G	H	h	I
		Lbs.	Weight (lbs.)													
HPM-1	0.5	8	0.06	1.00	1.25			0.625						0.750		
HPM-2	1.0	15	0.11	1.75	2.00	.500	1.00	1.375	.125	.198	CL	0.24	0.40	1.500	.125	#4-40
HPM-2.5	1.5	25	0.16	2.50	2.75			2.125						2.250		
HPM-3	2.0	30	0.20	3.25	3.50			2.875						3.000		
HPS2-1	1.0	25	0.28	2.00	2.25			1.375						1.625		
HPS2-1.5	1.5	31	0.38	2.75	3.00	.750	1.75	2.125	.157	.240	0.875	0.40	0.87	2.250	.145	#6-32
HPS2-2	2.0	42	0.46	3.25	3.50			2.625						2.750		
HPS2-3	3.0	51	0.56	4.00	4.25			3.375						3.500		
HPS3-1	1.0	72	0.66	2.62	2.62			2.125						2.125		
HPS3-2	2.0	84	1.00	4.00	4.37			3.000						3.375		
HPS3-3	3.0	102	1.25	5.00	5.37	1.000	2.62	4.000	.204	.328	1.250	0.62	1.50	4.375	.205	#10-32
HPS3-4	4.0	132	1.50	6.00	6.37			5.000						5.375		
HPS3-5	5.0	145	2.00	8.00	8.37			7.000						7.375		
HPS4-2	2.0	130	2.00	4.00	4.50			2.000						2.500		
HPS4-3	3.0	140	2.88	5.75	6.25			3.750						4.250		
HPS4-5	5.0	160	4.00	8.00	8.50	1.375	3.50	6.000	.204	.328	2.000	0.62	1.98	6.500	.205	#10-32
HPS4-6.5	6.5	175	5.13	10.25	10.75			8.250						8.750		
HPS4-9	9.0	200	7.00	14.00	14.50			12.000						12.500		
HPS5-5	5.0	150	10.00	8.25	8.75			6.250						6.250		
HPS5-7	7.0	180	14.52	12.00	12.50	2.000	5.75	10.000	.281	.412	4.000	0.98	3.70	10.000	.280	1/4-20
HPS5-10	10.0	225	18.15	15.00	15.50			13.000						13.000		

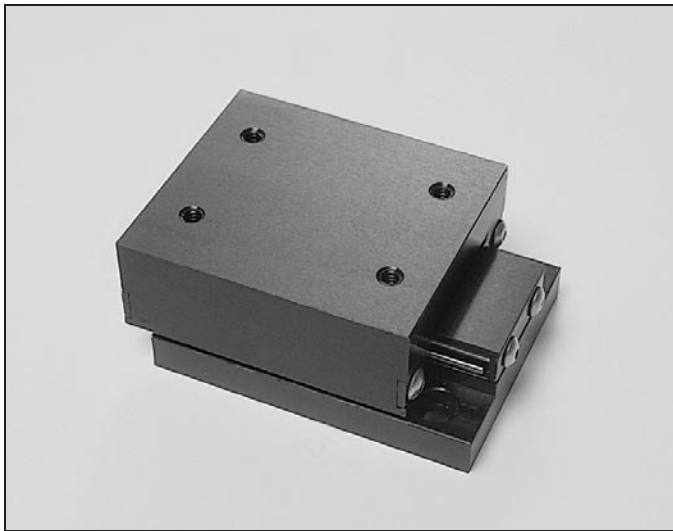

High Precision Series Ball Slides (Flange Base)

SPECIFICATIONS:

Straight Line Accuracy
0.000040"/" of travel.

Repeatability
0.000020".

Coefficient of Friction
0.002.

Finish
Black Anodize. Other finishes on request.

Construction

Aluminum carriage and base. Hardened 400 series stainless steel balls, shafts, pre-load gibs. Interchangeable with other manufacturers. Carriage and base ground to optical flatness. Bearing way surfaces held to submicron tolerances. Carriage surface flat to 0.0001"/". Flange Base design allows ease of mounting and stability.

HPM SERIES ONLY

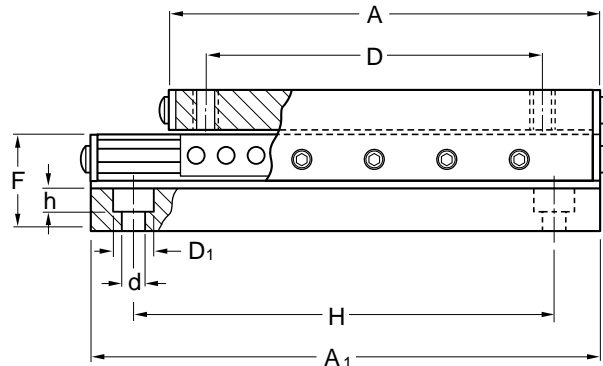
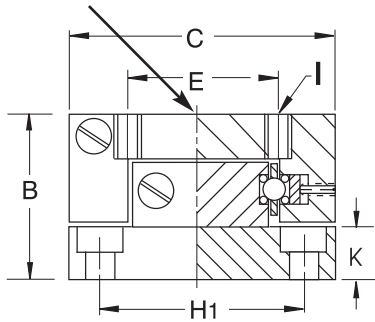

moment load ratings + load / life formulas. pg 96

*Travel is 1/2 distance from center in either direction.

Model	LOAD CAPACITY																
	Travel* (in.)	Lbs.	Weight (lbs.)	A	A ₁	B	C	D	d	D ₁	E	F	H ₁	H	h	I	K
HPM-1FB	0.5	8	0.08	1.00	1.25			0.625						0.750			
HPM-2FB	1.0	15	0.14	1.75	2.00	.750	1.00	1.375	.125	.198	CL	0.50	0.750	1.500	.125	#4-40	0.25
HPM-2.5FB	1.5	25	0.20	2.50	2.75			2.125						2.250			
HPM-3FB	2.0	30	0.26	3.25	3.50			2.875						3.000			
HPS2-1FB	1.0	25	0.38	2.00	2.25			1.375						1.625			
HPS2-1.5FB	1.5	31	0.52	2.75	3.00	1.031	1.75	2.125	.157	.240	0.875	0.68	1.312	2.250	.145	#6-32	0.28
HPS2-2FB	2.0	42	0.61	3.25	3.50			2.625						2.750			
HPS2-3FB	3.0	51	0.75	4.00	4.25			3.375						3.500			
HPS3-1FB	1.0	72	0.91	2.62	2.62			2.125						2.125			
HPS3-2FB	2.0	84	1.40	4.00	4.37			3.000						3.375			
HPS3-3FB	3.0	102	1.75	5.00	5.37	1.375	2.62	4.000	.204	.328	1.250	1.00	2.062	4.375	.205	#10-32	0.37
HPS3-4FB	4.0	132	2.10	6.00	6.37			5.000						5.375			
HPS3-5FB	5.0	145	2.80	8.00	8.37			7.000						7.375			
HPS4-2FB	2.0	130	2.50	4.00	4.50			2.000						2.500			
HPS4-3FB	3.0	140	3.59	5.75	6.25			3.750						4.250			
HPS4-5FB	5.0	160	5.00	8.00	8.50	1.750	3.50	6.000	.204	.328	2.000	0.99	2.750	6.500	.205	#10-32	0.37
HPS4-6.5FB	6.5	175	6.41	10.25	10.75			8.250						8.750			
HPS4-9FB	9.0	200	8.75	14.00	14.50			12.000						12.500			
HPS5-5FB	5.0	150	12.00	8.25	8.75			6.250						6.250			
HPS5-7FB	7.0	180	17.40	12.00	12.50	2.375	5.75	10.000	.281	.412	4.000	1.35	5.000	10.000	.280	1/4-20	0.37
HPS5-10FB	10.0	225	21.76	15.00	15.50			13.000						13.000			



High Precision Series Crossed Roller Slides (Low Profile)

SPECIFICATIONS:

Straight Line Accuracy
0.000040"/" of travel.

Repeatability
0.000020".

Coefficient of Friction
0.002.

Finish
Black Anodize. Other finishes on request.

Construction

Aluminum carriage and base. Hardened 400 series stainless steel rollers, shafts, pre-load gibs. Interchangeable with other manufacturers. Carriage and base ground to optical flatness. Bearing way surfaces held to submicron tolerances. Carriage surface flat to 0.0001"/". Crossed Roller design greatly increases load capacity and overhung load capability.

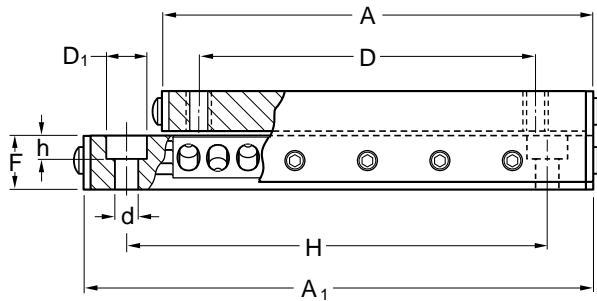
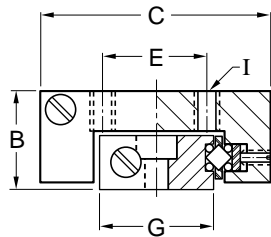

moment load ratings + load / life formulas. pg. 96

*Travel is 1/2 distance from center in either direction.																
Model	LOAD CAPACITY			A	A ₁	B	C	D	d	D ₁	E	F	G	H	h	I
	Travel* (in.)	Lbs.	Weight (lbs.)													
HPRS2-1	1.0	90	0.28	2.00	2.25			1.375						1.625		
HPRS2-1.5	1.5	115	0.38	2.75	3.00	.750	1.75	2.125	.157	.244	0.875	0.40	0.87	2.250	.145	#6-32
HPRS2-2	2.0	130	0.46	3.25	3.50			2.625						2.750		
HPRS2-3	3.0	140	0.56	4.00	4.25			3.375						3.500		
HPRS3-1	1.0	220	0.66	2.62	2.62			2.125						2.125		
HPRS3-2	2.0	250	1.00	4.00	4.37	1.000	2.62	3.000	.204	.328	1.250	0.62	1.50	3.375	.205	#10-32
HPRS3-3	3.0	350	1.25	5.00	5.37			4.000						4.375		
HPRS3-4	4.0	390	1.50	6.00	6.37			5.000						5.375		
HPRS3-5	5.0	420	2.00	8.00	8.37			7.000						7.375		
HPRS4-2	2.0	260	2.00	4.00	4.50			2.000						2.500		
HPRS4-3	3.0	280	2.88	5.75	6.25	1.375	3.50	3.750	.204	.328	2.000	0.62	1.98	4.250	.205	#10-32
HPRS4-5	5.0	320	4.00	8.00	8.50			6.000						6.500		
HPRS4-6.5	6.5	350	5.13	10.25	10.75			8.250						8.750		
HPRS4-9	9.0	400	7.00	14.00	14.50			12.000						12.500		
HPRS5-5	5.0	300	10.00	8.25	8.75			6.250						6.250		
HPRS5-7	7.0	360	14.52	12.00	12.50	2.000	5.75	10.000	.281	.412	4.000	0.98	3.70	10.000	.280	1/4-20
HPRS5-10	10.0	450	18.15	15.00	15.50			13.000						13.000		

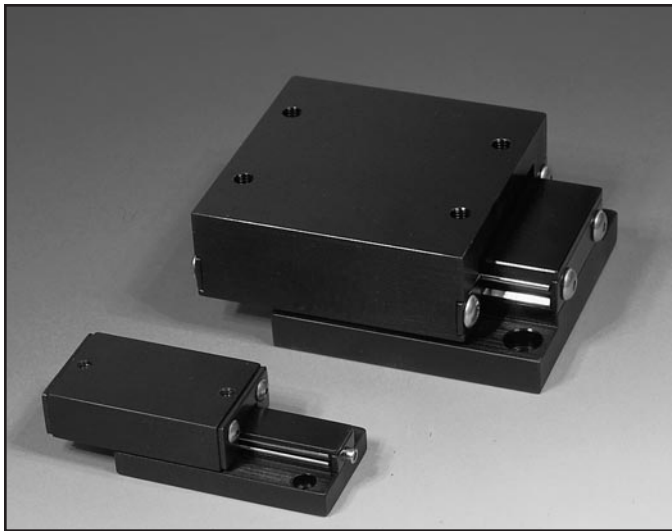

High Precision Series Crossed Roller Slides (Flange Base)

SPECIFICATIONS:

Straight Line Accuracy
0.000040"/" of travel.

Repeatability
0.000020".

Coefficient of Friction
0.002.

Finish
Black Anodize. Other finishes on request.

Construction

Aluminum carriage and base.
Hardened 400 series stainless steel rollers, shafts, pre-load gibs.
Interchangeable with other manufacturers. Carriage and base ground to optical flatness. Bearing way surfaces held to submicron tolerances. Carriage surface flat to 0.0001"/". Flange Base with crossed roller design offers the ultimate in accuracy, capacity and stability.

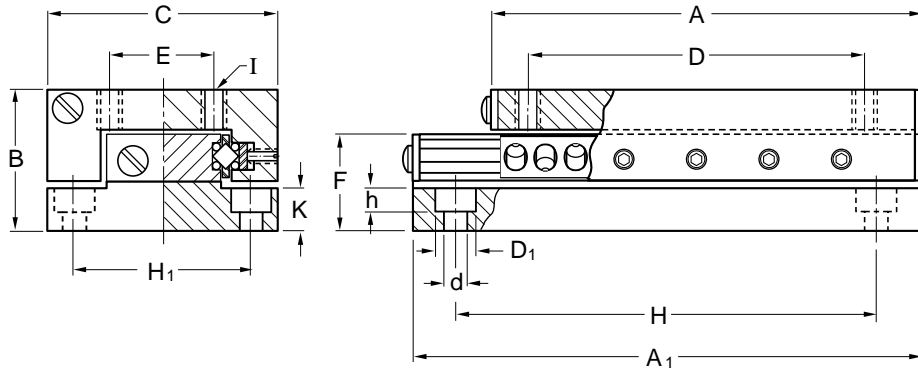

moment load ratings + load / life formulas. pg. 96

*Travel is 1/2 distance from center in either direction.

Model	Travel* (in.)	LOAD CAPACITY		A	A ₁	B	C	D	d	D ₁	E	F	H ₁	H	h	I	K	
		Lbs.	Weight (lbs.)															
HPRS2-1FB	1.0	90	0.38	2.00	2.25			1.375						1.625				
HPRS2-1.5FB	1.5	115	0.52	2.75	3.00	1.031	1.75	2.125	.157	.240	0.875	0.68	1.312	2.250	.145	#6-32	0.28	
HPRS2-2FB	2.0	130	0.61	3.25	3.50			2.625						2.750				
HPRS2-3FB	3.0	140	0.75	4.00	4.25			3.375						3.500				
HPRS3-1FB	1.0	220	0.91	2.62	2.62			2.125						2.125				
HPRS3-2FB	2.0	250	1.40	4.00	4.37	1.375	2.62	3.000	.204	.328	1.250	1.00	2.062	3.375	.205	#10-32	0.37	
HPRS3-3FB	3.0	350	1.75	5.00	5.37			4.000						4.375				
HPRS3-4FB	4.0	390	2.10	6.00	6.37			5.000						5.375				
HPRS3-5FB	5.0	420	2.80	8.00	8.37			7.000						7.375				
HPRS4-2FB	2.0	260	2.50	4.00	4.50			2.000						2.500				
HPRS4-3FB	3.0	280	3.59	5.75	6.25	1.750	3.50	3.750	.204	.328	2.000	.99	2.750	4.250	.205	#10-32	0.37	
HPRS4-5FB	5.0	320	5.00	8.00	8.50			6.000						6.500				
HPRS4-6.5FB	6.5	350	6.41	10.25	10.75			8.250						8.750				
HPRS4-9FB	9.0	400	8.75	14.00	14.50			12.000						12.500				
HPRS5-5FB	5.0	300	12.00	8.25	8.75			6.250						6.250				
HPRS5-7FB	7.0	360	17.40	12.00	12.50	2.375	5.75	10.000	.281	.412	4.000	1.35	5.000	10.000	.280	1/4-20	0.37	
HPRS5-10FB	10.0	450	21.76	15.00	15.50			13.000						13.000				

Mini Posi-Drive™ Stages

6 Reasons to choose Del-Tron® Mini Posi-Drive™ Stages (LS1, LRS1 Series)

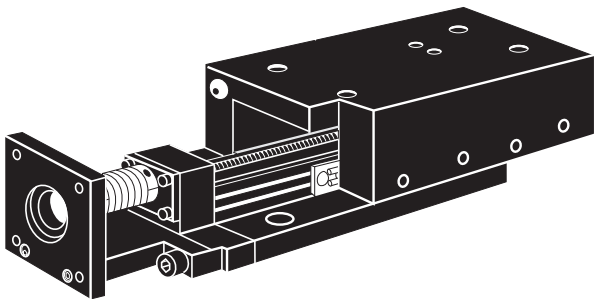

1. Positive lead screw drive.
2. Zero backlash.
3. Friction-free linear ball or roller slides.
4. Accurate, repeatable linear travel.
5. Compact adaptable configuration.
6. Adaptable to standard Nema Configurations.

Del-Tron® Mini Posi-Drive™ Stages

Compact Posi-Drive™ series LS1 and LRS1 stages have a height of only 1.250 inch and a width of only 1.380 inch. These stages provide the same outstanding 0.0001 inch straight line accuracy per inch of travel and 0.0001 inch repeatability as the larger LS3 series Posi-Drive™ line. The new smaller stages also offer a compact, flexible configuration and are adaptable to standard Nema configurations.

The LS1 Posi-Drive™ stages offer a .168 inch diameter .125 lead screw, an anti-backlash nut and a flexible zero backlash coupling that accepts a Nema 14 motor. They provide a load-carrying capacity of up to 40 pounds. The stages are available in travel lengths ranging from 1 inch to 4 inches. Del-Tron also provides special configurations, motor mounts, hand crank actuation and a variety of leads and pitches.

The new positioners are available with either linear ball or crossed roller slides and can be configured for one, two, or three-axis positioning. In the ball slide version, precision steel balls roll in the raceway grooves with contact at four points, enabling load and moment to be carried on all directions. Rolling resistance is extremely low, ensuring smooth and stable operation. Crossed roller slides physically resemble ball slides except for the bearing design. The rollers share a larger contact surface with the rods as compared to the point contact of steel balls. This bearing design allows crossed roller slides to carry larger loads and absorb greater load impacts than equivalent size ball slides.

moment load ratings + load / life formulas. pg. 96

*Travel is 1/2 distance from center in either direction.

Ball Slide Mini Posi-Drive™	Travel*	A	B	C	D	H	L	S	Load Capacity LB
LS1-1-C125	1"	4.07	2.000	2.07	1.375	1.500	.310	1.190	8
LS1-2-C125	2"	5.07	3.000	2.07	2.375	2.500	.810	.690	10
LS1-3-C125	3"	6.07	4.000	2.07	3.375	3.500	1.310	.990	15
LS1-4-C125	4"	8.32	6.000	2.32	5.375	4.000	2.310	.990	20

Maximum Recommended
Revolutions Per Second

Lead: .024", .050", .096"	20 RPS
Lead: .125", .188", .250", .375"	10 RPS

moment load ratings + load / life formulas. pg. 96

*Travel is 1/2 distance from center in either direction.

Roller Slide Mini Posi-Drive™	Travel*	A	B	C	D	H	L	S	Load Capacity LB
LRS1-1-C125	1"	4.07	2.000	2.07	1.375	1.500	.310	1.190	15
LRS1-2-C125	2"	5.07	3.000	2.07	2.375	2.500	.810	.690	20
LRS1-3-C125	3"	6.07	4.000	2.07	3.375	3.500	1.310	.990	30
LRS1-4-C125	4"	8.32	6.000	2.32	5.375	4.000	2.310	.990	40

Mini Posi-Drive™ Series LS1, LRS1

Designed for NEMA 14 motor frame, other motor adaptors available. Supplied with coupling for .1968" (5mm) motor shaft.
 Couplings with inch and metric bore available. Uses .168" diameter leadscrew with anti-backlash nut. Standard lead is .125".
 Leads available at no additional cost .024", .050", .096", .188", .250", and .375". Standard travels of 1, 2, 3, and 4"

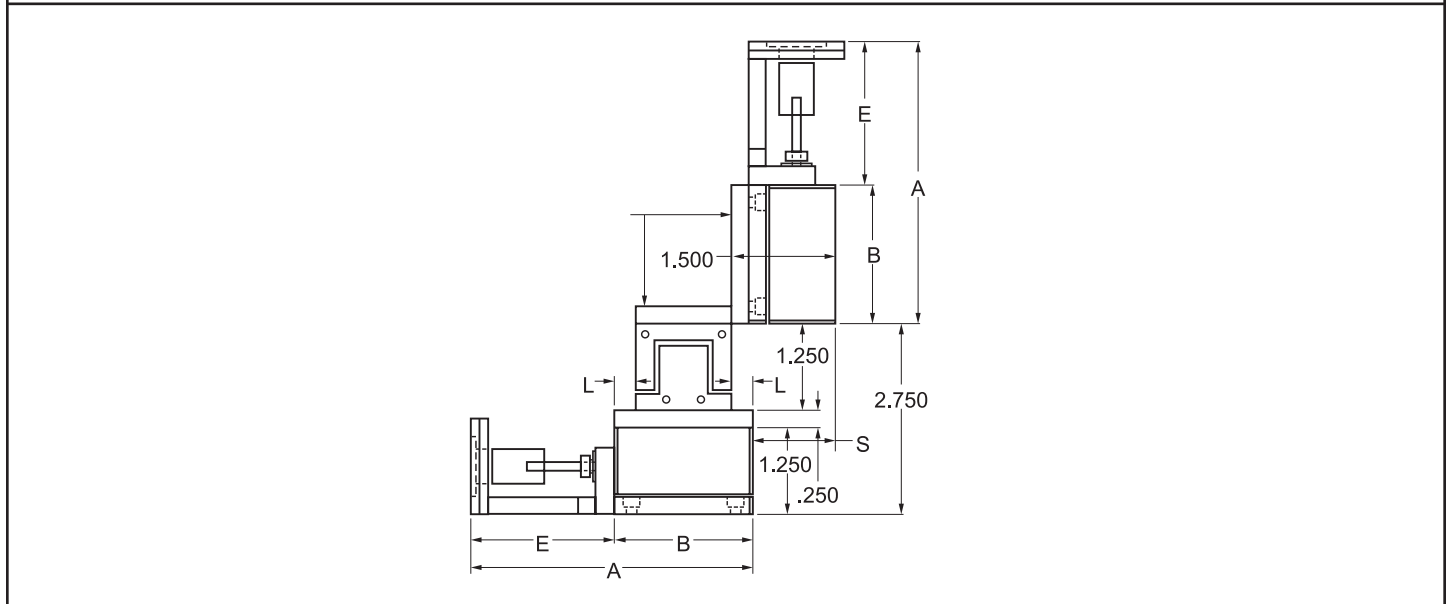
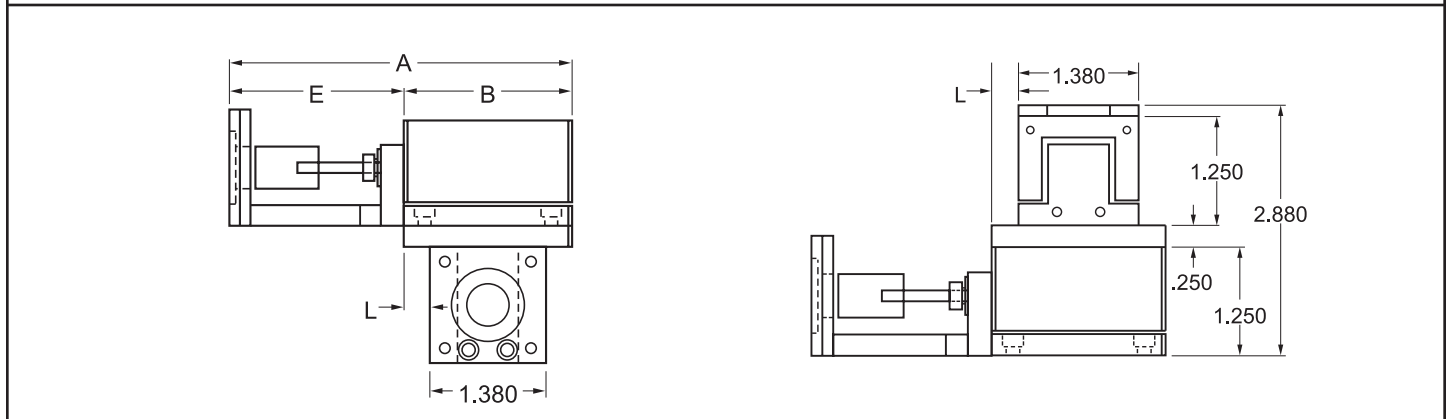
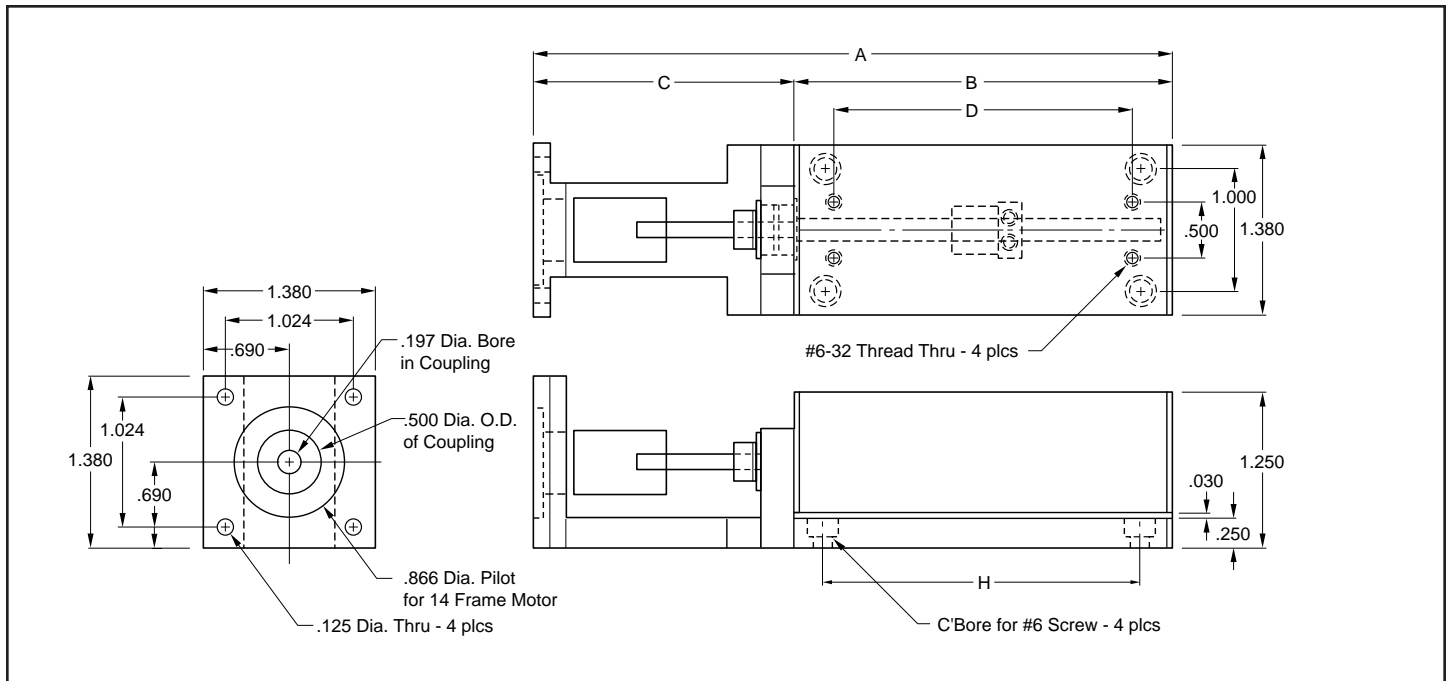

LIMIT AND POSITION SWITCHES

EOT (End Of Travel) and HPS (Home Position Switches)

Del-Tron Precision offers the addition of EOT and HPS to all 3 sizes of the Posi-Drive series. The EOT kit and the HPS kit could be used together or independently. The stand alone kits can be added to any of the 3 sizes of the Posi-Drive series. The EOT kit comes with 2 switches mounted to the base at each end. There are 2 flags that are mounted to the carriage. These flags are adjustable for either the full range of travel or for limited amount of travel if the application requires such. The Home Position Switch kit comes with 1 switch mounted to the base in the center. There is an adjustable flag mounted to the carriage. The adjustable flag will allow the Home Position to be set anywhere along the entire range of travel. The EOT and HPS are easily mounted to brackets, which are then attached to the base. The flags are easily assembled to a bracket that is then attached to the carriage. The base and carriage have the threaded mounting holes available for easy assembly of the brackets. The switches are photoelectric sensors that operate on a supply voltage of 5 to 24 VDC. The repeatability is .0002" and the response time is 100μseconds. The sensors are available in both NPN and PNP outputs. The sensors are equipped with a quick fitting Hook-Up Connector with cable lengths in 1m or 3m.

Part Numbering System for EOT and HPS

E-PNP-1
X-XXX-X

X-Configuration- E=EOT, H=HPS, EH=Combined
XXX=Type of Sensor, PNP or NPN
X=Length of Cable, 1=1meter, 3= 3 meter

Part Number

E-PNP-1
E-NPN-1
H-PNP-1
H-NPN-1
EH-PNP-1
EH-NPN-1

LS1 and LRS1 SERIES		
TRAVEL	B	J
1	2.000	1.500
2	3.000	2.500
3	4.000	3.500
4	6.000	5.500

Prices are the same for the 3 meter length cable and connector.

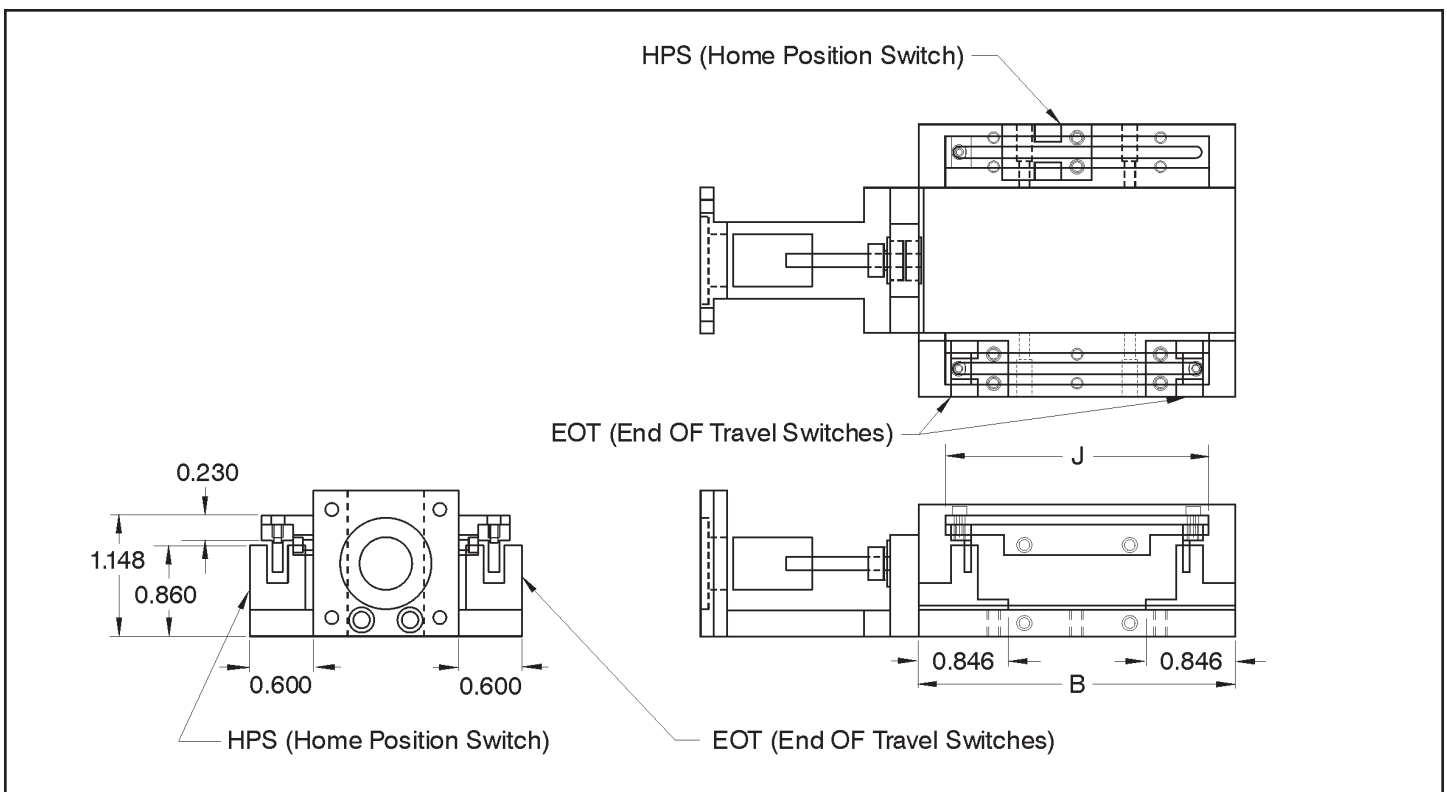

Mini Posi-Drive Stages

6 Reasons to choose Del-Tron[®] Mini Posi-Drive[™] Stages (LS2, LRS2 Series)

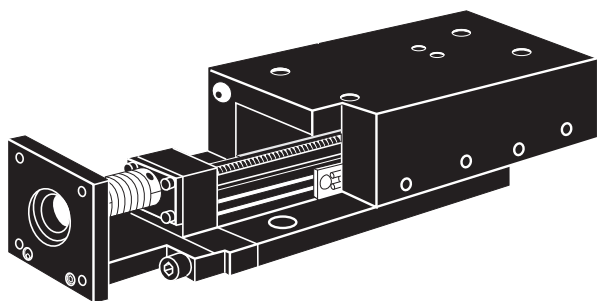

1. Positive lead screw drive.
2. Zero backlash.
3. Friction-free linear ball or roller slides.
4. Accurate, repeatable linear travel.
5. Compact adaptable configuration.
6. Adaptable to standard Nema Configurations.

Del-Tron[®] Mini Posi-Drive[™] Stages

Compact Posi-Drive[™] series LS2 and LRS2 stages have a height of only 1.650 inch and a width of only 1.750 inch. These stages provide the same outstanding 0.0001 inch straight line accuracy per inch of travel and 0.0001 inch repeatability as the larger LS3 series Posi-Drive[™] line. The new smaller stages also offer a compact, flexible configuration and are adaptable to standard Nema configurations.

The LS2 Posi-Drive[™] stages offer a 0.250 inch diameter .250 lead screw, an anti-backlash nut and a flexible zero backlash coupling that accepts a Nema 17 motor. They provide a load-carrying capacity of up to 60 pounds. The stages are available in travel lengths ranging from 1 inch to 4 inches. Del-Tron also provides special configurations, motor mounts, hand crank actuation and a variety of leads and pitches.

The new positioners are available with either linear ball or crossed roller slides and can be configured for one, two, or three-axis positioning. In the ball slide version, precision steel balls roll in the raceway grooves with contact at four points, enabling load and moment to be carried on all directions. Rolling resistance is extremely low, ensuring smooth and stable operation. Crossed roller slides physically resemble ball slides except for the bearing design. The rollers share a larger contact surface with the rods as compared to the point contact of steel balls. This bearing design allows crossed roller slides to carry larger loads and absorb greater load impacts than equivalent size ball slides.



Del-Tron® Mini Posi-Drive™ Stages

Specifications

- Drive:** .250 diameter .250 lead screw with anti-backlash nut.
- Coupling:** Flexible zero backlash coupling.
- Motor Mount:** Accepts Nema 17 motor
- Travel:** 1" - 4"
- Anti-Friction Slide:** Linear ball or crossed roller slide.
- Load Capacity:** Up to 60lbs.
- Configuration:** 1, 2 or 3 axis.
- Accuracy:** Straight line, up to 0.0001" per inch of travel.
- Repeatability:** 0.0001"
- Finish:** Black Anodize. Other finishes on request
- Also available are special configurations, motor mounts, hand crank actuation, and a variety of leads and diameters.

Nomenclature

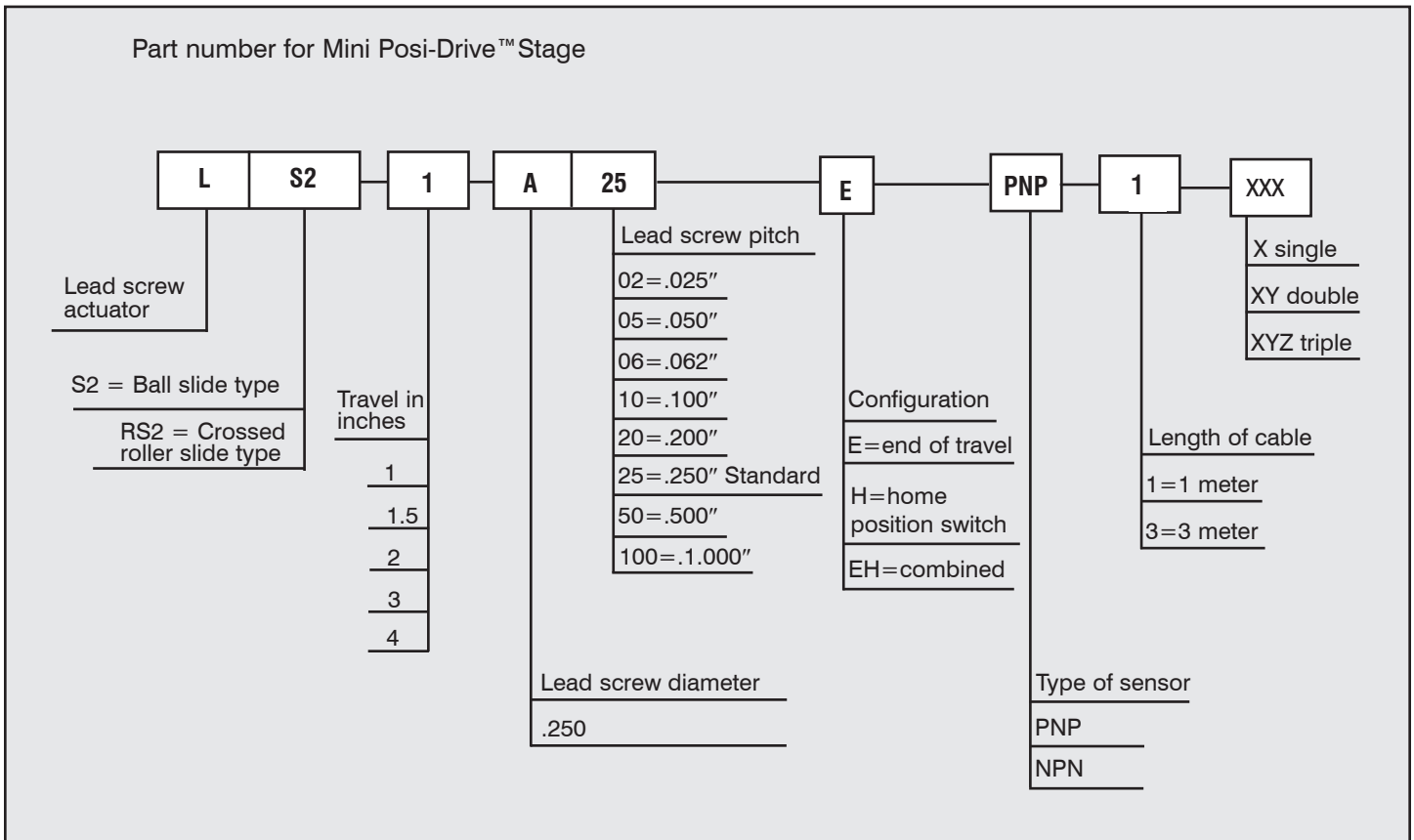

moment load ratings + load / life formulas. pg. 96

*Travel is 1/2 distance from center in either direction.

Ball Slide Mini Posi-Drive™	Travel*	A	B	D	H	L	S	Load Capacity LB
LS2-1-A25	1"	4.88	2.25	1.375	1.625	.250	1.650	10
LS2-1.5-A25	1.5"	5.63	3.00	2.125	2.250	.625	1.275	15
LS2-2-A25	2"	6.13	3.50	2.750	2.750	.875	1.025	20
LS2-3-A25	3"	6.88	4.25	3.375	3.500	1.250	.650	25
LS2-4-A25	4"	8.63	6.00	5.500	4.000	2.125	1.775	30

Maximum Recommended
Revolutions Per Second

Lead: .025", .050", .062", .100"	20 RPS
Lead: .200", .250", .500", 1.0"	10 RPS

moment load ratings + load / life formulas. pg. 96

*Travel is 1/2 distance from center in either direction.

Roller Slide Mini Posi-Drive™	Travel*	A	B	D	H	L	S	Load Capacity LB
LRS2-1-A25	1"	4.88	2.25	1.375	1.625	.250	1.650	20
LRS2-1.5-A25	1.5"	5.63	3.00	2.125	2.250	.625	1.275	30
LRS2-2-A25	2"	6.13	3.50	2.750	2.750	.875	1.025	40
LRS2-3-A25	3"	6.88	4.25	3.375	3.500	1.250	.650	50
LRS2-4-A25	4"	8.63	6.00	5.500	4.000	2.125	1.775	60

Mini Posi-Drive™ Series LS2, LRS2

Designed for NEMA 17 motor frame, other motor adaptors available. Supplied with coupling for 5mm motor shaft. Couplings with inch and metric bore available. Uses .250" diameter leadscrew with anti-backlash nut. Standard lead is .250". Leads available at no additional cost .025", .050", .062", .100", .200", .250", .500", and 1.00". Standard travels of 1, 1.5, 2, 3, and 4"

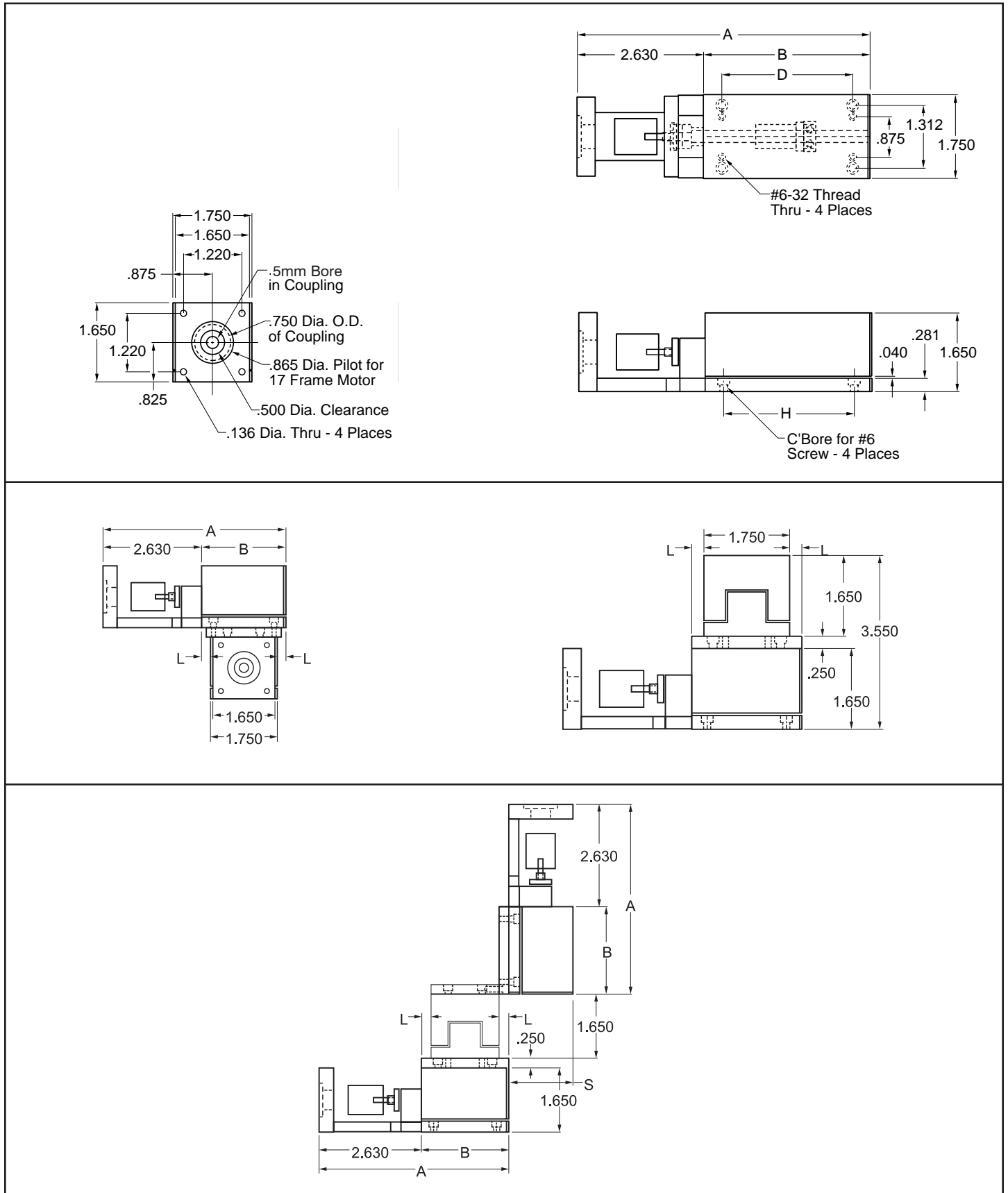

LIMIT AND POSITION SWITCHES

EOT (End Of Travel) and HPS (Home Position Switches)

Del-Tron Precision offers the addition of EOT and HPS to all 3 sizes of the Posi-Drive series. The EOT kit and the HPS kit could be used together or independently. The stand alone kits can be added to any of the 3 sizes of the Posi-Drive series. The EOT kit comes with 2 switches mounted to the base at each end. There are 2 flags that are mounted to the carriage. These flags are adjustable for either the full range of travel or for limited amount of travel if the application requires such. The Home Position Switch kit comes with 1 switch mounted to the base in the center. There is an adjustable flag mounted to the carriage. The adjustable flag will allow the Home Position to be set anywhere along the entire range of travel. The EOT and HPS are easily mounted to brackets, which are then attached to the base. The flags are easily assembled to a bracket that is then attached to the carriage. The base and carriage have the threaded mounting holes available for easy assembly of the brackets. The switches are photoelectric sensors that operate on a supply voltage of 5 to 24 VDC. The repeatability is .0002" and the response time is 100μseconds. The sensors are available in both NPN and PNP outputs. The sensors are equipped with a quick fitting Hook-Up Connector with cable lengths in 1m or 3m.

Part Numbering System for EOT and HPS

E-PNP-1
X-XXX-X

X-Configuration- E=EOT, H=HPS, EH=Combined
XXX=Type of Sensor, PNP or NPN
X=Length of Cable, 1=1meter, 3= 3 meter

Part Number

E-PNP-1
E-NPN-1
H-PNP-1
H-NPN-1
EH-PNP-1
EH-NPN-1

LS2 and LRS2 SERIES		
TRAVEL	B	J
1	2.250	1.625
1.5	3.000	2.375
2	3.500	2.875
3	4.250	3.625
4	6.000	5.375

Prices are the same for the 3 meter length cable and connector.

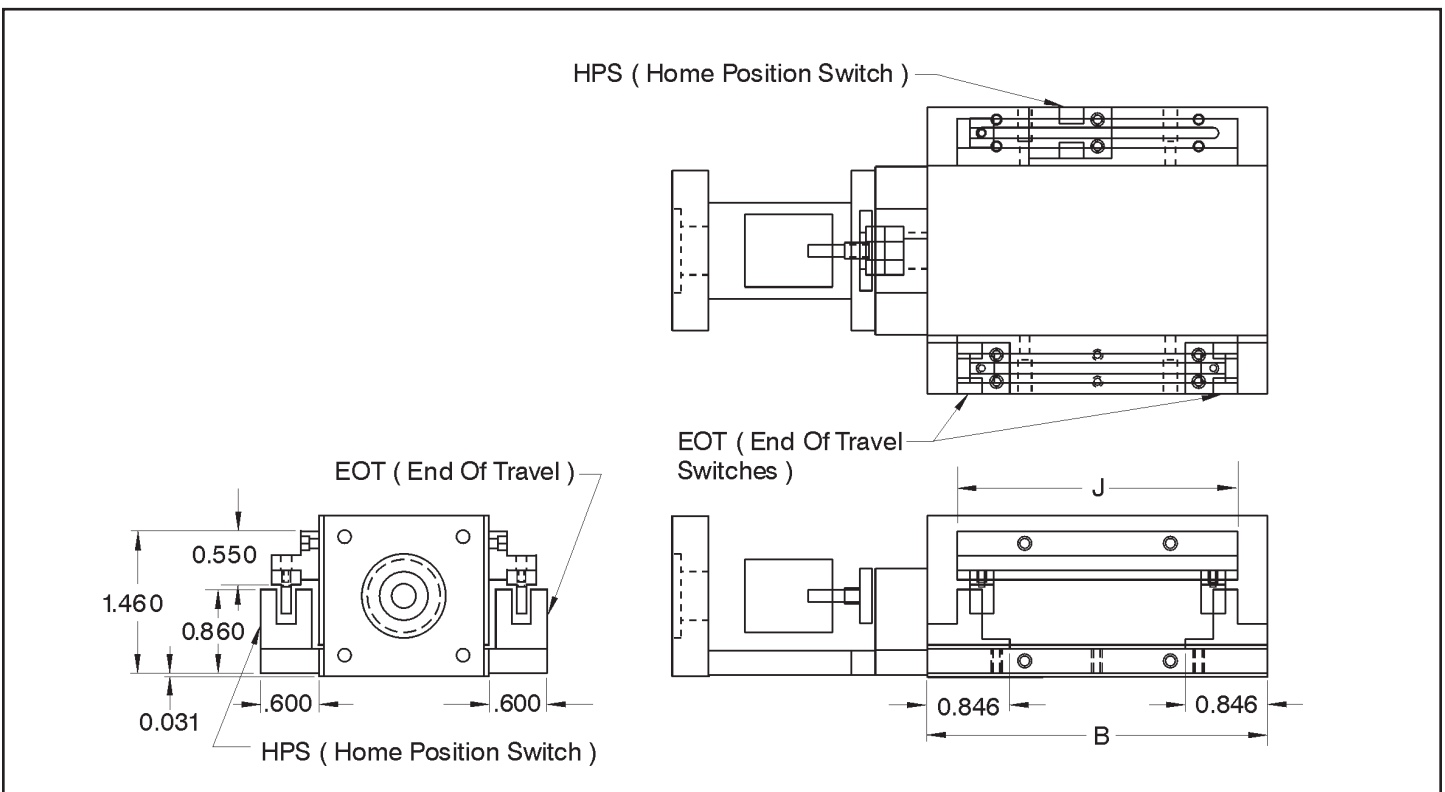

Posi-Drive™ Stages

6 Reasons to choose Del-Tron® Posi-Drive™ Stages

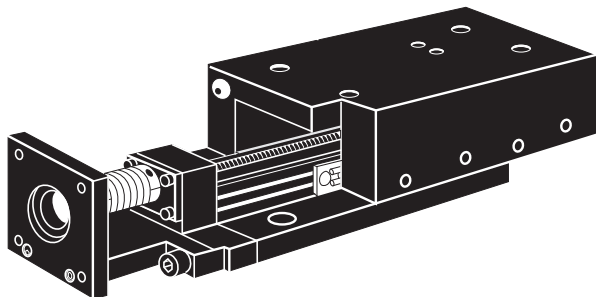

1. Positive lead screw drive.
2. Zero backlash.
3. Friction-free linear ball or roller slides.
4. Accurate, repeatable linear travel.
5. Compact adaptable configuration.
6. Adaptable to standard Nema Configurations.

Del-Tron® Posi-Drive™ Stages

Compact, economical Posi-Drive™ stages from Del-Tron take the work out of designing motion control systems.

Our stages require no alignment of components, install with only four standard fasteners, are fitted with anti-backlash lead screws, multi-beam couplings with high speed misalignment capability and standard NEMA motor mounts.

Available in one, two or three axis configurations with either ball or crossed roller slides, these stages travel up to 12". The crossed roller slide option increases load capacity up to 180 lbs. and 100 million inches of travel is possible at 1/2 rated load.

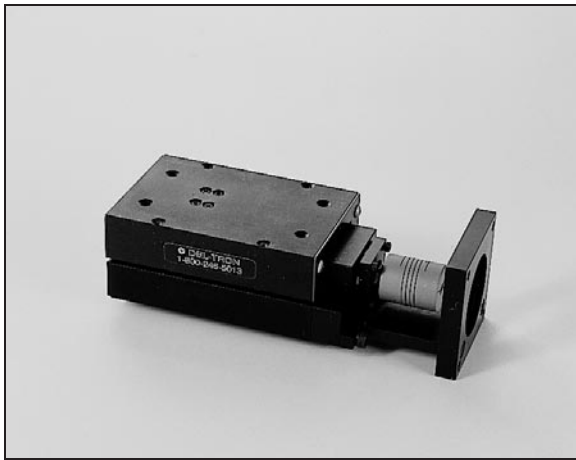

Del-Tron[®] Posi-Drive[™] Stages

Specifications

Drive: 3/8" diameter 0.10 lead screw with anti-backlash nut.

Coupling: Flexible zero backlash coupling.

Motor Mount: Accepts Nema 23 motor

Travel: 1" - 12"

Anti-Friction Slide: Linear ball or crossed roller slide.

Load Capacity: Up to 180lbs.

Configuration: 1, 2 or 3 axis.

Accuracy: Straight line, up to 0.0001" per inch of travel.

Repeatability: 0.0001"

Finish: Black Anodize. Other finishes on request

Also available are special configurations, motor mounts, and hand crank actuation. A variety of leads and diameters. Are available at no additional cost.

Nomenclature

Part number for Posi-Drive[™] Stage

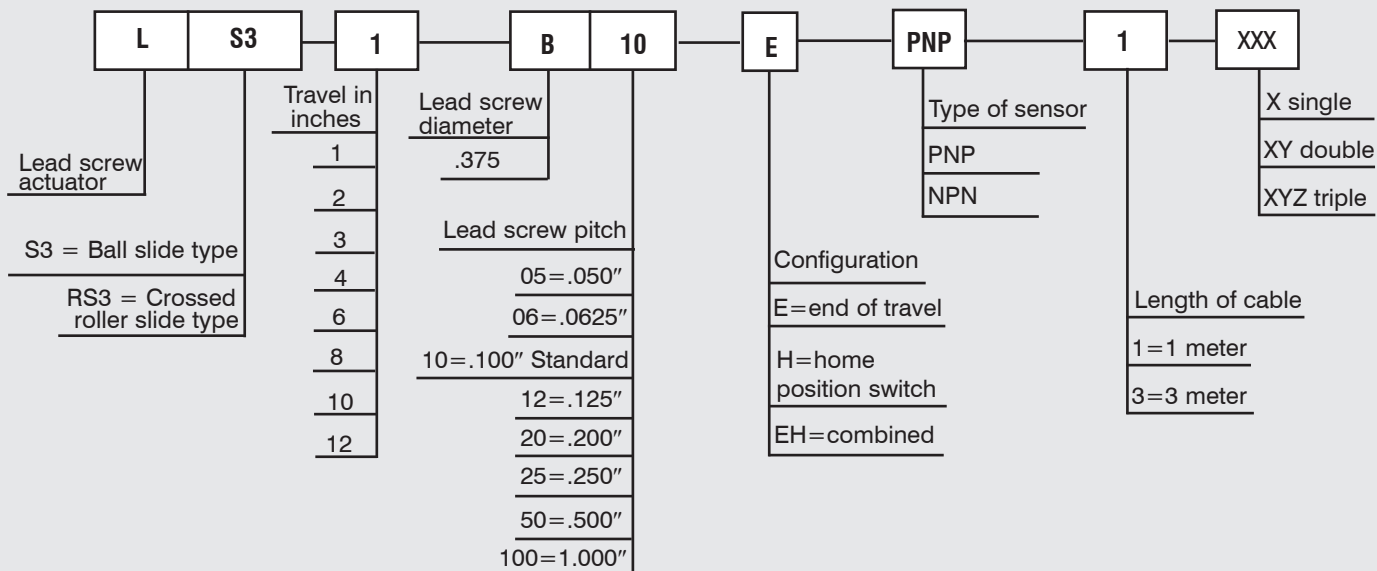

Designed for NEMA 23 motor frame. Supplied with coupling for 0.250" motor shaft.

Uses 3/8" diameter lead-screw with anti-backlash nut. Standard lead is 0.10".

Standard travels of 1" - 12"

Other motor adapters and coupling with inch and metric bore available as special order.

Leads available in 0.050", 0.0625", 0.100", 0.125", 0.200", 0.250", 0.500", 1.000" and 1.250"

Posi-Drive™																
MODEL	A	B	D	P	E	F	G	H	H1	J	K	L	M	N	R	S
LS3-1-B10	5.63	3.00	2.125		2.63	0.44	0.50	2.375	0	0.00	0.31	0.188	0	3.731	0.32	2.06
LS3-2-B10	6.63	4.00	3.000		2.63	0.50	1.00	2.375	3.375	0.31	0.82	0.688	0	3.731	0.32	1.56
LS3-3-B10	7.63	5.00	4.000		2.63	0.50	1.50	2.375	4.375	0.31	1.31	1.188	0	3.731	0.32	1.06
LS3-4-B10	8.63	6.00	5.000		2.63	0.50	2.00	2.375	5.375	0.31	1.81	1.688	0	3.731	0.75	0.56
LS3-6-B10	12.63	9.00		10	3.63	1.50	3.50	4.000	7.000	1.00	2.50	3.188	0.375	4.106	1.75	-0.94
LS3-8-B10	15.63	11.00		12	4.63	1.00	4.50	6.000	9.000	1.00	2.50	4.188	0.375	4.106	2.75	-1.94
LS3-10-B10	18.63	13.00		14	5.63	0.50	5.50	8.000	11.000	1.00	2.50	5.188	0.375	4.106	3.75	-2.94
LS3-12-B10	21.63	15.00		14	6.63	1.50	6.50	10.000	13.000	1.00	2.50	6.188	0.375	4.106	4.75	-3.94
<hr/>																
LRS3-1-B10	5.63	3.00	2.125		2.63	0.44	0.50	2.3750	0	0.00	0.31	0.188	0	3.731	0.32	2.06
LRS3-2-B10	6.63	4.00	3.000		2.63	0.50	1.00	2.3750	3.375	0.31	0.82	0.688	0	3.731	0.32	1.56
LRS3-3-B10	7.63	5.00	4.000		2.63	0.50	1.50	2.3750	4.375	0.31	1.31	1.188	0	3.731	0.32	1.06
LRS3-4-B10	8.63	6.00	5.000		2.63	0.50	2.00	2.3750	5.375	0.31	1.81	1.688	0	3.731	0.75	0.56
LRS3-6-B10	12.63	9.00		10	3.63	1.50	3.50	4.0000	7.000	1.00	2.50	3.188	0.375	4.106	1.75	-0.94
LRS3-8-B10	15.63	11.00		12	4.63	1.00	4.50	6.0000	9.000	1.00	2.50	4.188	0.375	4.106	2.75	-1.94
LRS3-10-B10	18.63	13.00		14	5.63	0.50	5.50	8.0000	11.000	1.00	2.50	5.188	0.375	4.106	3.75	-2.94
LRS3-12-B10	21.63	15.00		14	6.63	1.50	6.50	10.0000	13.000	1.00	2.50	6.188	0.375	4.106	4.75	-3.94

moment load ratings + load / life formulas. pg. 96

*Travel is 1/2 distance from center in either direction.

Maximum Recommended Revolutions Per Second	
Lead: .050", .0625", .100"	20 RPS
Lead: .125", .200", .250", .500", 1.0"	10 RPS

Posi-Drive™		
MODEL	TRAVEL* INCHES	LOAD CAPACITY
		LB.
LS3-1-B10	1	30
LS3-2-B10	2	35
LS3-3-B10	3	40
LS3-4-B10	4	45
LS3-6-B10	6	55
LS3-8-B10	8	60
LS3-10-B10	10	75
LS3-12-B10	12	90
<hr/>		
LRS3-1-B10	1	60
LRS3-2-B10	2	70
LRS3-3-B10	3	80
LRS3-4-B10	4	90
LRS3-6-B10	6	110
LRS3-8-B10	8	120
LRS3-10-B10	10	150
LRS3-12-B10	12	180

LIMIT AND POSITION SWITCHES

EOT (End Of Travel) and HPS (Home Position Switches)

Del-Tron Precision offers the addition of EOT and HPS to all 3 sizes of the Posi-Drive series. The EOT kit and the HPS kit could be used together or independently. The stand alone kits can be added to any of the 3 sizes of the Posi-Drive series. The EOT kit comes with 2 switches mounted to the base at each end. There are 2 flags that are mounted to the carriage. These flags are adjustable for either the full range of travel or for limited amount of travel if the application requires such. The Home Position Switch kit comes with 1 switch mounted to the base in the center. There is an adjustable flag mounted to the carriage. The adjustable flag will allow the Home Position to be set anywhere along the entire range of travel. The EOT and HPS are easily mounted to brackets, which are then attached to the base. The flags are easily assembled to a bracket that is then attached to the carriage. The base and carriage have the threaded mounting holes available for easy assembly of the brackets. The switches are photoelectric sensors that operate on a supply voltage of 5 to 24 VDC. The repeatability is .0002" and the response time is 100μseconds. The sensors are available in both NPN and PNP outputs. The sensors are equipped with a quick fitting Hook-Up Connector with cable lengths in 1m or 3m.

Part Numbering System for EOT and HPS

E-PNP-1
X-XXX-X

X-Configuration- E=EOT, H=HPS, EH=Combined
XXX=Type of Sensor, PNP or NPN
X=Length of Cable, 1=1meter, 3= 3 meter

Part Number

E-PNP-1
E-NPN-1
H-PNP-1
H-NPN-1
EH-PNP-1
EH-NPN-1

Prices are the same for the 3 meter length cable and connector.

LS3 and LRS3 SERIES		
TRAVEL	B	J
1	3.000	2.375
2	4.000	3.375
3	5.000	4.375
4	6.000	5.375
6	9.000	8.375
8	11.000	10.375
10	13.000	12.375
12	15.000	14.375

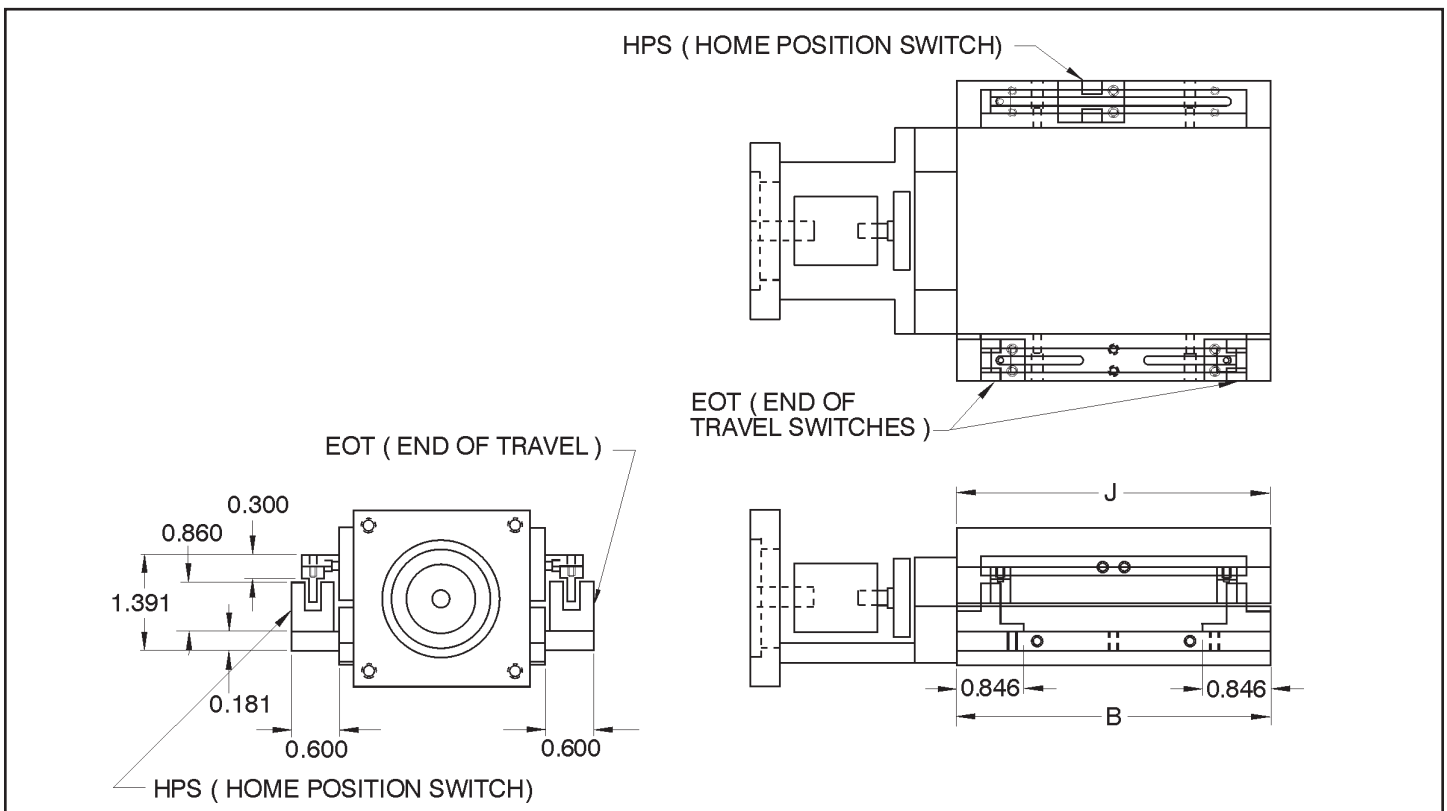

Friction Free Air Actuator

6 Reasons to choose Del-Tron® Air Actuators

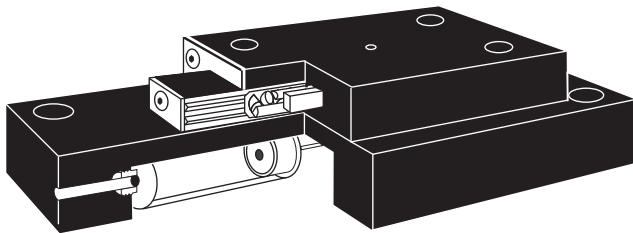

1. **Low Pressure operation: <10 PSI**
2. **Low Friction: <1gm**
3. **Wide range variable speed: smooth, slow and high speed capabilities.**
4. **Precise, gentle handling of wafers, chips and surface mount devices.**
5. **Ideal for fluid sample handling and adhesive deposition.**
6. **Del-Tron Crossed Roller Slide, driven by 2 Air Actuated Dashpots, provides a frictionless interface for up to 2" travel in a compact package.**

Del-Tron® Air Actuators

Pneumatically actuated crossed roller slide assemblies controlled by a pair of Airpot™ actuators, provide extremely low friction and stiction characteristics. A light touch or physical obstruction will stop the unit's movement to prevent damage to delicate and expensive equipment and parts. Low pressure operation is possible. The PNRE series requires less than 10 psi to operate.

Each slide is comprised of an aluminum carriage straddling an aluminum base. Using a bearing system containing cylindrical steel rollers, the carriage glides, almost friction-free, over the base. The rollers, alternately crisscrossed with each other, move between a set of four, partially flat, parallel, smooth rods on each side of the base. The Del-Tron® Straight Line Design™ makes possible the low stiction and friction characteristics Del-Trons are known for, unlike recirculating designs in which the rolling elements must turn corners and often slide against each other as they travel.

Airpot™ Pneumatic Actuators are ultra low friction devices designed to provide precise, repeatable motion at very high or low speeds without seals or lubrication. They run clean and operate over a wide temperature range with no change in performance. The basic construction consists of a graphitized carbon piston, precision ground to millionths of an inch TIR, inside an annealed, borosilicate glass cylinder with a precision fire polished bore.

Measurements in Inches

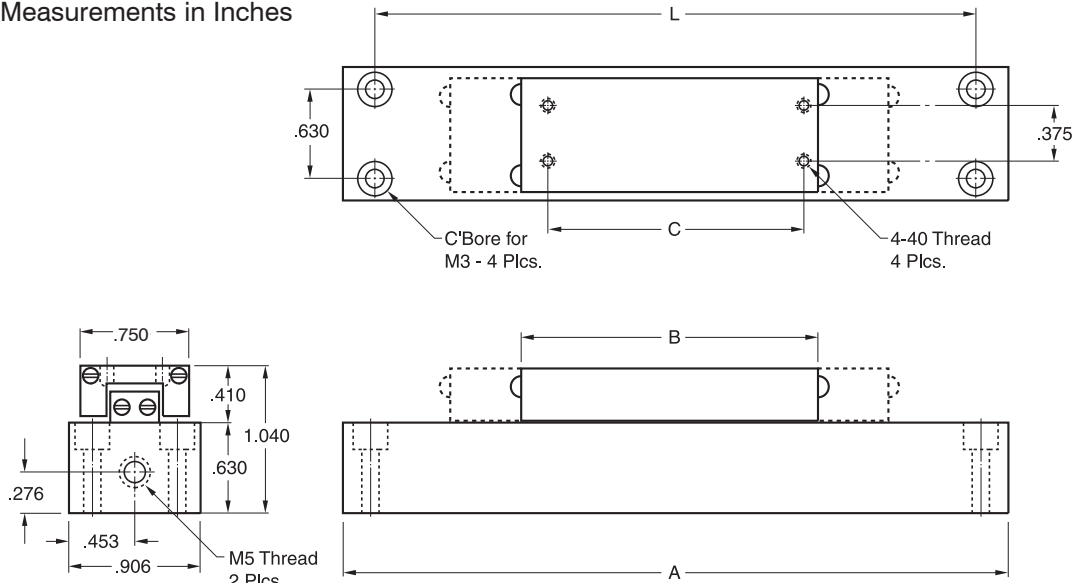

***Travel is 1/2 distance from center in either direction.**

MODEL	TRAVEL*	A	B	C	L	Load Capacity lbs.
PNRE-1	0.5	3.149	2.06	1.625	2.756	5
PNRE-2	1.0	4.724	2.06	1.625	4.331	5
PNRE-3	2.0	7.874	3.06	2.625	7.480	5

Measurements in Millimeters

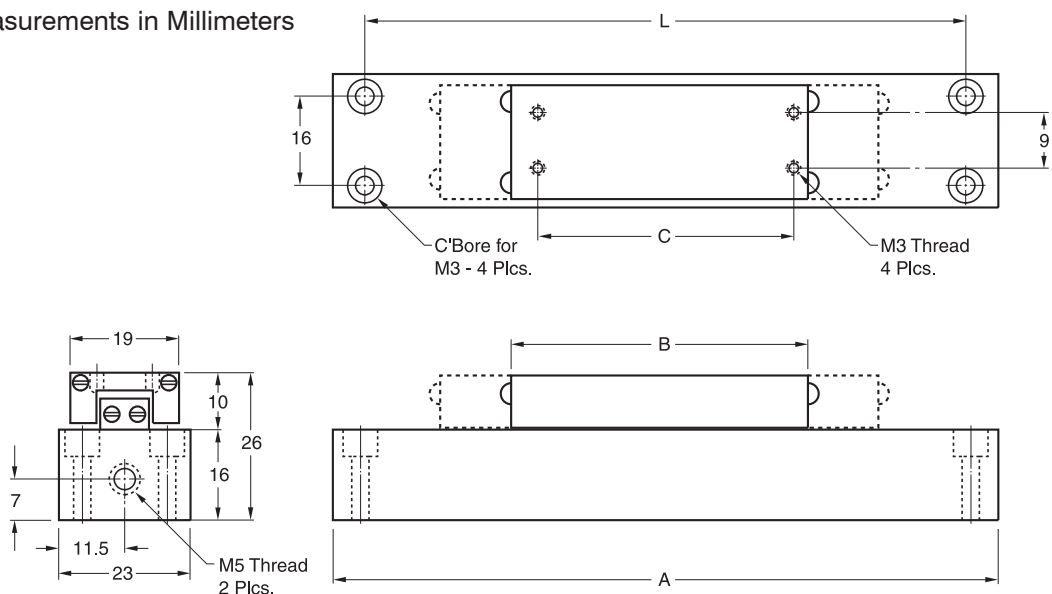

***Travel is 1/2 distance from center in either direction.**

MODEL	TRAVEL*	A	B	C	L	Load Capacity lbs.
PNRE-1M	12	80	54	41	70	5
PNRE-2M	25	120	54	41	110	5
PNRE-3M	50	200	78	66	190	5

Ball Slide Positioning Stages (Micrometer Driven)

6 Reasons to choose Del-Tron® Ball Slide Positioning Stages

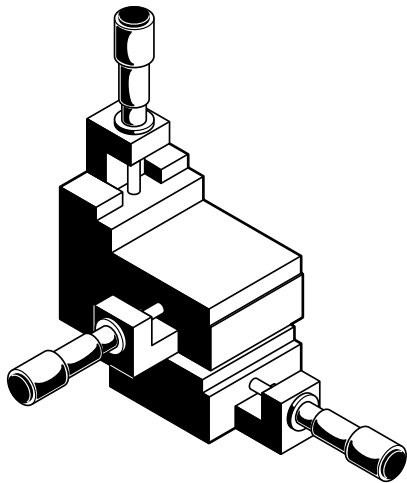

1. **Versatile-** Smooth, accurate travel for intermittent motion applications.
2. **Positive Locking-** Side mounted lock feature prevents movement of carriage.
3. **Accurate Measurements-** Carriages are spring loaded against micrometer heads with 0.001" (0.01mm) graduations.
4. **Adaptable-** One, two or three axis models can be used in any orientation.
5. **Easy To Use-** Standard counterbored holes in base and threaded holes in carriage.
6. **Wide Selection-** Subminiature and low profile models.

Del-Tron® Ball Slide Positioning Stages

Del-Tron offers over 60 models of positioning slides.

Used for gauging and positioning light and medium loads, applications include measuring instruments and optical assemblies. Del-Tron® positioners, built with the same rigorous manufacturing demands as our ball slide assemblies, offer the benefits of quality construction.

Spring loaded micrometer drives allow precise repeatable adjustments with low friction and zero backlash. (Micrometers available in inch or metric units.) Slides provide accuracy to .0005"/inch of travel and repeatability of .0001". Over 60 models support load capacities to 60 lb. Our full line includes the subminiature series with the smallest commercially available positioner, the standard series, ideal for most gauging and positioning applications, and our heavy duty series providing high load capacities with the same high accuracy and repeatability.

Positioning slides can be stacked for multi-axis applications. Standard stacked units are available in XY and XYZ configurations. Preloaded positioning slides, fully assembled, arrive ready for your use.

Positioners are available in black anodized finish or other finishes on request.

Nomenclature

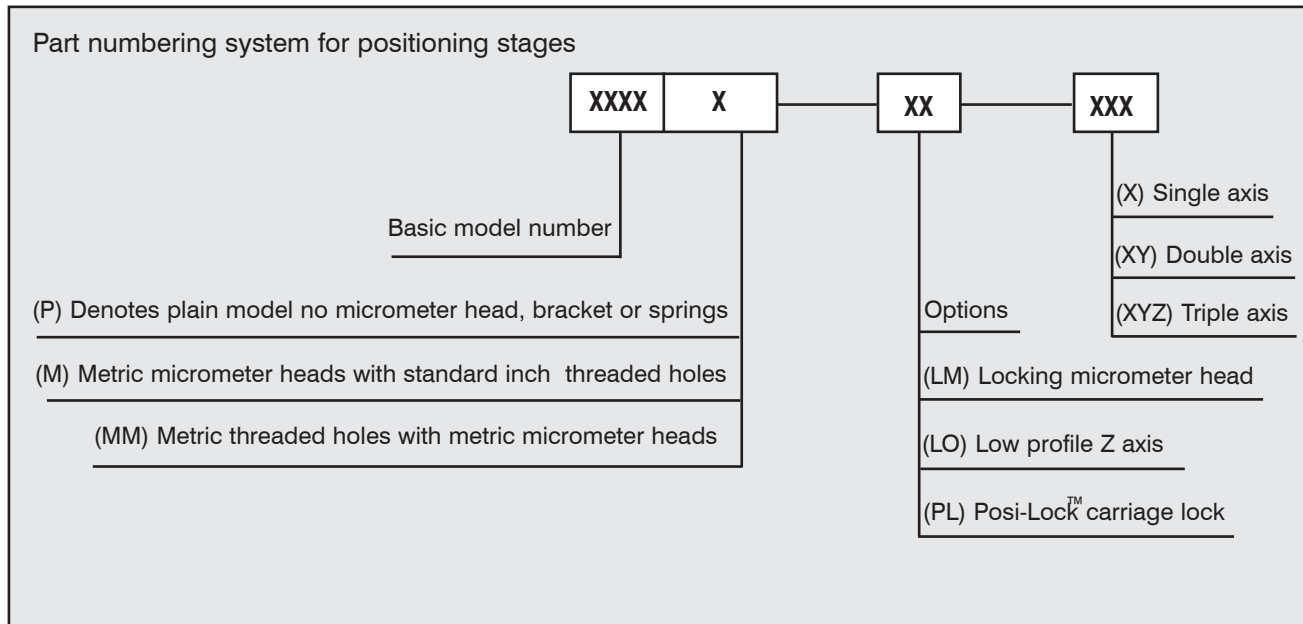

- Posi-Lock™ feature consists of steel shim and extended micrometer bracket secured by a screw mounted to the side of the stage carriage. This allows the user to positively lock the position of the carriage during use. Posi-Lock™ is standard on the model 99 and optional on all others.
- Locking micrometer heads are available to positively lock the micrometer setting. Not available for models 99, 101, 201, 301 and 2" (50mm) travel micrometers.
- Space saving side mount micrometer head style available. See page 53
- Loads in Z axis will extend springs if too heavy. Series 400, 500, 700, 1200, 2200 and 3200 have micrometer bracket reversed to prevent this and increase Z axis capacity
- Custom designs quoted on request.
- Metric threaded mounting holes optional at no additional cost.
- Metric Micrometer Heads available at no additional cost.
- (P) Plain Style are free floating slides without micrometer head, brackets or springs.
- (P-PL) Plain with Posi-Lock™ available, only on 1200, 2200, & 3200 series.

Ball Slide Positioning Stages

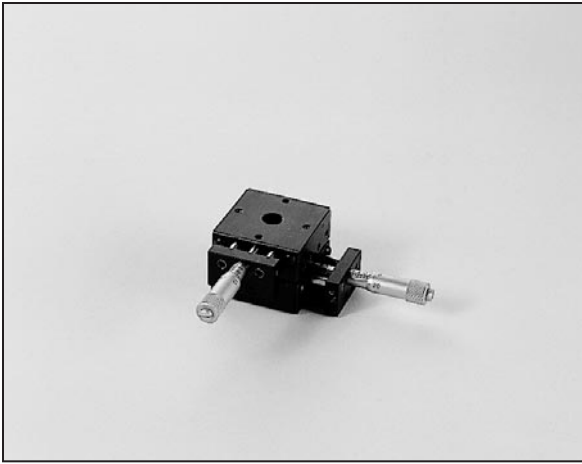

Specifications:

Straight Line Accuracy	.0005"/inch of travel
Repeatability	.0002"
Coefficient of Friction	0.003 typical
Drive	Micrometer, .001" graduations standard, .01 mm graduations optional
Construction	Aluminum carriage and base, hardened steel shafts and balls, mild steel endcaps
Finish	Black anodize standard; other finishes on request

moment load ratings + load / life formulas. pg. 97

*Travel is 1/2 distance from center in either direction.

MODEL	TRAVEL *	WORK SURFACE	OVERALL DIMENSIONS		LOAD CAPACITY, LB		THROUGH HOLE
		A X B	L	Hx	X, XY	Z	
99	.25 (6.4mm)	.75 X .75	2.28	.53	5	1.25	NO
101	.50 (13mm)	1.25 X 1.25	3.25	.38	4	1.25	NO
201	.50 (13mm)	1.75 X 1.75	3.75	.38	4	1.25	NO
301	.50 (13mm)	1.50 X 1.50	3.50	.62	12	2	.312 DIA.
450	.50 (13 mm)	1.75 X 1.75	4.38	.75	20	2	NO
451	1.00 (25 mm)	1.75 X 1.75	5.88	.75	20	2	NO
453	.50 (13 mm)	1.75 X 1.75	4.38	.75	20	2	.50 DIA.
750	.50 (13 mm)	2.62 X 2.62	5.25	1.00	60	2	NO
751	1.00 (25 mm)	2.62 X 2.62	6.75	1.00	60	2	NO
753	.50 (13 mm)	2.62 X 2.62	5.25	1.00	60	2	1.00 DIA.
401	.50 (13 mm)	2.00 X 1.75	4.62	.75	20	20	NO
501	.50 (13 mm)	3.25 X 1.75	5.86	.75	42	20	NO
502	1.00 (25 mm)	3.25 X 1.75	7.41	.75	42	20	NO
701	.50 (13 mm)	4.00 X 2.62	6.62	1.00	60	20	NO
702	1.00 (25 mm)	4.00 X 2.62	8.25	1.00	60	20	NO
1201	1.00 (25 mm)	3.12 X 3.12	7.25	.91	30	30	NO
1203	1.00 (25 mm)	3.12 X 3.12	7.25	.91	30	30	1.00 DIA.
2201	1.00 (25 mm)	4.12 X 4.12	8.25	.91	30	30	NO
2202	2.00 (50mm)	4.12 X 4.12	10.25	.91	30	30	NO
2203	1.00 (25 mm)	4.12 X 4.12	8.25	.91	30	30	1.50 DIA.
2204	2.00 (50mm)	4.12 X 4.12	10.25	.91	30	30	1.50 DIA.
3201	1.00 (25 mm)	5.12 X 5.12	9.25	.91	30	30	NO
3202	2.00(50mm)	5.12 X 5.12	11.25	.91	30	30	NO
3203	1.00 (25 mm)	5.12 X 5.12	9.25	.91	30	30	2.00 DIA.
3204	2.00(50mm)	5.12 X 5.12	11.25	.91	30	30	2.00 DIA.
PLAIN MODELS (WITHOUT MICROMETER, BRACKETS OR SPRINGS). X AND XY CONFIGURATIONS ONLY.							
101P	.50 (13mm)	1.25 X 1.25	—	.38	4	—	NO
201P	.50 (13mm)	1.75 X 1.75	—	.38	4	—	NO
301P	.50 (13mm)	1.50 X 1.50	—	.62	12	—	.312 DIA.
451P	1.00 (25mm)	1.75 X 1.75	—	.75	20	—	NO
452P	1.00 (25mm)	1.75 X 1.75	—	.75	20	—	.50 DIA.
751P	1.00 (25mm)	2.62 X 2.62	—	1.00	60	—	NO
752P	1.00 (25mm)	2.62 X 2.62	—	1.00	60	—	1.00 DIA.
1202P	2.00 (50mm)	3.12 X 3.12	—	.91	30	—	NO
1204P	2.00 (50mm)	3.12 X 3.12	—	.91	30	—	1.00 DIA.
2205P	3.00 (75mm)	4.12 X 4.12	—	.91	30	—	NO
2206P	3.00 (75mm)	4.12 X 4.12	—	.91	30	—	1.50 DIA.
3205P	4.00 (100mm)	5.12 X 5.12	—	.91	30	—	NO
3206P	4.00 (100mm)	5.12 X 5.12	—	.91	30	—	2.00 DIA.

inch (mm)

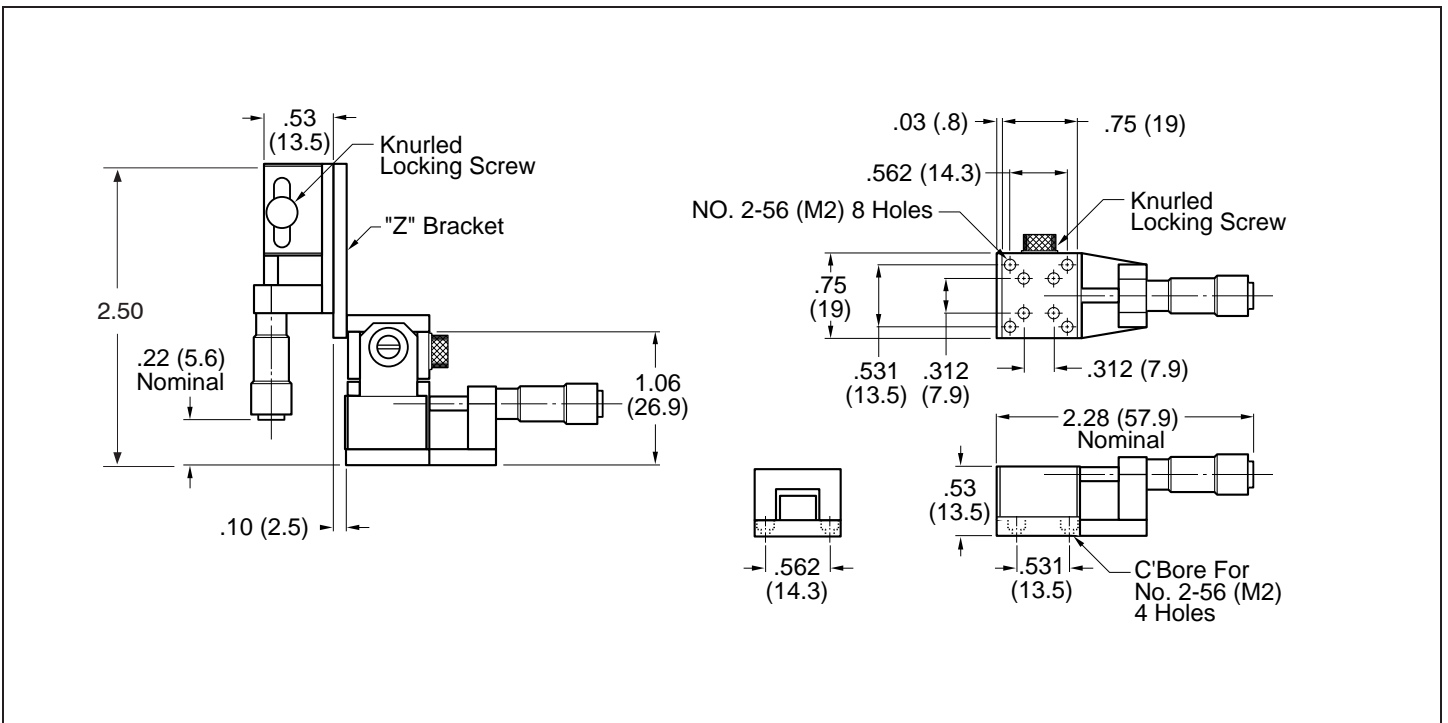

SERIES 99

Space saving side mount micrometer head style is available. See page 56

inch (mm)

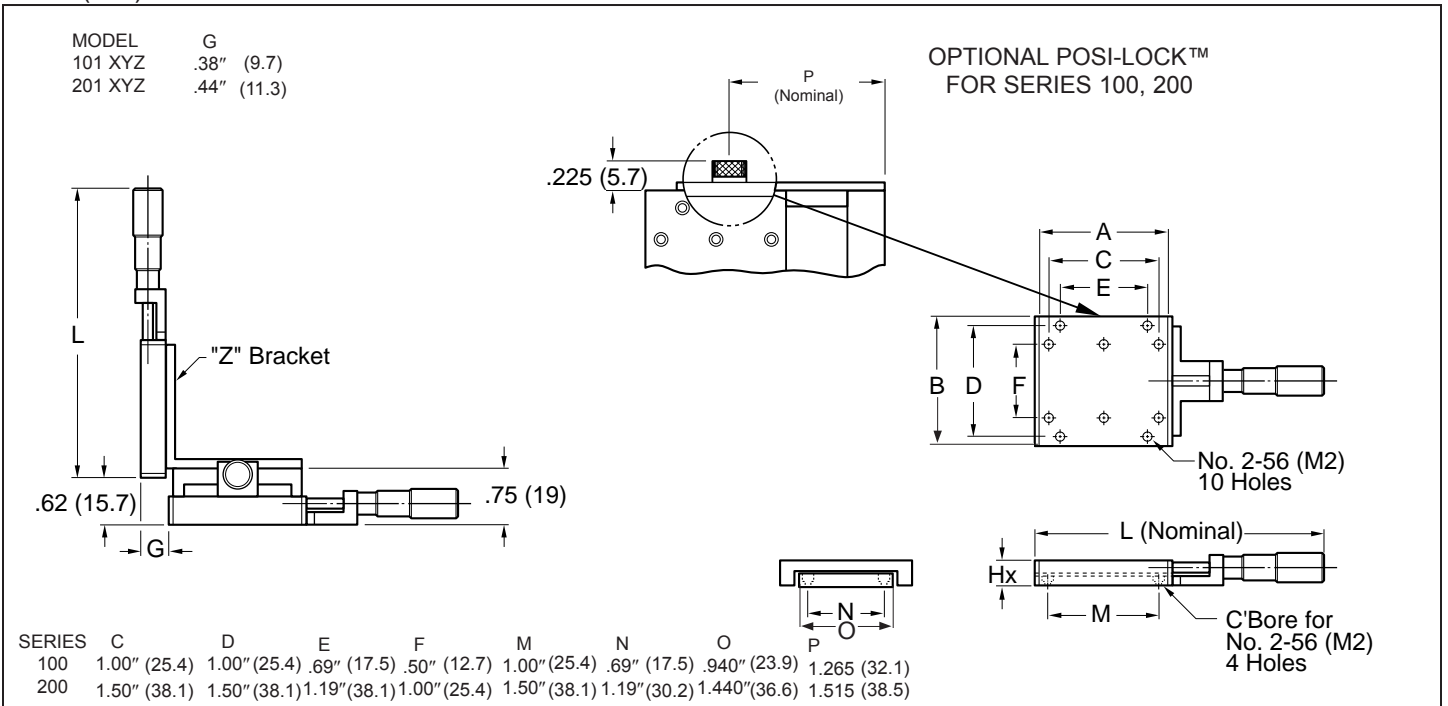

SERIES 100, 200

inch (mm)

SERIES	C	D	J	K	Hy
300	.44" (11.2)	1.00" (25.4)	1.62" (41.1)	.32" (8.1)	1.25" (31.8)
450	.69" (17.5)	1.12" (28.4)	2.00" (50.8)	—	1.50" (38.1)
750	.69" (17.5)	1.50" (38.1)	2.62" (66.5)	.06" (1.5)	2.00" (50.8)

SLOT

.38" (8) x .88" (22)
.50" (3) x 1.00" (25)
1.00" (25) x 1.50" (38)

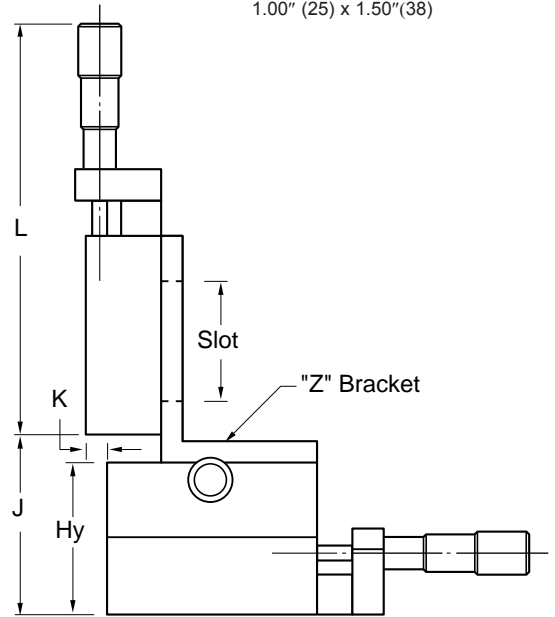
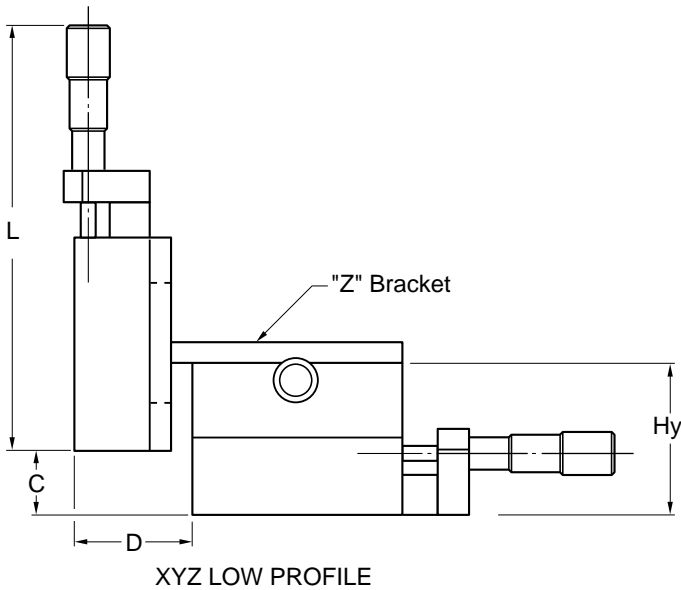

SERIES 300, 450, 750

Space saving side mount micrometer head style is available. See page 56

inch (mm)

SERIES	M	MTG. SCREW C'BORE	O	SERIES	P
300	1.187" (30.1)	#4-(M3)	.875" (22.2)	301	1.160" (29.5)
450	1.312" (33.3)	#6-(M4)	.875" (22.2)	450,453	1.770" (45.0)
750	2.00" (50.8)	#10-(M5)	1.500" (38.1)	451	2.390" (60.7)
				750,753	1.770" (45.0)
				751	2.390" (60.7)

OPTIONAL POSI-LOCK™
FOR SERIES 300, 450, 750

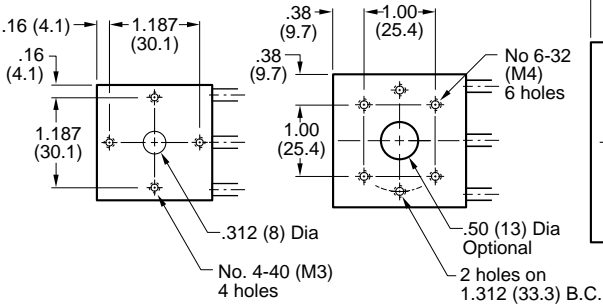
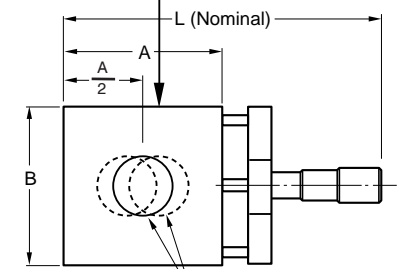
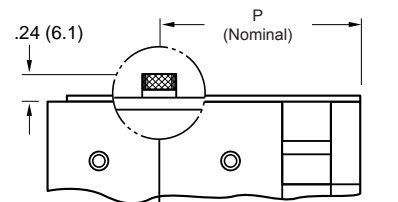

SERIES 300

SERIES 450

SERIES 750

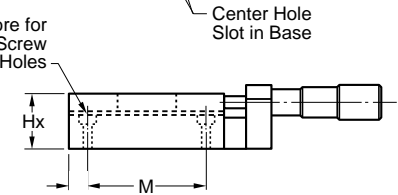
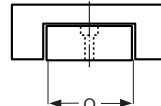

SERIES 300, 450, 750

inch (mm)

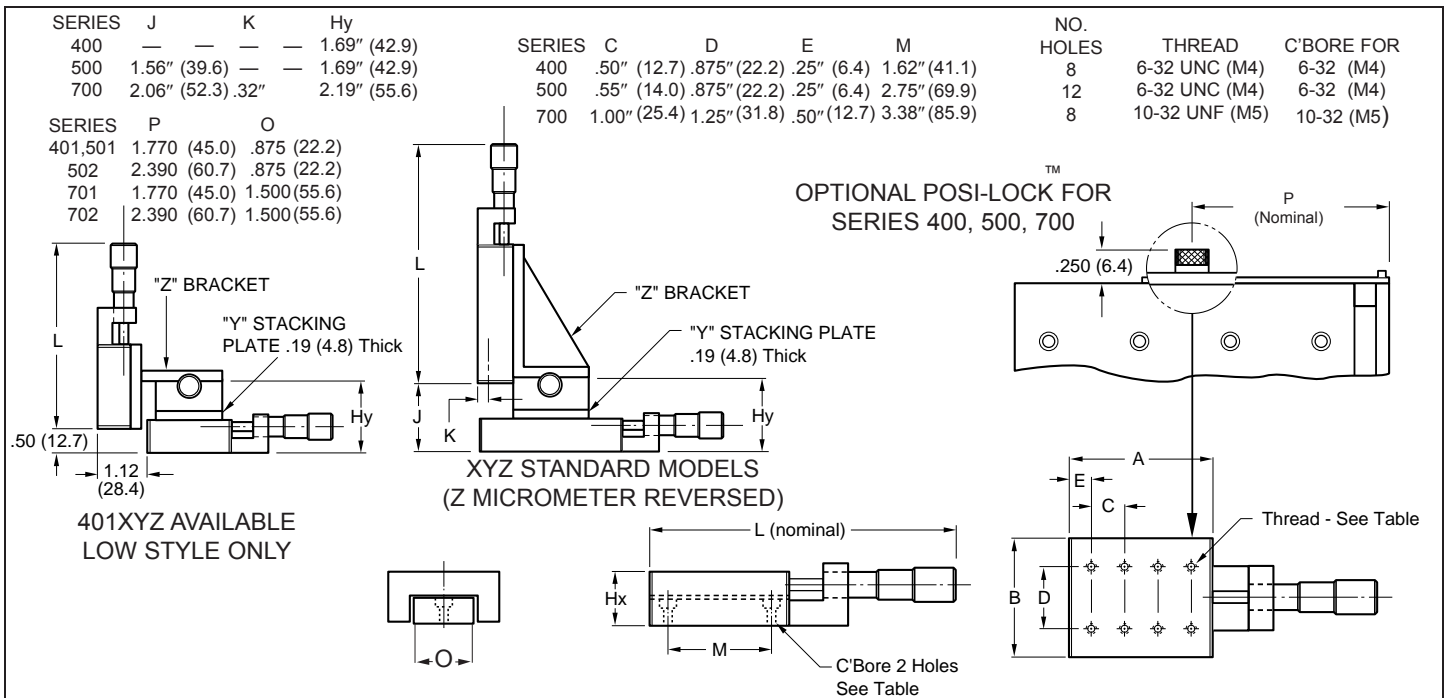

SERIES 400, 500, 700

Space saving side mount micrometer head style is available. See page 56

inch (mm)

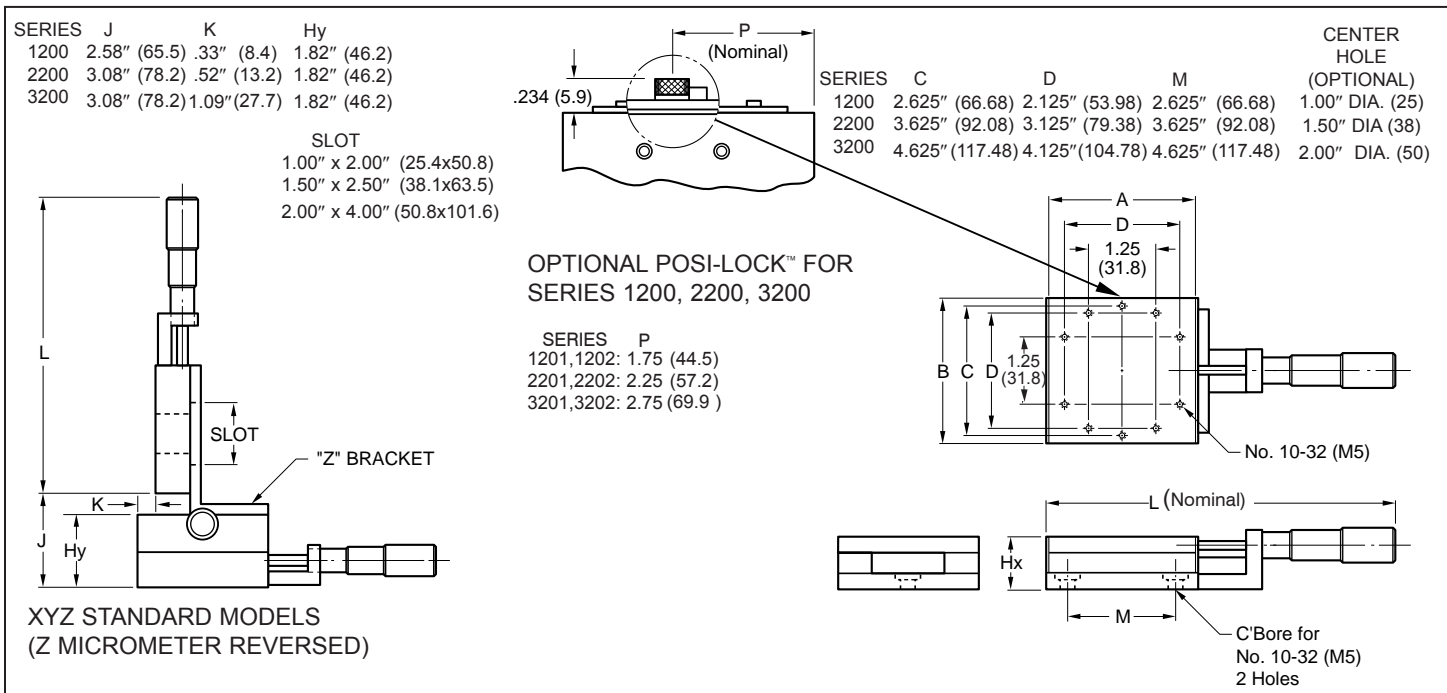

SERIES 1200, 2200, 3200

Crossed Roller Positioning Stages (Micrometer Driven)

6 Reasons to choose Del-Tron® Crossed Roller Positioning Stages

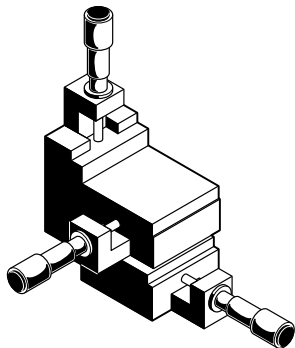

1. **High Capacity-** Greater load bearing capacity than ball types. Better for impacts and overhanging loads.
2. **Straight Line Accuracy-** Runout of 0.0001 inch per inch of travel.
3. **Wide Range-** Carriages up to 5.125" square with four inches of travel.
4. **Smooth Accurate Movement-** Spring forces hold carriage against micrometer head. Factory adjusted preload offers friction free running.
5. **Subminiature Sizes-** R99 among the smallest commercially available roller stages 3/4 inch square.
6. **Positive Locking- Posi- Lock™** feature guards against movement caused by vibration or impact.

Del-Tron® Crossed Roller Positioning Stages

Del-Tron offers over 60 models of positioning slides.

Used for gauging and positioning light and medium loads, applications include measuring instruments and optical assemblies. Del-Tron® positioners, built with the same rigorous manufacturing demands as our crossed roller slide assemblies, offer the benefits of quality construction.

Spring loaded micrometer drives allow precise repeatable adjustments with low friction and zero backlash. (Micrometers available in inch or metric units.) Slides provide accuracy to .0001"/inch of travel and repeatability of .0001". Over 60 models, support load capacities to 160 lb. Our full line includes the subminiature series with the smallest commercially available positioner, the standard series, ideal for most gauging and positioning applications, and our heavy duty series providing high load capacities with the same high accuracy and repeatability.

Positioning slides can be stacked for multi-axis applications. Standard stacked units are available in XY and XYZ configurations. Preloaded positioning slides, fully assembled, arrive ready for your use.

Positioners are available in black anodized finish or other finishes on request.

Nomenclature

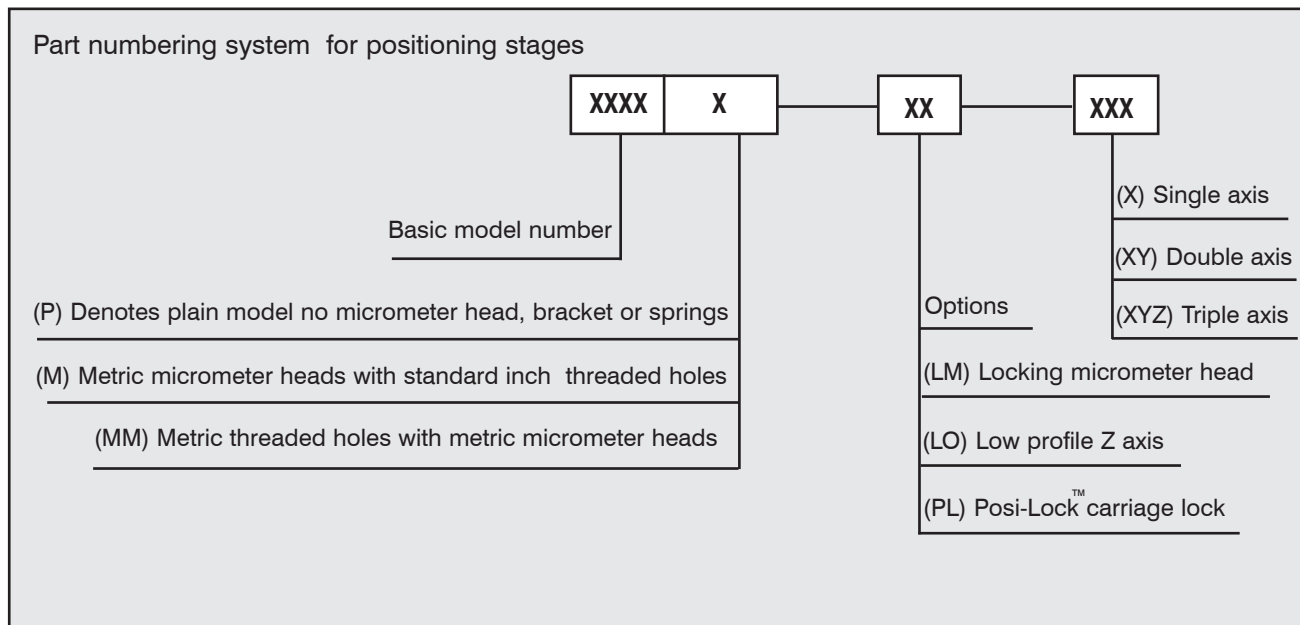

- Posi-Lock™ feature consists of a steel shim and extended micrometer bracket secured by a screw mounted to the side of the stage carriage. This allows the user to positively lock the position of the carriage during use. Posi-Lock is standard on the model R99 and optional on all others
- Locking micrometer heads are available to positively lock the micrometer setting. Not available for models R99, R101, R201, R301 and 2" (50mm) travel micrometers.
- Space saving side mount micrometer head style available. See page 53.
- Loads in Z axis will extend springs if too heavy. Series R400, R500, R700, R1200, R2200 and R3200 have micrometer bracket reversed to prevent this and increase Z axis capacity.
- Custom designs quoted on request.
- Metric threaded mounting holes optional at no additional cost.
- Metric Micrometer Heads available at no additional cost.
- (P) Plain style are free floating slides without micrometer head, brackets or springs.
- (P-PL) Plain with Posi-Lock™ available. Only on R1200, R2200, & R3200 series.

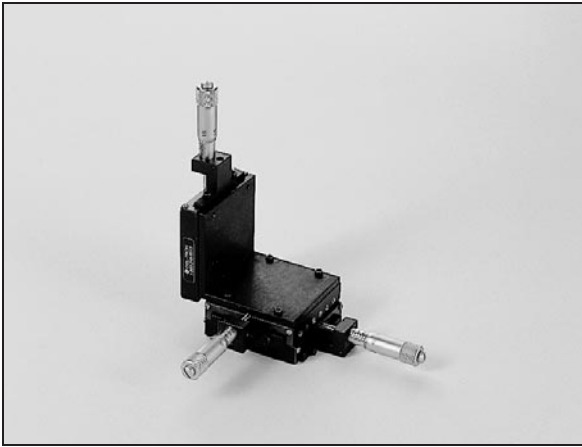

Crossed Roller Positioning Stages

Specifications:

Straight Line Accuracy	.0001"/inch of travel
Repeatability	.0001"
Coefficient of Friction	0.003 typical
Drive	Micrometer, .001" graduations standard, .01 mm graduations optional
Construction	Aluminum carriage and base, hardened steel shafts and balls, mild steel endcaps
Finish	Black anodize standard; other finishes on request

moment load ratings + load / life formulas. pg. 97

MODEL	TRAVEL*	WORK SURFACE A X B	OVERALL DIMENSIONS		LOAD CAPACITY, LB		THROUGH HOLE
			L	Hx	X, XY	Z	
R 99	.25 (6.4mm)	.75 X .75	2.28	.53	40	1.25	NO
R101	.50 (13mm)	1.25 X 1.25	3.25	.38	23	1.25	NO
R201	.50 (13mm)	1.75 X 1.75	3.75	.38	23	1.25	NO
R301	.50 (13mm)	1.50 X 1.50	3.50	.62	40	2	.312 DIA.
R450	.50 (13 mm)	1.75 X 1.75	4.38	.75	40	2	NO
R451	1.00 (25 mm)	1.75 X 1.75	5.88	.75	40	2	NO
R453	.50 (13 mm)	1.75 X 1.75	4.38	.75	40	2	.50 DIA.
R750	.50 (13 mm)	2.62 X 2.62	5.25	1.00	120	2	NO
R751	1.00 (25 mm)	2.62 X 2.62	6.75	1.00	120	2	NO
R753	.50 (13 mm)	2.62 X 2.62	5.25	1.00	120	2	1.00 DIA.
R401	.50 (13 mm)	2.00 X 1.75	4.62	.75	40	20	NO
R501	.50 (13 mm)	3.25 X 1.75	5.86	.75	80	20	NO
R502	1.00 (25 mm)	3.25 X 1.75	7.41	.75	80	20	NO
R701	.50 (13 mm)	4.00 X 2.62	6.62	1.00	160	20	NO
R702	1.00 (25 mm)	4.00 X 2.62	8.25	1.00	160	20	NO
R1201	1.00 (25 mm)	3.12 X 3.12	7.25	.91	85	30	NO
R1203	1.00 (25 mm)	3.12 X 3.12	7.25	.91	85	30	1.00 DIA.
R2201	1.00 (25 mm)	4.12 X 4.12	8.25	.91	85	30	NO
R2202	2.00(50mm)	4.12 X 4.12	10.25	.91	85	30	NO
R2203	1.00 (25 mm)	4.12 X 4.12	8.25	.91	85	30	1.50 DIA.
R2204	2.00(50mm)	4.12 X 4.12	10.25	.91	85	30	1.50 DIA.
R3201	1.00 (25 mm)	5.12 X 5.12	9.25	.91	85	30	NO
R3202	2.00(50mm)	5.12 X 5.12	11.25	.91	85	30	NO
R3203	1.00 (25 mm)	5.12 X 5.12	9.25	.91	85	30	2.00 DIA.
R3204	2.00(50mm)	5.12 X 5.12	11.25	.91	85	30	2.00 DIA.
PLAIN MODELS (WITHOUT MICROMETER, BRACKETS OR SPRINGS), X AND XY CONFIGURATIONS ONLY.							
R101P	.50 (13mm)	1.25 X 1.25	—	.38	23	—	NO
R201P	.50 (13mm)	1.75 X 1.75	—	.38	23	—	NO
R301P	.50 (13mm)	1.50 X 1.50	—	.62	40	—	.312 DIA.
R451P	1.00 (25mm)	1.75 X 1.75	—	.75	40	—	NO
R452P	1.00 (25mm)	1.75 X 1.75	—	.75	40	—	.50 DIA.
R751P	1.00 (25mm)	2.62 X 2.62	—	1.00	120	—	NO
R752P	1.00 (25mm)	2.62 X 2.62	—	1.00	120	—	1.00 DIA.
R1202P	2.00 (50mm)	3.12 X 3.12	—	.91	85	—	NO
R1204P	2.00 (50mm)	3.12 X 3.12	—	.91	85	—	1.00 DIA.
R2205P	3.00 (75mm)	4.12 X 4.12	—	.91	85	—	NO
R2206P	3.00 (75mm)	4.12 X 4.12	—	.91	85	—	1.50 DIA.
R3205P	4.00 (100mm)	5.12 X 5.12	—	.91	85	—	NO
R3206P	4.00 (100mm)	5.12 X 5.12	—	.91	85	—	2.00

inch (mm)

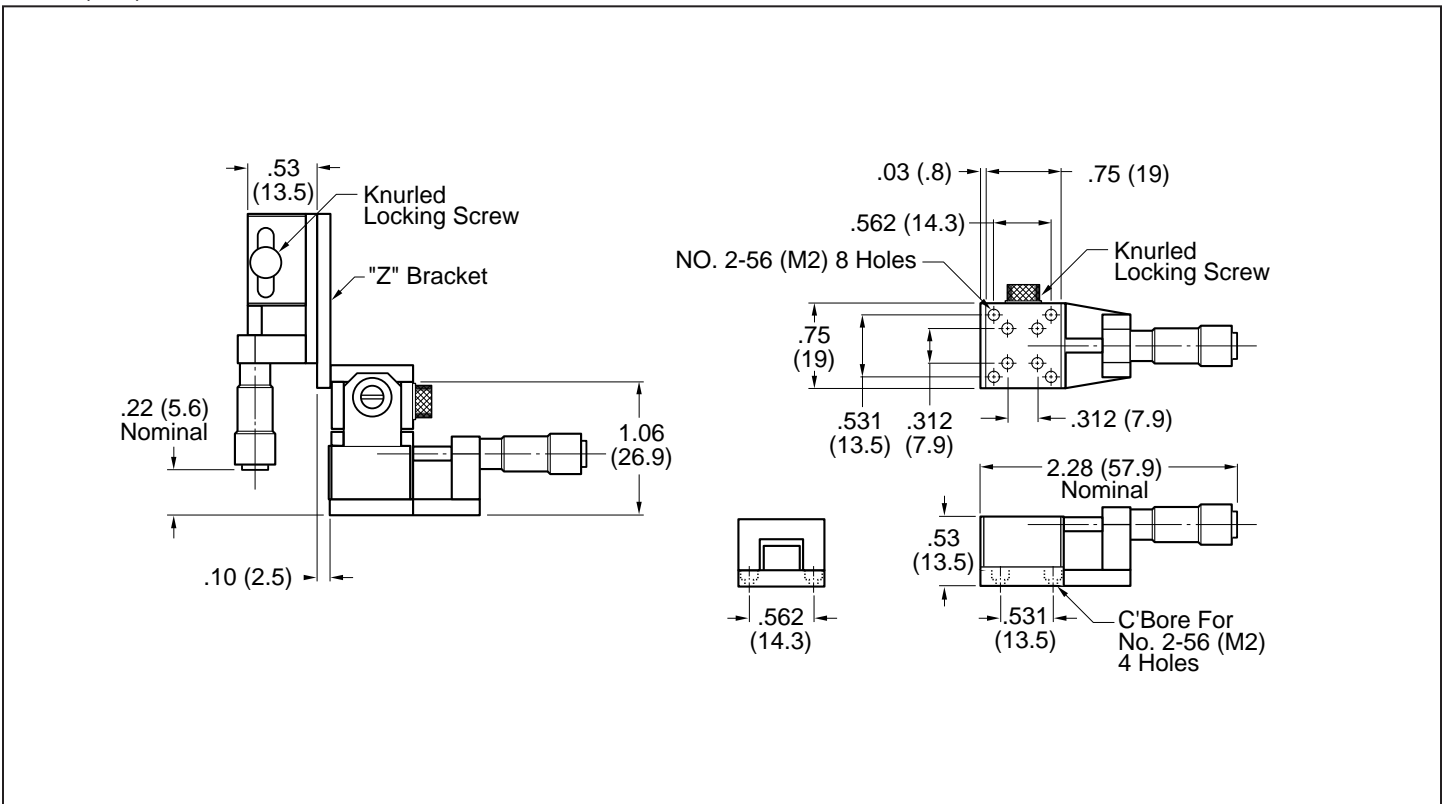

SERIES R99

Space saving side mount micrometer head style is available. See page 56

inch (mm)

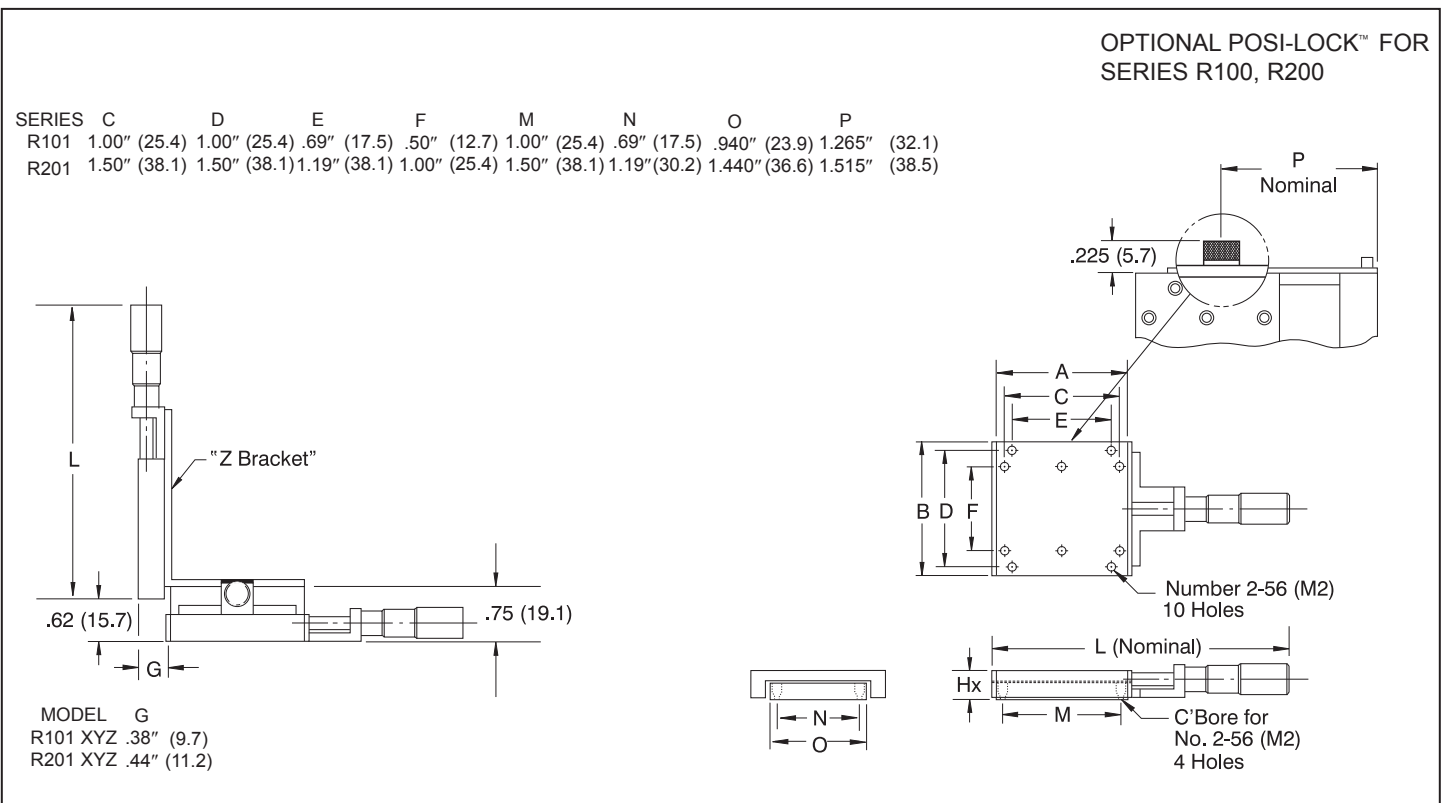

SERIES R100, R200

inch (mm)

SERIES	C	D	J	K	Hy
R 300	.44" (11.2)	1.00" (25.4)	1.62" (41.1)	.32" (8.1)	1.25" (31.8)
R 450	.69" (17.5)	1.12" (28.4)	2.00" (50.8)	—	1.50" (38.1)
R 750	.69" (17.5)	1.50" (38.1)	2.62" (66.5)	.06" (1.5)	2.00" (50.8)

SLOT
.38" (8) x .88" (22)
.50" (3) x 1.00" (25)
1.00" (25) x 1.50" (38)

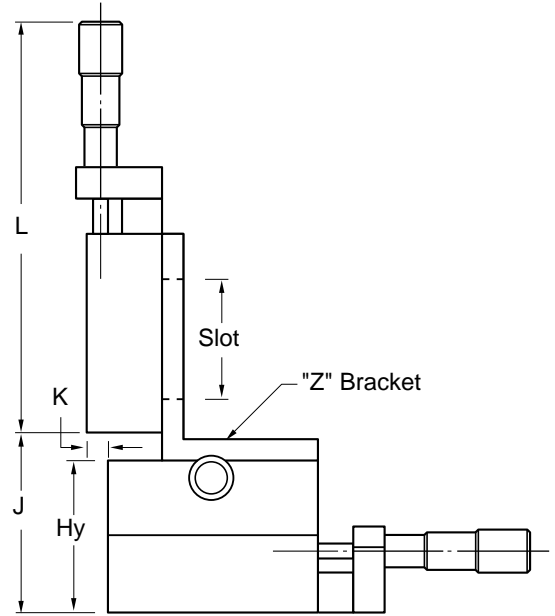
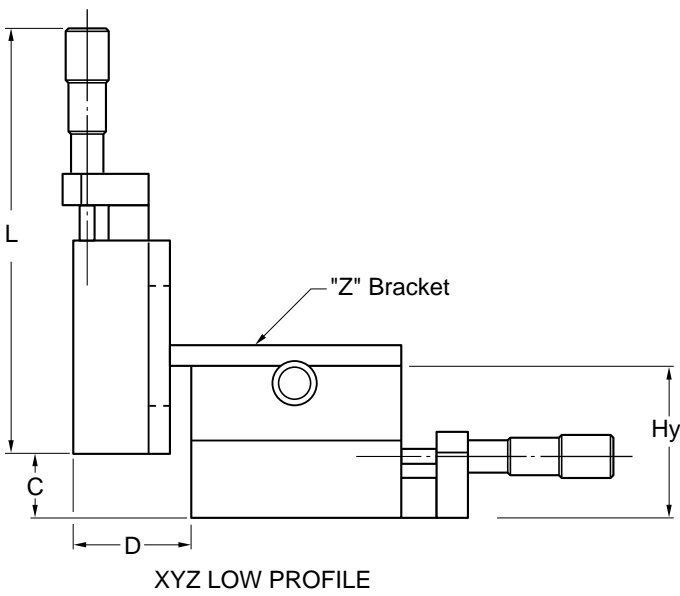

SERIES R300, R450, R750

Space saving side mount micrometer head style is available. See page 56

inch (mm)

SERIES	M	MTG. SCREW C'BORE	O	SERIES	P
R300	1.187"	#4-M3	.875 (22.2)	R301	1.160" (29.5)
R450	1.312"	#6-M4	.875 (22.2)	R450,R453	1.770" (45.0)
R750	2.00"	#10-M5	1.500 (38.1)	R451	2.390" (60.7)
				R750,R753	1.770" (45.0)
				R751	2.390" (60.7)

OPTIONAL POSI-LOCK™ FOR SERIES R300, R450, R750

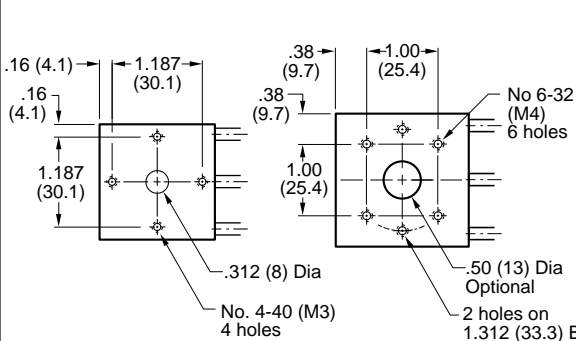

SERIES R300

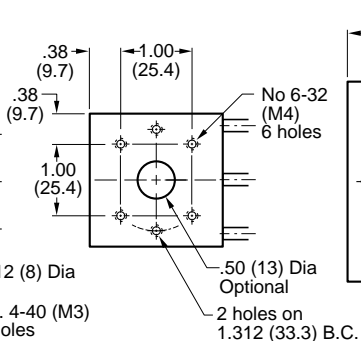

SERIES R450

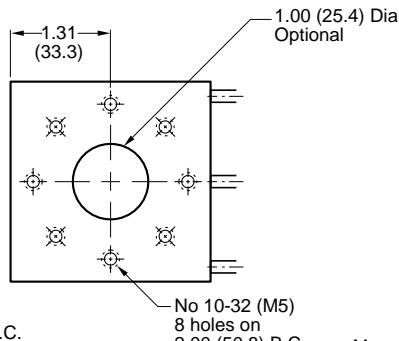

SERIES R750

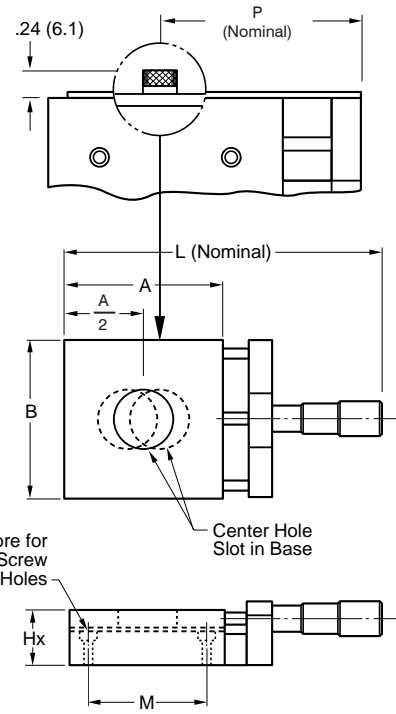
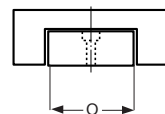

SERIES R300, R450, R750

inch (mm)

OPTIONAL POSI-LOCK™ FOR SERIES R400, R500, R700

MODEL R401-XYZ AVAILABLE LOW STYLE ONLY

MODEL R500 & R700 XYZ

XYZ STANDARD MODELS (Z MICROMETER REVERSED)

SERIES	C	D	E	M	NO. HOLES	THREAD	C'BORE FOR
R400	.50" (12.7)	.875" (22.2)	.25" (6.4)	1.62" (41.1)	8	6-32 UNC (M4)	6-32 (M4)
R500	.55" (14.0)	.875" (22.2)	.25" (6.4)	2.75" (69.9)	12	6-32 UNC (M4)	6-32 (M4)
R700	1.00" (25.4)	1.25" (31.8)	.50" (12.7)	3.38" (85.9)	8	10-32 UNF (M5)	10-32 (M5)

SERIES	J	K	Hy	SERIES	P	O
R400	—	—	1.69" (42.9)	R401,R501	1.770 (45.0)	.875 (22.2)
R500	1.56" (39.6)	—	1.69" (42.9)	R502	2.390 (60.7)	.875 (22.2)
R700	2.06" (52.3)	.32"	2.19" (55.6)	R701	1.770 (45.0)	1.500 (55.6)
				R702	2.390 (60.7)	1.500 (55.6)

SERIES R400, R500, R700

inch (mm)

Space saving side mount micrometer head style is available. See page 56

SERIES	J	K	Hy
R1200	2.58" (65.5)	.33" (8.38)	1.82" (46.2)
R2200	3.08" (78.2)	.52" (13.21)	1.82" (46.2)
R3200	3.08" (78.2)	1.09" (27.69)	1.82" (46.2)

SLOT
 1.00" x 2.00" (25.4x50.8)
 1.50" x 2.50" (38.1x63.5)
 2.00" x 4.00" (50.8x101.6)

OPTIONAL POSI-LOCK™ FOR SERIES R1200, R2200, R3200

XYZ STANDARD MODELS (Z MICROMETER REVERSED)

SERIES P
 R1201,R1202: 1.75
 R2201,R2202: 2.25
 R3201,R3202: 2.75

SERIES	C	D	M	CENTER HOLE (OPTIONAL)
R1200	2.625" (66.68)	2.125" (53.98)	2.625" (66.68)	1.00" DIA. (25)
R2200	3.625" (92.08)	3.125" (79.38)	3.625" (92.08)	1.50" DIA (38)
R3200	4.625" (117.48)	4.125" (104.78)	4.625" (117.48)	2.00" DIA. (50)

No. 10-32 (M5)

C'Bore for No. 10-32 (M5) 2 Holes

SERIES R1200, R2200, R3200

Compact Side Drive Positioners

6 Reasons to choose Del-Tron® Side Drive Positioning Stages

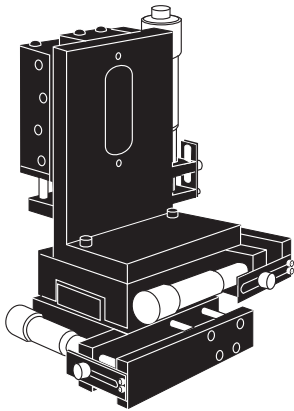

- 1. Versatile-** Reduced overall length makes Del-Tron® Side Drive stages ideal for restricted space applications.
- 2. Posi- Lock™** - Optional positive locking feature prevents movement of carriage.
- 3. Accurate Measurements:** Carriages are spring loaded against micrometer heads with 0.001" (0.01mm) graduations.
- 4. Adaptable-** One, two or three axis models can be used in any orientation.
- 5. Easy To Use-** Standard counterbored holes in base and threaded holes in carriage.
- 6. Wide Selection-** Subminiature and low profile models.

Del-Tron® Side Drive Positioning Stages

Del-Tron offers over 50 models of positioning slides. (Available in either ball bearing or crossed roller type.)

Used for gauging and positioning light and medium loads, applications include measuring instruments and optical assemblies. Del-Tron® positioners, built with the same rigorous manufacturing demands as our ball slide assemblies, offer the benefits of quality construction.

Spring loaded micrometer drives allow precise repeatable adjustments with low friction and zero backlash. (Micrometers available in inch or metric units.) Slides provide accuracy to .0001"/inch of travel and repeatability of .0001". Models can support load capacities to 160 lb. Our full line includes the subminiature series with the smallest commercially available positioner, the standard series, ideal for most gauging and positioning applications, and our heavy duty series providing high load capacities with the same high accuracy and repeatability.

Positioning slides can be stacked for multi-axis applications. Standard stacked units are available in XY and XYZ configurations. Preloaded positioning slides, fully assembled, arrive ready for your use.

Positioners are available in black anodized finish or other finishes on request.

Nonmenclature

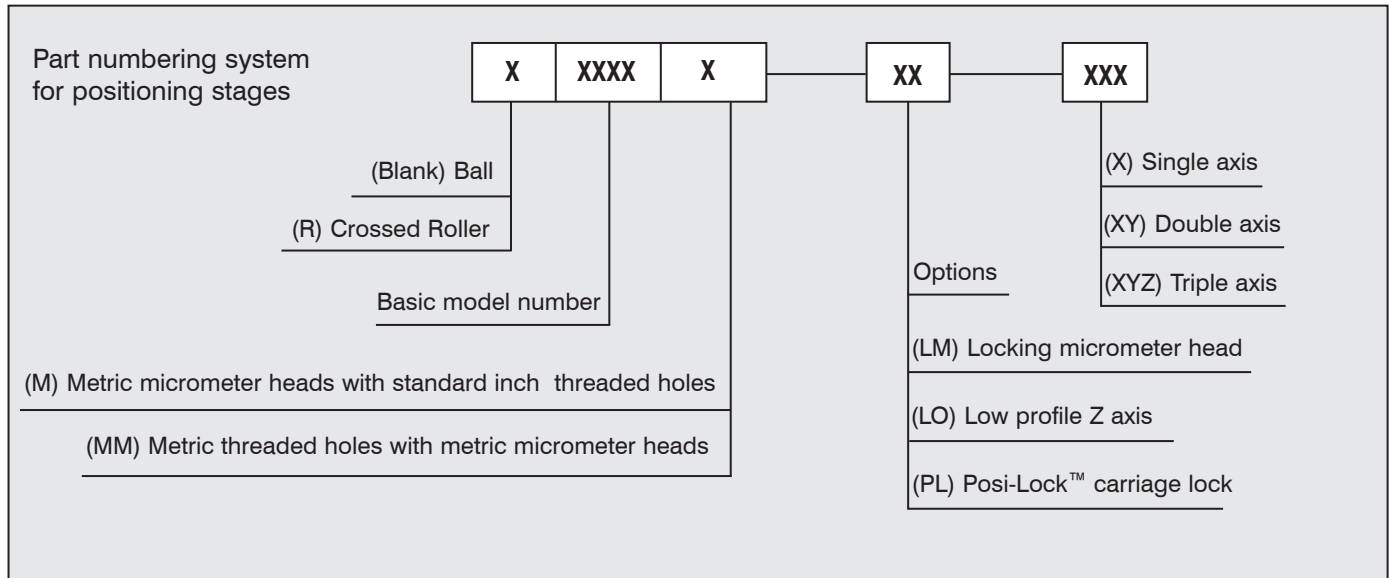

- Posi-Lock™ feature consists of steel shim and extended micrometer bracket secured by a screw mounted to the side of the micrometer bracket. This allows the user to positively lock the position of the carriage during use. Posi-Lock™ is standard on the model 99SD, R99SD and optional on all others.
- Locking micrometer heads are available to positively lock the micrometer setting. Not available for models 99SD, 101SD, 201SD, 301SD, R99SD, R101SD, R201SD, R301SD and 2" (50mm) travel micrometers.
- Custom designs quoted on request.
- Metric threaded mounting holes optional at no additional cost.
- Metric micrometers available at no additional cost.

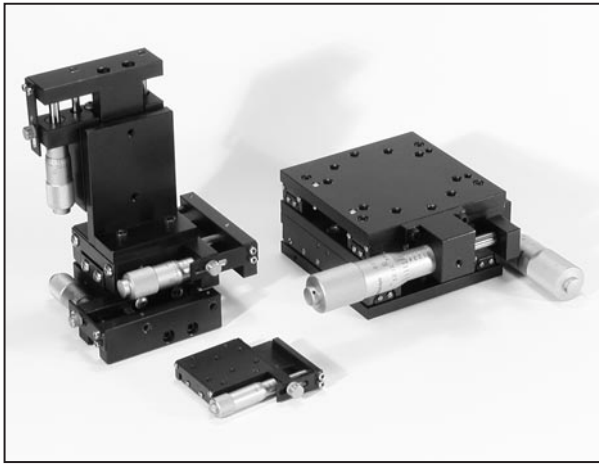

Side Drive Positioning Stages

Specifications:

Straight Line Accuracy	Ball: .0005"/inch of travel Roller: .0001"/inch of travel
Repeatability	Ball: .0002"/inch of travel Roller: .0001"/inch of travel
Coefficient of Friction	0.003 typical
Drive	Micrometer, .001" graduations standard, .01 mm graduations optional
Construction	Aluminum carriage and base, hardened steel shafts and balls or rollers, mild steel endcaps
Finish	Black anodize standard; other finishes on request

moment load ratings + load / life formulas. pg. 97

*Travel is 1/2 distance from center in either direction.											
MODEL		TRAVEL *	WORK SURFACE	OVERALL DIMENSIONS			LOAD CAPACITY, LB				THROUGH HOLE
Ball Slide	Crossed Roller Slide			A X B	L	Hx	W	Ball Slide		Crossed Roller Slide	
		X, XY	Z					X, XY	Z		
99SD	R99SD	.25 (6.4 mm)	.75 X .75	1.48	.53	1.29	5	2.5	40	20	NO
101SD	R101SD	.50 (13 mm)	1.25 X 1.25	2.16	.38	1.75	4	2	23	18	NO
201SD	R201SD	.50 (13 mm)	1.75 X 1.75	2.42	.38	2.26	4	2	23	13	NO
301SD	R301SD	.50 (13 mm)	1.50 X 1.50	2.18	.62	2.01	12	6	40	20	.312 DIA.
450SD	R450SD	.50 (13 mm)	1.75 X 1.75	2.95	.75	2.40	20	10	40	20	NO
451SD	R451SD	1.00 (25 mm)	1.75 X 1.75	4.51	.75	2.55	20	10	40	20	NO
453SD	R453SD	.50 (13 mm)	1.75 X 1.75	2.95	.75	2.40	20	10	40	20	.50 DIA.
750SD	R750SD	.50 (13 mm)	2.62 X 2.62	3.52	1.00	3.27	60	30	120	60	NO
751SD	R751SD	1.00 (25 mm)	2.62 X 2.62	4.48	1.00	3.43	60	30	120	60	NO
753SD	R753SD	.50 (13 mm)	2.62 X 2.62	3.52	1.00	3.27	60	30	120	60	1.00 DIA.
401SD	R401SD	.50 (13 mm)	2.00 X 1.75	2.95	.75	2.40	20	20	40	20	NO
501SD	R501SD	.50 (13 mm)	3.25 X 1.75	4.15	.75	2.40	42	20	80	40	NO
502SD	R502SD	1.00 (25 mm)	3.25 X 1.75	4.51	.75	2.55	42	20	80	40	NO
701SD	R701SD	.50 (13 mm)	4.00 X 2.62	4.90	1.00	3.31	60	30	160	80	NO
702SD	R702SD	1.00 (25 mm)	4.00 X 2.62	5.18	1.00	3.43	60	30	160	80	NO
1201SD	R1201SD	1.00 (25 mm)	3.12 X 3.12	4.75	.91	4.04	30	30	85	43	NO
1203SD	R1203SD	1.00 (25 mm)	3.12 X 3.12	4.75	.91	4.04	30	30	85	43	1.00 DIA.
2201SD	R2201SD	1.00 (25 mm)	4.12 X 4.12	4.75	.91	5.04	30	30	85	43	NO
2202SD	R2202SD	2.00 (50 mm)	4.12 X 4.12	6.76	.91	5.04	30	30	85	43	NO
2203SD	R2203SD	1.00 (25 mm)	4.12 X 4.12	4.75	.91	5.04	30	30	85	43	1.50 DIA.
2204SD	R2204SD	2.00 (50 mm)	4.12 X 4.12	6.76	.91	5.04	30	30	85	43	1.50 DIA.
3201SD	R3201SD	1.00 (25 mm)	5.12 X 5.12	5.12	.91	6.04	30	30	85	43	NO
3202SD	R3202SD	2.00 (50 mm)	5.12 X 5.12	6.76	.91	6.04	30	30	85	43	NO
3203SD	R3203SD	1.00 (25 mm)	5.12 X 5.12	5.12	.91	6.04	30	30	85	43	2.00 DIA.
3204SD	R3204SD	2.00 (50 mm)	5.12 X 5.12	6.76	.91	6.04	30	30	85	43	2.00 DIA.

inch (mm)

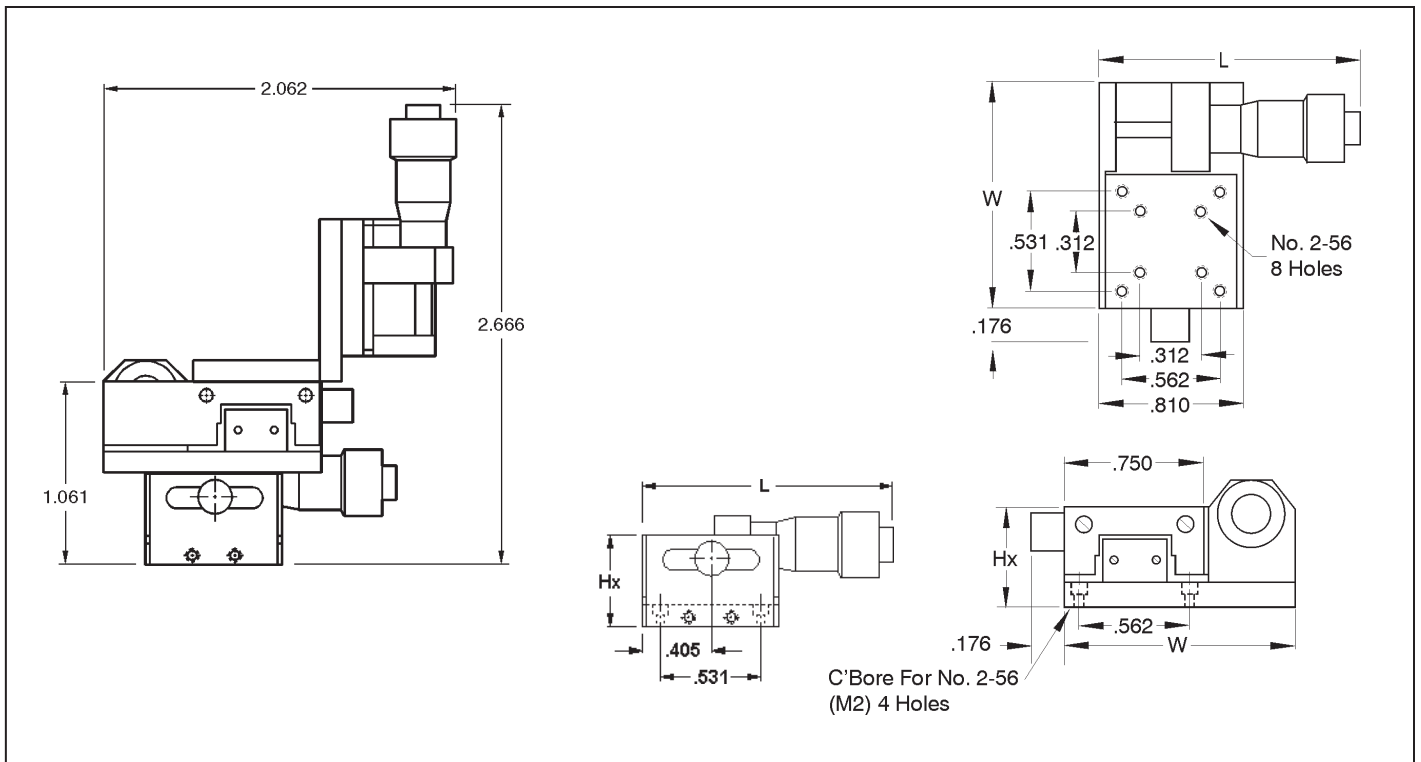

SERIES 99SD, R99SD

inch (mm)

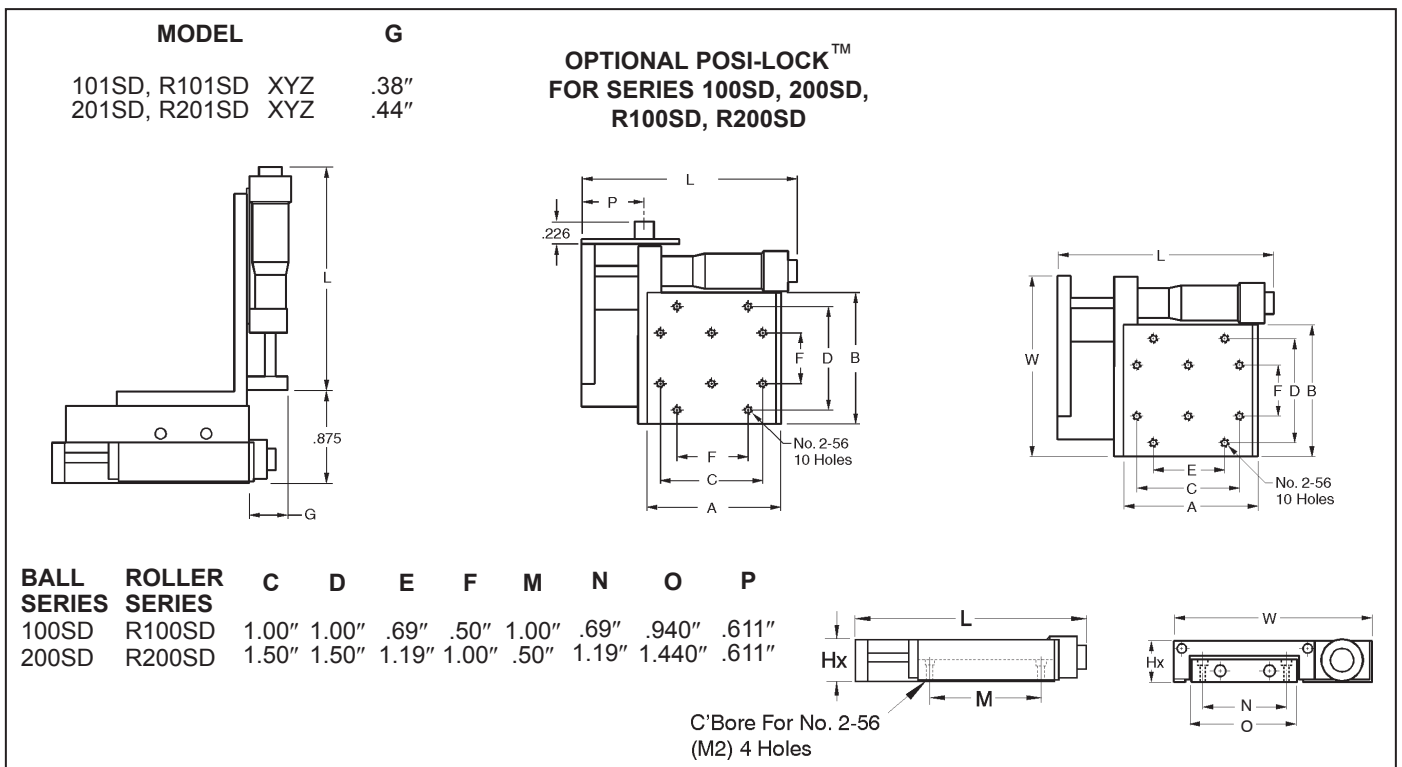

SERIES 100SD, 200SD, R100SD, R200SD

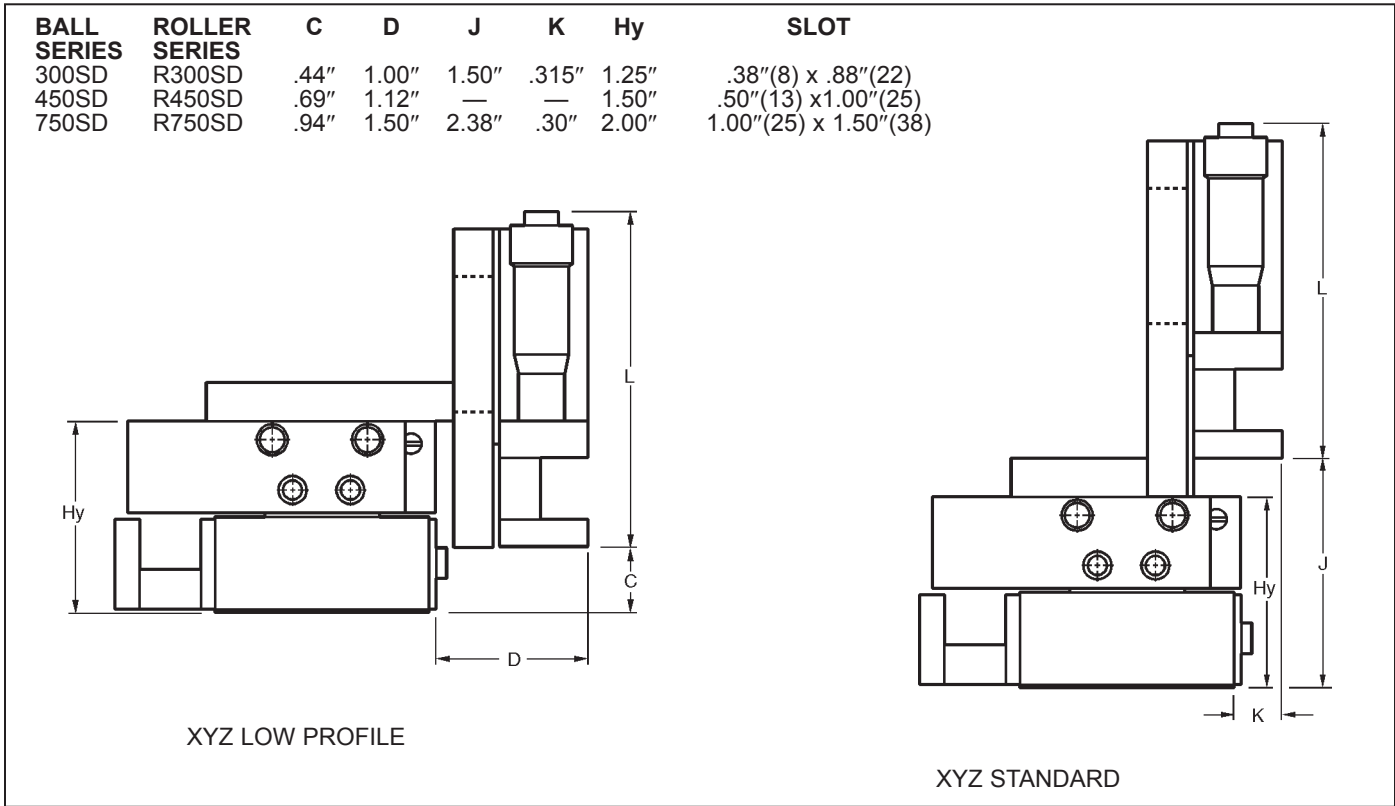

SERIES 300SD, 450SD, 750SD, R300SD, R450SD, R750SD

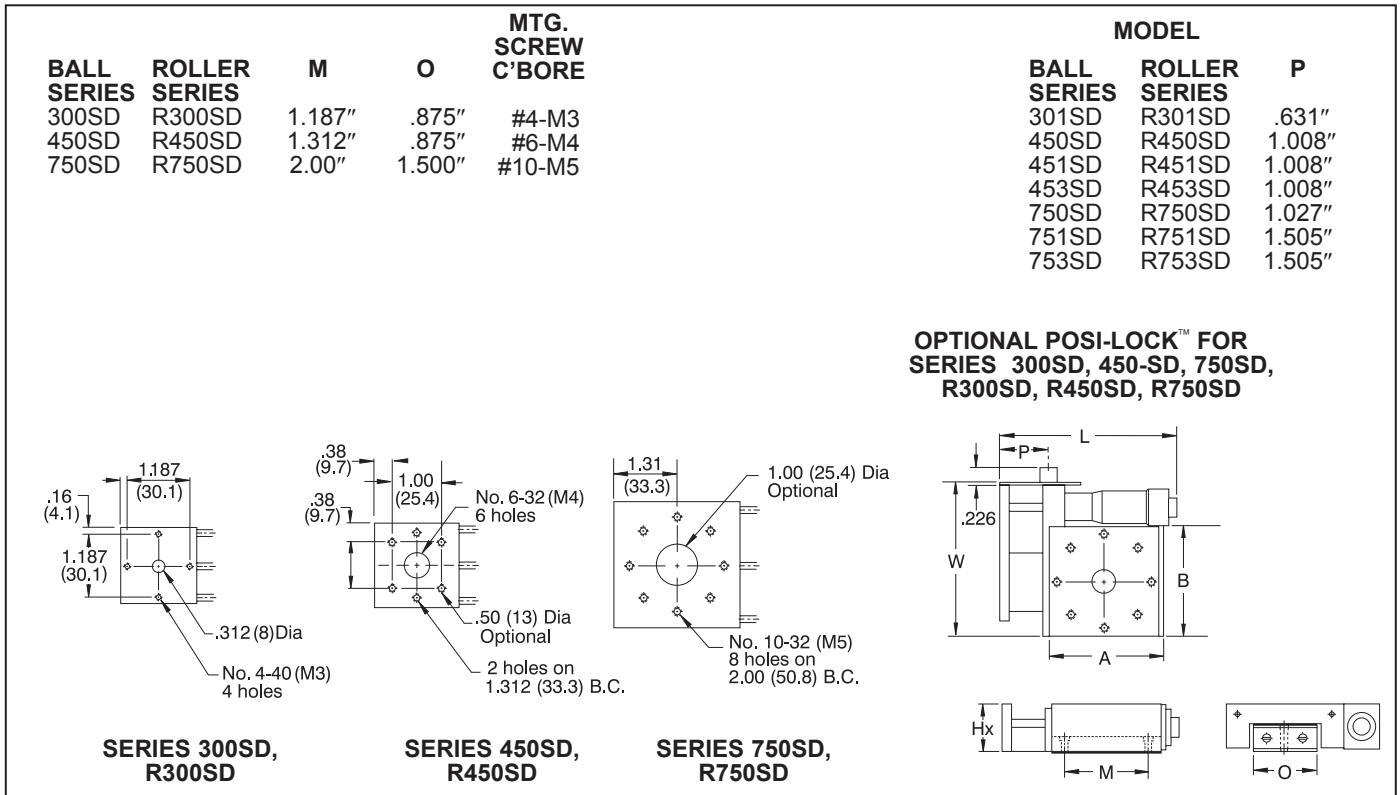

SERIES 300SD, 450SD, 750SD, R300SD, R450SD, R750SD

inch (mm)

ROLLER SERIES	ROLLER SERIES	J	K	Hy	C	D	E	NO. HOLES	THREAD	C'BORE FOR	M	O	MODEL	P
400SD	R400SD	1.94"	.573"	1.69"	.50"	.875"	.25"	8	6-32 UNC (M4)	6-32 (M4)	1.62"	.875"	401	1.008"
500SD	R500SD	1.94"	—	1.69"	.55"	.875"	.25"	12	6-32 UNC (M4)	6-32 (M4)	2.75"	.875"	501	1.008"
700SD	R700SD	2.56"	.366"	2.19"	1.00"	1.25"	.50"	8	10-32 UNF (M5)	10-32 (M5)	3.38"	1.500"	502	1.505"
													701	1.029"
													702	1.505"

OPTIONAL POSI-LOCK™ FOR SERIES 400SD, 500SD, 700SD, R400SD, R500SD, R700SD

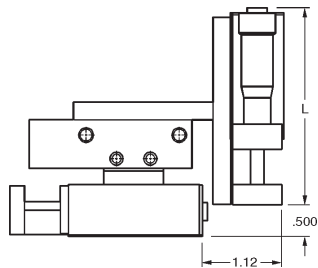

401SD-XYZ, R401SD-XYZ
AVAILABLE
LOW STYLE ONLY

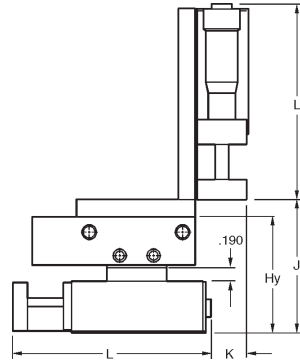

XYZ STANDARD MODELS

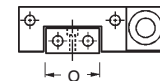
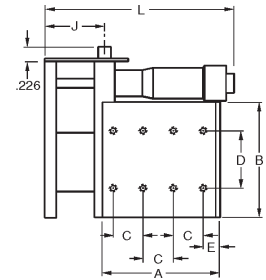
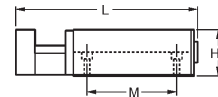
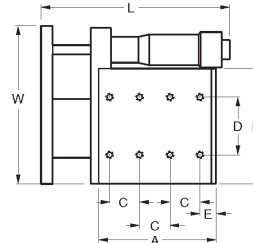

SERIES 400SD, 500SD, 700SD, R400SD, R500SD, R700SD

inch (mm)

BALL SERIES	ROLLER SERIES	J	K	SLOT	Hy	C	D	M	P	CENTER HOLE (OPTIONAL)
1200SD	R1200SD	2.58"	.33"	1.00" x 2.00"	1.82"	2.625"	2.125"	2.625"	1.75"	1.00" DIA. (25MM)
2200SD	R2200SD	3.08"	.52"	1.50" x 2.50"	1.82"	3.625"	3.125"	3.625"	2.19"	1.50" DIA. (38MM)
3200SD	R3200SD	3.08"	1.09"	2.00" x 4.00"	1.82"	4.625"	4.125"	4.625"	2.75"	2.00" DIA. (50MM)

OPTIONAL POSI-LOCK™ FOR SERIES 1200SD, 2200SD, 3200SD, R1200SD, R2200SD, R3200SD

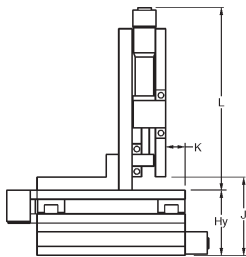

XYZ STANDARD MODELS

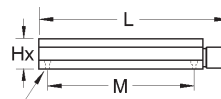
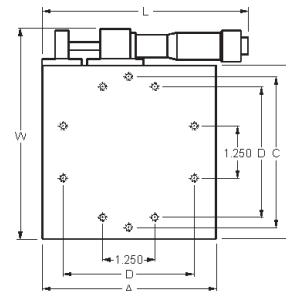
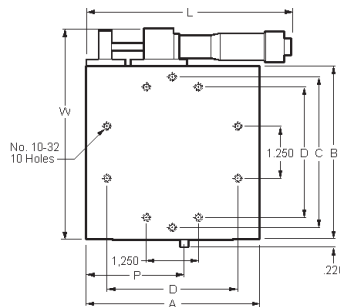

C'Bore For No. 10-32 (M5)
2 Holes

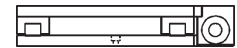

SERIES 1200SD, 2200SD, 3200SD, R1200SD, R2200SD, R3200SD

Low Profile Crossed Roller Slide Tables

6 Reasons to choose Del-Tron® Low Profile Crossed Roller Slide Tables

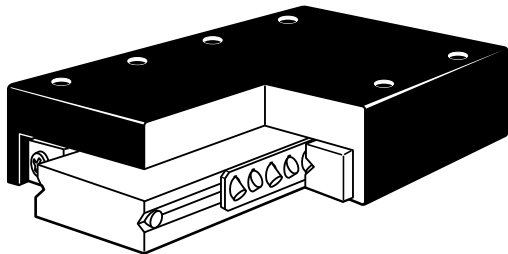

1. Compact & Low Profile.
2. High Accuracy (0.0001"/1") Travel.
3. Inch Type Mounting Holes.
4. Light Weight Aluminum Carriage.
5. 400 Series Stainless Steel Models Available
6. 21 Size & Travel Combinations.

Low Profile Slide Tables

Del-Tron® LPT slides are low profile, high accuracy slide tables featuring easily adjustable preload and light weight aluminum carriage. Standard inch type threaded and counterbored holes allow easy mounting and installation. The bearing base consists of a two sided single inner rail flanked by two precision V grooved outer rails. High precision rollers captive in a stainless steel cage and positive internal travel stops assure smooth accurate reciprocating motion.

400 series Stainless steel models (ss) offer aluminum carriage with stainless steel rails, rollers, cages and fasteners.

LPT slides are ideal anywhere low friction reciprocating mechanisms are used in automated equipment.

Low Profile Crossed Roller Tables

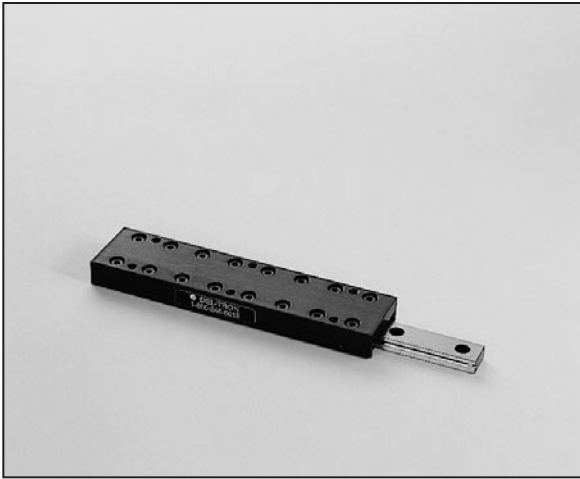

Specifications:

Straight Line Accuracy
0.0001" per inch of travel.

Positional Repeatability
0.0001"

Coefficient of Friction
0.003 typical

Construction

Aluminum carriage, hardened steel crossed roller rail set with double v-grooved inner rail.

Finish

Black anodized carriage, hardened steel base.

BASE MOUNTING DIMENSIONS

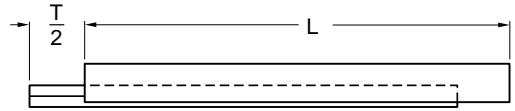
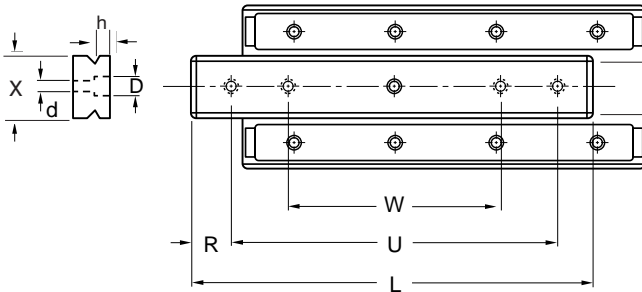

moment load ratings + load / life formulas. pg. 98

*Travel is 1/2 distance from center in either direction.

MODEL	400 SERIES STAINLESS STEEL	TRAVEL* T	LENGTH L	LOAD CAPACITY LBF (kgf)	BASE MOUNTING HOLES (COUNTERBORED)			CARRIAGE MOUNTING HOLES (THREADED)	
					NO. HOLES	SPACING U	W	NO. HOLES	SPACING M
LPT-1025	SS	0.473 (12)	0.984 (25)	50 (23)	2	0.709 (18)	—	4	0.709 (18)
LPT-1035	SS	0.709 (18)	1.378 (35)	70 (32)	2	0.984 (25)	—	4	1 × 1.102 (28)
LPT-1045	SS	0.984 (25)	1.772 (45)	103 (47)	4	1.496 (38)	0.984 (25)	4	1 × 0.788 (20)
LPT-1055	SS	1.260 (32)	2.165 (55)	118 (54)	4	1.890 (48)	1.142 (29)	4	1 × 1.181 (30)
LPT-1065	SS	1.575 (40)	2.559 (65)	132 (60)	4	2.165 (55)	1.220 (31)	6	2 × 0.788 (20)
LPT-1075	SS	1.772 (45)	2.953 (75)	160 (73)	4	2.559 (65)	1.378 (35)	4	1 × 1.181 (30)
LPT-1085	SS	1.969 (50)	3.347 (85)	173 (79)	4	2.953 (75)	1.575 (40)	6	2 × 1.181 (30)
LPT-2035	SS	0.709 (18)	1.378 (35)	88 (40)	2	0.984 (25)	—	4	1 × 1.102 (28)
LPT-2050	SS	1.181 (30)	1.969 (50)	138 (63)	2	1.378 (35)	—	4	1 × 1.693 (43)
LPT-2065	SS	1.575 (40)	2.559 (65)	165 (75)	4	2.165 (55)	1.299 (33)	4	1 × 1.181 (30)
LPT-2080	SS	1.969 (50)	3.150 (80)	209 (95)	4	2.756 (70)	1.575 (40)	4	1 × 1.772 (45)
LPT-2095	SS	2.363 (60)	3.740 (95)	231 (105)	4	3.347 (85)	1.772 (45)	6	2 × 1.181 (30)
LPT-2110	SS	2.756 (70)	4.330 (110)	264 (120)	4	3.740 (95)	1.969 (50)	4	1 × 1.772 (45)
LPT-2125	SS	3.150 (80)	4.921 (125)	286 (130)	4	4.330 (110)	2.165 (55)	6	2 × 1.772 (45)
LPT-3055	SS	1.181 (30)	2.165 (55)	277 (126)	2	1.575 (40)	—	4	1 × 1.575 (40)
LPT-3080	SS	1.772 (45)	3.150 (80)	404 (184)	4	2.677 (68)	1.693 (43)	4	1 × 2.560 (65)
LPT-3105	SS	2.362 (60)	4.134 (105)	484 (220)	4	3.543 (90)	2.165 (55)	4	1 × 1.969 (50)
LPT-3130	SS	2.953 (75)	5.118 (130)	605 (275)	4	4.528 (115)	2.559 (65)	4	1 × 2.953 (75)
LPT-3155	SS	3.543 (90)	6.102 (155)	682 (310)	4	5.512 (140)	3.740 (95)	6	2 × 1.969 (50)
LPT-3180	SS	4.134 (105)	7.087 (180)	781 (355)	4	6.496 (165)	3.346 (85)	4	1 × 2.953 (75)
LPT-3205	SS	5.118 (130)	8.070 (205)	825 (375)	4	7.480 (190)	3.543 (90)	6	2 × 2.953 (75)

Please specify (SS) for Stainless Steel

Mounting Dimensions								
SERIES	CARRIAGE		BASE					
	SPACING N	P	THREAD J	DEPTH K	SPACING R	D	COUNTERBORE d	h
LPT-1025	0.138 (3.5)	0.551 (14)	2-56	0.138 (3.5)	0.138 (3.5)	0.155 (3.9)	0.101 (2.6)	.100 (2.5)
LPT-1035	0.138 (3.5)	—	—	—	0.197 (5)	—	—	.100 (2.5)
LPT-1045	0.492 (12.5)	—	—	—	0.138 (3.5)	—	—	.100 (2.5)
LPT-1055	0.492 (12.5)	—	—	—	0.138 (3.5)	—	C'BORE FOR 2-56	.100 (2.5)
LPT-1065	0.492 (12.5)	—	—	—	0.197 (5)	—	—	.100 (2.5)
LPT-1075	0.886 (22.5)	—	—	—	0.197 (5)	—	—	.100 (2.5)
LPT-1085	0.492 (12.5)	—	—	—	0.197 (5)	—	—	.100 (2.5)
LPT-2035	0.138 (3.5)	0.866 (22)	6-32	0.217 (5.5)	0.197 (5)	0.241 (6.1)	0.157 (4)	.150 (3.8)
LPT-2050	0.138 (3.5)	—	—	—	0.295 (7.5)	—	—	.150 (3.8)
LPT-2065	0.689 (17.5)	—	—	—	0.197 (5)	—	C'BORE FOR 6-32	.150 (3.8)
LPT-2080	0.689 (17.5)	—	—	—	0.197 (5)	—	—	.150 (3.8)
LPT-2095	0.689 (17.5)	—	—	—	0.197 (5)	—	—	.150 (3.8)
LPT-2110	1.280 (32.5)	—	—	—	0.295 (7.5)	—	—	.150 (3.8)
LPT-2125	0.689 (17.5)	—	—	—	0.295 (7.5)	—	—	.150 (3.8)
LPT-3055	0.295 (7.5)	1.181 (30)	10-32	0.295 (7.5)	0.295 (7.5)	0.327 (8.3)	0.204 (5.2)	.205 (5.2)
LPT-3080	0.295 (7.5)	—	—	—	0.236 (6)	—	—	.205 (5.2)
LPT-3105	1.083 (27.5)	—	—	—	0.295 (7.5)	—	C'BORE FOR 10-32	.205 (5.2)
LPT-3130	1.083 (27.5)	—	—	—	0.295 (7.5)	—	—	.205 (5.2)
LPT-3155	1.083 (27.5)	—	—	—	0.295 (7.5)	—	—	.205 (5.2)
LPT-3180	2.067 (52.5)	—	—	—	0.295 (7.5)	—	—	.205 (5.2)
LPT-3205	1.083 (27.5)	—	—	—	0.295 (7.5)	—	—	.205 (5.2)

Dimensions in inches (mm)

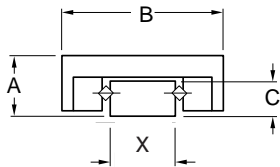

CARRIAGE MOUNTING DIMENSIONS

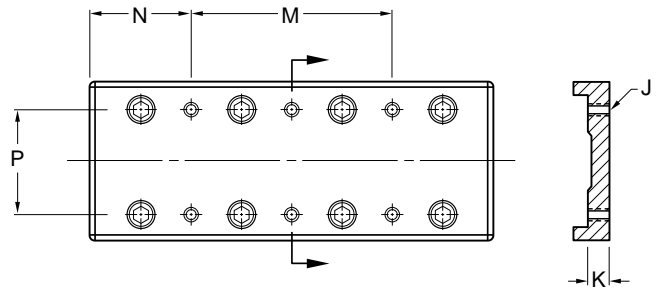

Profile Dimensions				
SERIES	HEIGHT A ±0.004 (0.1)	WIDTH B ±0.004 (0.1)	BASE THICKNESS C	BASE WIDTH X
LPT-1000	0.315 (8)	0.788 (20)	0.158 (4)	.259 (6.6)
LPT-2000	0.472 (12)	1.181 (30)	0.236 (6)	.472 (12)
LPT-3000	0.630 (16)	1.575 (40)	0.315 (8)	.629 (16)

Dimensions in inches (mm)

Crossed Roller Rail Sets

6 Reasons to choose Del-Tron[®] Crossed Roller Rail Sets

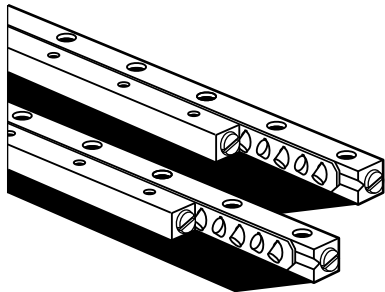

1. **Versatile-** May be adapted to your own base and carriage design.
2. **Rugged-** Hardened steel v-grooved rails and rollers withstand heavy loads and impacts.
3. **Corrosion Resistant-** 400 series Stainless steel available from stock
4. **High Accuracy-** Parallelism of 2 microns (0.00008") over 4 inches.
5. **Easy To Use-** Standard threaded and counterbored mounting holes allow access from either side.
6. **Interchangeable-** Form, fit and functional replacement for other manufacturer's rails.

Del-Tron[®] Crossed Roller Rail Sets

Crossed Roller Linear Bearings are compact, precision bearings that can support and guide high loads with high accuracy and repeatability, low friction, and low starting force. A complete range of sizes is supplied for use in precision machine tools, measuring instruments, assembly fixtures, medical instruments, and anywhere linear or reciprocating motion with high reliability and long life is required.

Construction

Each bearing consists of a pair of hardened steel ways containing 90° vee grooves, and a row of alternately crossed cylindrical rollers. The hardened steel rollers are captive in a stainless steel cage for easy handling and assembly and permanent alignment. The ways are installed face to face by the user, with the rollers between the vee grooves.

400 series Stainless Steel also available.

Application

Bearings are normally supplied and installed in sets of two to form an assembly that can support their rated load in any direction or orientation, and can be preloaded to eliminate side play.

Mounting and banking surfaces must be smooth and flat, and accurately parallel, coplanar, or perpendicular respectively to achieve maximum accuracy. Preload forces must be evenly distributed. Dirt and dust must be excluded. Lubrication required depends on the application, ranging from light grease or oil at the time of installation for low speeds (less than 50 inches/min.) and occasional movement to continuous oil bath or mist at 1200 inches/min.

Ratings and Specifications

Load ratings in the tables are dynamic ratings for each set. Ratings are based on theoretical data, proper installation, appropriate lubrication, and a predicted life of 10 million inches. Ratings are suggested only, based on standard and typical industry practice, and cannot be guaranteed. Life can be increased approximately 10 times by operating a given bearing at 1/2 its rated load, other factors being constant. Temperature of bearings must not exceed 100°C (212°F), even for short periods, since this will reduce hardness and result in significantly reduced load capacity and working life.

ACCURACY

The accuracy of a slide is measured along its entire length, as illustrated in Fig 2, and expressed in terms of parallelism (Fig 1.) Actual accuracy achieved depends on proper installation.

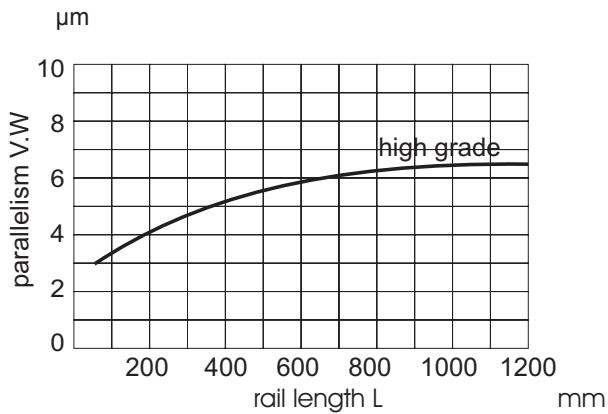

Fig. 1

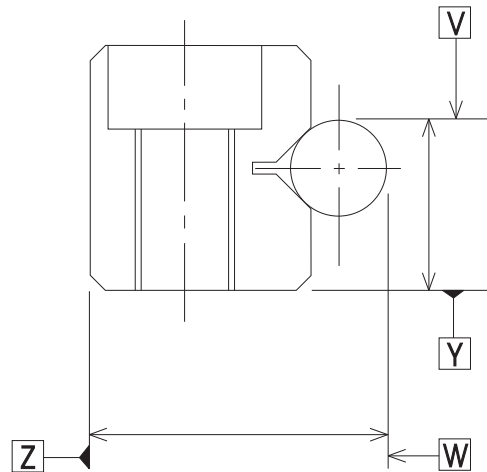
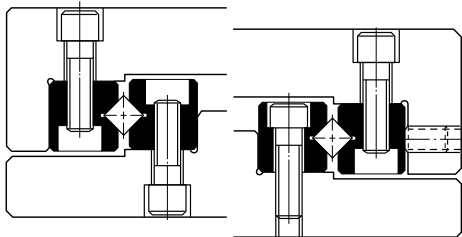
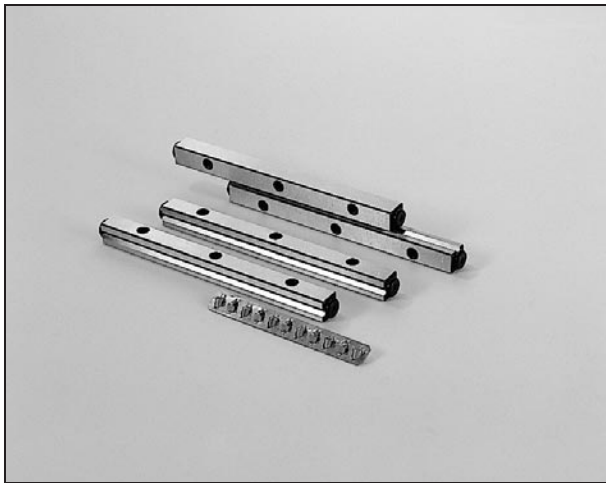

Fig. 2



Mounting holes in the way bars are threaded, and also counterbored to alternatively permit using the next smaller size screw with threaded mounting holes in the user's components.



Crossed Roller Rail Sets

Ordering

Order standard bearing sets from table by model number according to load and travel required

Each set consists of two complete bearings (4 rails, 2 roller cages, and end stops).

Delivery stock to 8 weeks.

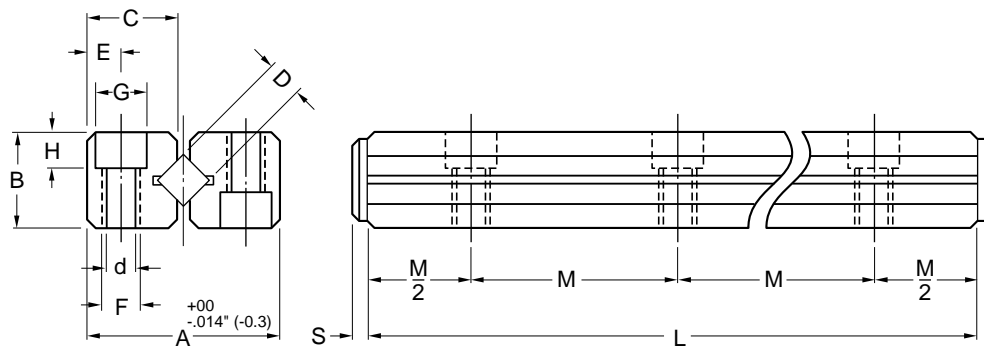

moment load ratings + load / life formulas. pg. 98

*Travel is 1/2 distance from center in either direction.												
MODEL	STAINLESS STEEL	NO. OF ROLLERS IN EACH RETAINER	LENGTH L	TRAVEL* T	NO. HOLES	RAIL SET LOAD CAPACITY LB	MODEL	NO. OF ROLLERS IN EACH RETAINER	LENGTH L	TRAVEL* T	NO. HOLES	RAIL SET LOAD CAPACITY LB
NB-1020	SS	5	0.788 (20)	0.473 (12)	2	44	NB-3225	31	8.858 (225)	5.315 (135)	9	682
NB-1030	SS	7	1.181 (30)	0.788 (20)	3	61	NB-3250	35	9.843 (250)	5.709 (145)	10	770
NB-1040	SS	10	1.575 (40)	1.063 (27)	4	88	NB-3275	38	10.827 (275)	6.496 (165)	11	836
NB-1050	SS	13	1.969 (50)	1.260 (32)	5	114	NB-3300	42	11.811 (300)	6.890 (175)	12	924
NB-1060	SS	16	2.362 (60)	1.457 (37)	6	140	NB-3325	45	12.795 (325)	7.677 (195)	13	990
NB-1070	SS	19	2.756 (70)	1.654 (42)	7	167	NB-3350	49	13.780 (350)	8.071 (205)	14	1,078
NB-1080	SS	21	3.150 (80)	1.969 (50)	8	184						
NB-2030	SS	5	1.181 (30)	0.709 (18)	2	66	NB-4080	7	3.150 (80)	2.283 (58)	2	308
NB-2045	SS	8	1.772 (45)	0.945 (24)	3	105	NB-4120	11	4.725 (120)	3.228 (82)	3	484
NB-2060	SS	11	2.362 (60)	1.181 (30)	4	145	NB-4160	15	6.299 (160)	4.134 (105)	4	660
NB-2075	SS	13	2.953 (75)	1.732 (44)	5	171	NB-4200	19	7.874 (200)	5.118 (130)	5	836
NB-2090	SS	16	3.544 (90)	1.969 (50)	6	211	NB-4240	23	9.449 (240)	5.905 (175)	6	1,012
NB-2105	SS	18	4.134 (105)	2.520 (64)	7	237	NB-4280	27	11.024 (280)	6.890 (175)	7	1,188
NB-2120	SS	21	4.725 (120)	2.756 (70)	8	277	NB-4320	31	12.598 (320)	7.874 (200)	8	1,364
NB-2135	SS	23	5.315 (135)	3.307 (84)	9	303	NB-4360	35	14.173 (360)	8.858 (225)	9	1,540
NB-2150	SS	26	5.906 (150)	3.544 (90)	10	343	NB-4400	39	15.748 (400)	9.843 (250)	10	1,716
NB-2165	SS	29	6.496 (165)	3.740 (95)	11	382	NB-4440	43	17.323 (440)	10.630 (270)	11	1,892
NB-2180	SS	32	7.087 (180)	3.937 (100)	12	422	NB-4480	47	18.898 (480)	11.614 (295)	12	2,068
NB-3050	SS	7	1.969 (50)	1.102 (28)	2	154	NB-6100	8	3.937 (100)	2.165 (55)	2	704
NB-3075	SS	10	2.953 (75)	1.890 (48)	3	220	NB-6150	12	5.906 (150)	3.346 (85)	3	1,056
NB-3100	SS	14	3.937 (100)	2.283 (58)	4	308	NB-6200	16	7.874 (200)	4.724 (120)	4	1,408
NB-3125	SS	17	4.921 (125)	3.071 (78)	5	374	NB-6250	20	9.843 (250)	5.906 (150)	5	1,760
NB-3150	SS	21	5.906 (150)	3.464 (88)	6	462	NB-6300	24	11.811 (300)	7.283 (185)	6	2,112
NB-3175	SS	24	6.890 (175)	4.134 (105)	7	528	NB-6350	28	13.780 (350)	8.465 (215)	7	2,464
NB-3200	SS	28	7.874 (200)	4.528 (115)	8	616	NB-6400	32	15.748 (400)	9.646 (245)	8	2,816

Please specify (SS) for Stainless Steel

SERIES	Profile Dimensions					Mounting Dimensions						
	A	B	C	D	S	M	E	F*	J**	d	G	H
NB-1	0.335 (8.5)	0.158 (4.0)	0.154 (3.9)	0.059 (1.5)	0.059 (1.5)	0.3937 (10)	0.0709 (1.8)	M2	#0	0.065 (1.65)	0.118 (3.0)	0.055 (1.4)
NB-2	0.473 (12)	0.236 (6.0)	0.217 (5.5)	0.079 (2.0)	0.079 (2.0)	0.591 (15)	0.0984 (2.5)	M3	#2	0.100 (2.55)	0.173 (4.4)	0.079 (2.0)
NB-3	0.708 (18)	0.315 (8.0)	0.327 (8.3)	0.118 (3.0)	0.079 (2.0)	0.9843 (25)	0.1378 (3.5)	M4	#4	0.130 (3.30)	0.236 (6.0)	0.122 (3.1)
NB-4	0.866 (22)	0.433 (11)	0.402 (10.2)	0.158 (4.0)	0.079 (2.0)	1.5748 (40)	0.1772 (4.5)	M5	#8	0.169 (4.3)	0.315 (8.0)	0.165 (4.2)
NB-6	1.221 (31)	0.591 (15)	0.559 (14.2)	0.236 (6.0)	0.118 (3.0)	1.9685 (50)	0.236 (6.0)	M6	#10	0.205 (5.2)	0.374 (9.5)	0.205 (5.2)

*Thread Size **Hole F clears cap screw for through mounting.

Modifying Length of Travel

For a given length of bearing way, since there is no slip at any load, both length of travel and load capacity depend on the number of rollers and their pitch. The number of rollers supplied with each standard bearing set provides a travel distance of approximately 60% of the way length (see page 56). In some cases (e.g., when mounting space is restricted)

it may be practical to increase travel at the expense of load capacity by removing one or more rollers instead of selecting a longer bearing. Since travel extends symmetrically around the mean position, the travel increase is twice the pitch for each roller removed. Similarly, the load capacity for the set (page 56) is reduced by twice the load capacity per roller.

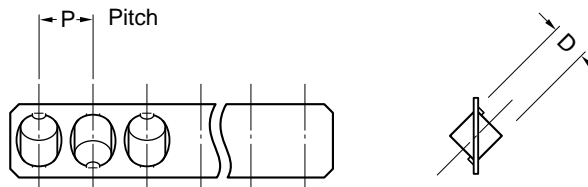

ROLLER SIZE	ROLLER DIAMETER (D) in (mm)	ROLLER DISTANCE (P) in (mm)	INCREASE OF TRAVEL FOR EACH ROLLER CUT-OFF in (mm)	ROLLER LOAD CARRYING CAP. PER ROLLER lbs (kg)
NB-1	0.059 (1.5)	0.098 (2.5)	.197 (5)	8.8 (4)
NB-2	0.079 (2)	.158 (4)	.316 (8)	13.2 (6)
NB-3	.118 (3)	.197 (5)	.394 (10)	22 (10)
NB-4	.158 (4)	.275 (7)	.550 (14)	44 (20)
NB-6	.236 (6)	.334 (8.5)	.668 (17)	88 (40)

Anti-Creep Crossed Roller Rail Sets

6 Reasons to choose Del-Tron® Anti-Creep Crossed Roller Rail Sets

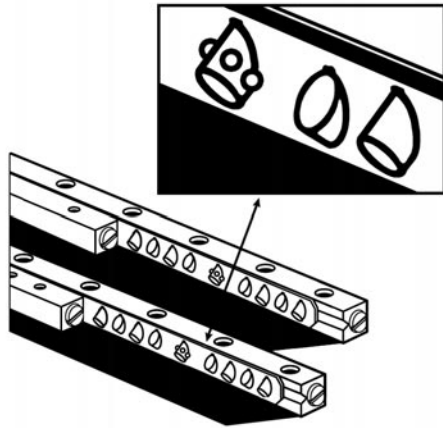

1. Designed for vertical applications and cantilevered loads.
2. Rugged- Hardened steel V-grooved rails and rollers withstand heavy loads.
3. Versatile- May be integrated into your own design.
4. High Accuracy- Parallelism of 3 microns (0.00012") over 4 inches.
5. Easy to use- Standard threaded and counterbored mounting holes allow access from either side.
6. Interchangeable- Form, fit and functional replacement for other manufacturer's Rail sets.

Del-Tron® Anti-Creep Crossed Roller Rail Sets

The Anti-Creep crossed roller rail system is based on a new concept to prevent roller cage slippage during operation. This system allows you to mount the rail set in any orientation while maintaining direct roller contact to the rail surface eliminating roller cage creep. This system is ideal for vertical applications and where high acceleration and deceleration forces are present.

Construction

Each bearing set contains four V-grooved Rails, eight end screws, and two Anti-Creep crossed roller retainers. The Anti-Creep crossed roller retainers utilize a studded roller and detented rail to prevent the migration of the retainer due to vertical and cantilevered load applications.

Application

Bearings are normally supplied and installed in sets of two to form an assembly that can support their rated load in any direction or orientation, and can be preloaded to eliminate side play.

Mounting and banking surfaces must be smooth and flat, and accurately parallel, coplanar, or perpendicular respectively to achieve maximum accuracy. Preload forces must be evenly distributed. Dirt and dust must be excluded. Lubrication required depends on the application, ranging from light grease or oil at the time of installation for low speeds (less than 50 inches/min.) and occasional movement to continuous oil bath or mist at 1200 inches/min.

RATINGS AND SPECIFICATIONS

Load ratings in the tables are dynamic ratings for each set. Ratings are based on theoretical data, proper installation, appropriate lubrication, and a predicted life of 10 million inches. Ratings are suggested only, based on standard and typical industry practice, and cannot be guaranteed. Life can be increased approximately 10 times by operating a given bearing at 1/2 its rated load, other factors being constant. Temperature of bearings must not exceed 82°C (180°F), even for short periods, since this will reduce hardness and result in significantly reduced load capacity and working life.

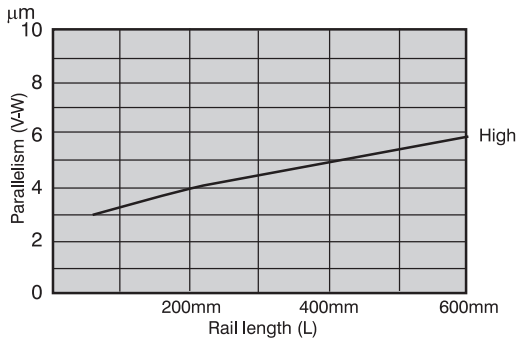
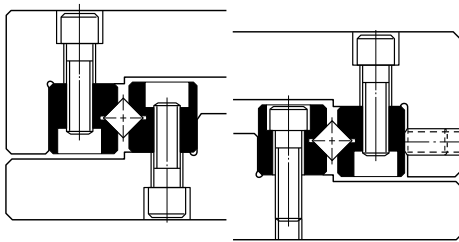
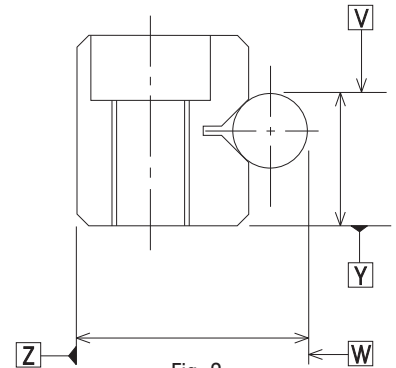

Fig. 1

ACCURACY

The accuracy of a slide is measured along its entire length, as illustrated in Fig 2, and expressed in terms of parallelism (Fig 1.) Actual accuracy achieved depends on proper installation.



Mounting holes in the way bars are threaded, and also counterbored to alternatively permit using the next smaller size screw with threaded mounting holes in the user's components.

INSTALLATION PROCEDURE

Note:

- * Provide external mechanical stoppers.
- * Set the movement to be less than the specified stroke.

- (1) Remove burrs, scratches, and dust from the rail mounting surface of the table and bed, and be careful to prevent contamination during assembly.
- (2) Apply low-viscosity oil to the contact surfaces, and align the table and the bed. (Figure 10a)
- (3) Set the reference surface shown in Figure 4 onto the mounting surface with the rails assembled. Set the table in the center position, and tighten the adjustment screws lightly so that almost no gap remains. (Figure 10b)
- (4) Keep the table in the center, tighten the rail mounting bolts lightly, loosen the end pieces of both end faces, and remove the fastening plate. Following this, firmly retighten the end pieces.
- (5) While maintaining the conditions of (4), gently move the assembly through its stroke being certain to check that the specified stroke length has been secured, and that there is no problem with the operation, or any other irregularity.
- (6) Move the table to the center and tighten only the adjustment screws on the R-retainer with the recommended tightening torque as shown in Table 3. (Figure 10c)
- (7) Gently move the table to one stroke end, and check that the table has surely come into contact with the external mechanical stopper. Following this, tighten the adjustment screws on the R-retainer in the same manner as (6). (Figure 10d)
- (8) Move the table to the opposite stroke end, and tighten in the same manner as (6). (Figure 10e)
- (9) Fasten the mounting bolts on rails 1, 2, and 3 by tightening with the recommended torque shown in Table 4. (Figure 10f)
- (10) Set the dial indicators to the center of the table and to the side (reference surface) of the table. (Figure 10g)
- (11) Perform the final preload adjustment. While moving the table back and forth, repeat steps (6) and (7) until the dial indicators show a minimum deviation.
- (12) Finally, securely fasten rail 4, which has been provisionally mounted, using the recommended torque. As with the adjustment screws, successively tighten the mounting bolts on the R-retainer while moving the table.

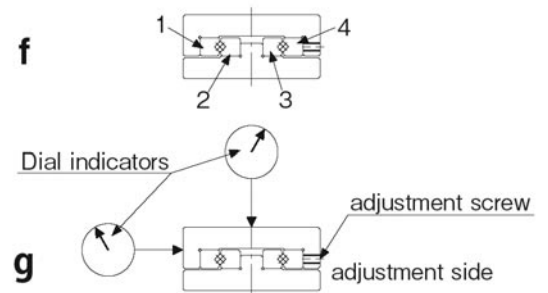
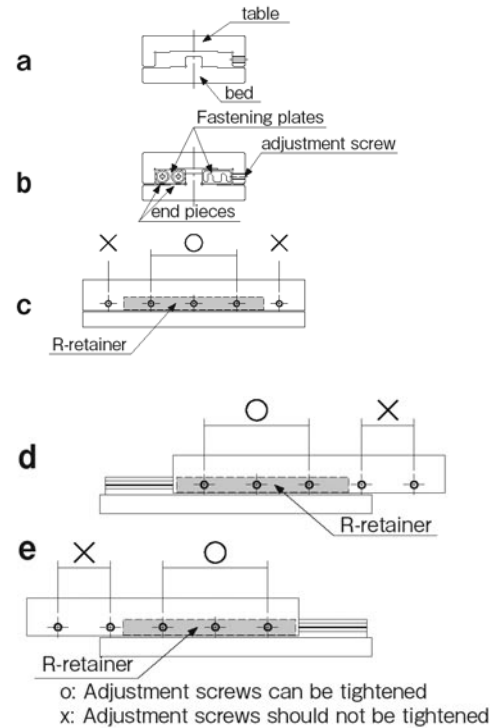

Anti-Creep Crossed Roller Rail Sets

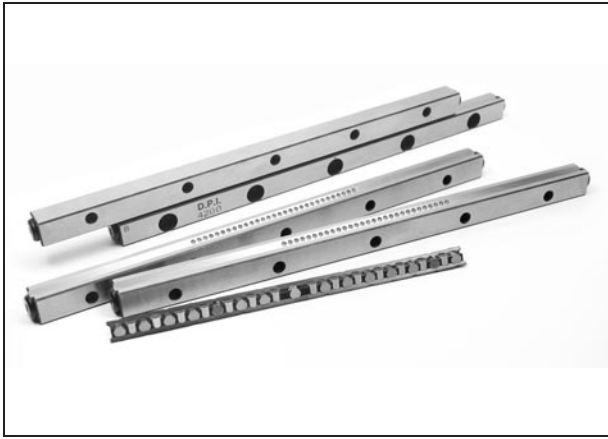

Ordering

Order standard bearing sets from table by model number according to load and travel required

**Each set consists of two complete bearings (4 rails, 2 roller cages, and end stops).
Delivery stock to 8 weeks.**

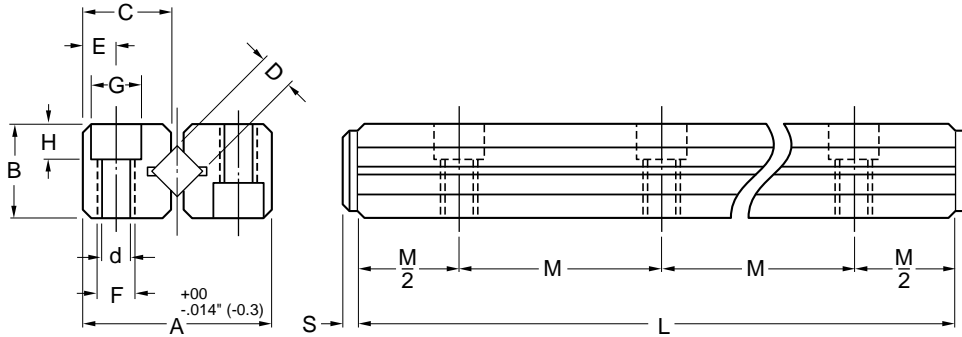

moment load ratings + load / life formulas. pg. 98

*Travel is 1/2 distance from center in either direction.											
MODEL	NO. OF ROLLERS IN EACH RETAINER	LENGTH L	TRAVEL* T	NO. HOLES	RAIL SET LOAD CAPACITY LB	MODEL	NO. OF ROLLERS IN EACH RETAINER	LENGTH L	TRAVEL* T	NO. HOLES	RAIL SET LOAD CAPACITY LB
NB-2030-AC	5	1.181 (30)	0.709 (18)	2	66	NB-3225-AC	43	8.858 (225)	5.905 (150)	9	682
NB-2045-AC	9	1.772 (45)	0.984 (25)	3	105	NB-4080-AC	9	3.150 (80)	2.362 (60)	2	308
NB-2060-AC	15	2.362 (60)	1.181 (30)	4	145	NB-4120-AC	17	4.725 (120)	2.952 (75)	3	484
NB-2075-AC	19	2.953 (75)	1.574 (40)	5	171	NB-4160-AC	23	6.299 (160)	4.134 (105)	4	660
NB-2090-AC	23	3.544 (90)	1.969 (50)	6	211	NB-4200-AC	29	7.874 (200)	5.118 (130)	5	836
NB-2105-AC	27	4.134 (105)	2.559 (65)	7	237	NB-4240-AC	37	9.449 (240)	6.629 (143)	6	1,012
NB-2120-AC	33	4.725 (120)	2.756 (70)	8	277	NB-4280-AC	43	11.024 (280)	6.692 (170)	7	1,188
NB-2135-AC	39	5.315 (135)	3.149 (80)	9	303	NB-6100-AC	9	3.937 (100)	2.165 (63)	2	704
NB-2150-AC	41	5.906 (150)	3.544 (90)	10	343	NB-6150-AC	15	5.906 (150)	3.346 (85)	3	1,056
NB-2165-AC	47	6.496 (165)	3.740 (95)	11	382	NB-6200-AC	19	7.874 (200)	5.314 (135)	4	1,408
NB-2180-AC	51	7.087 (180)	3.937 (100)	12	422	NB-6250-AC	25	9.843 (250)	6.220 (158)	5	1,760
NB-3050-AC	9	1.969 (50)	0.984 (25)	2	154	NB-6300-AC	31	11.811 (300)	7.086 (180)	6	2,112
NB-3075-AC	13	2.953 (75)	1.890 (48)	3	220	NB-6350-AC	35	13.780 (350)	9.055 (230)	7	2,464
NB-3100-AC	19	3.937 (100)	2.362 (60)	4	308	NB-6400-AC	39	15.748 (400)	10.83 (275)	8	2,816
NB-3125-AC	23	4.921 (125)	3.267 (83)	5	374						
NB-3150-AC	29	5.906 (150)	3.543 (90)	6	462						
NB-3175-AC	35	6.890 (175)	4.055 (103)	7	528						
NB-3200-AC	41	7.874 (200)	4.448 (113)	8	616						

SERIES	Profile Dimensions					Mounting Dimensions						
	A	B	C	D	S	M	E	F*	J**	d	G	H
NB-2-AC	0.473 (12)	0.236 (6.0)	0.217 (5.5)	0.079 (2.0)	0.079 (2.0)	0.591 (15)	0.0984 (2.5)	M3	#2	0.100 (2.55)	0.173 (4.4)	0.079 (2.0)
NB-3-AC	0.708 (18)	0.315 (8.0)	0.327 (8.3)	0.118 (3.0)	0.079 (2.0)	0.9843 (25)	0.1378 (3.5)	M4	#4	0.130 (3.30)	0.236 (6.0)	0.122 (3.1)
NB-4-AC	0.866 (22)	0.433 (11)	0.402 (10.2)	0.158 (4.0)	0.079 (2.0)	1.5748 (40)	0.1772 (4.5)	M5	#8	0.169 (4.3)	0.315 (8.0)	0.165 (4.2)
NB-6-AC	1.221 (31)	0.591 (15)	0.559 (14.2)	0.236 (6.0)	0.118 (3.0)	1.9685 (50)	0.236 (6.0)	M6	#10	0.205 (5.2)	0.374 (9.5)	0.205 (5.2)

*Thread Size

**Hole F clears cap screw for through mounting.

Crossed Roller Slide Tables (Aluminum)

6 Reasons to choose Del-Tron[®] Crossed Roller Slide Tables (Aluminum)

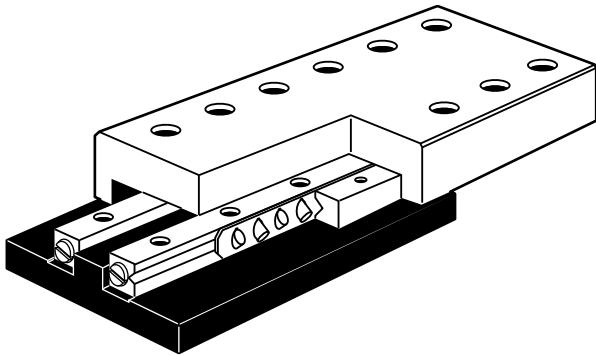

1. **High accuracy and load capacity.**
Precision ground V grooved ways and rollers.
2. **Withstands force in any direction.**
Alternately crossed rollers 45° angle.
3. **Easy installation.** Threaded mounting holes in standard pattern.
4. **400 series Stainless steel models available.** (Rails only)
5. **Lightweight aluminum base and carriage.**
6. **Interchangeable with other manufacturer's slides.**

Del-Tron[®] Crossed Roller Slide Tables

Our Aluminum crossed roller slide tables offer low cost and lightweight aluminum body construction to support heavy loads with low friction and precision linear motion. Select from over 45 standard sizes for use in a wide range of applications - precision instruments, office and communications equipment, surface grinders, tool grinders, and assembly fixtures, as examples.

Factory assembled and ready to install, each positioning table consists of an aluminum base and an aluminum carriage, both precision milled, and a pair of hardened steel linear bearings. Counterbored clearance holes, in base, permit easy mounting. Threaded holes, closely spaced in carriage, permit attaching your components without additional machining. Factory preloaded bearings eliminate side play. Internal stops, in the form of projecting screw heads between the underside of the carriage and base, protect bearings from over travel during handling.

Mount on flat surfaces to provide full support to the base. Loads stated, may be applied in any direction. Load values are calculated for weights evenly distributed on your positioning table. For full life of tables, we recommend careful calculation of moments and cantilevered loads.

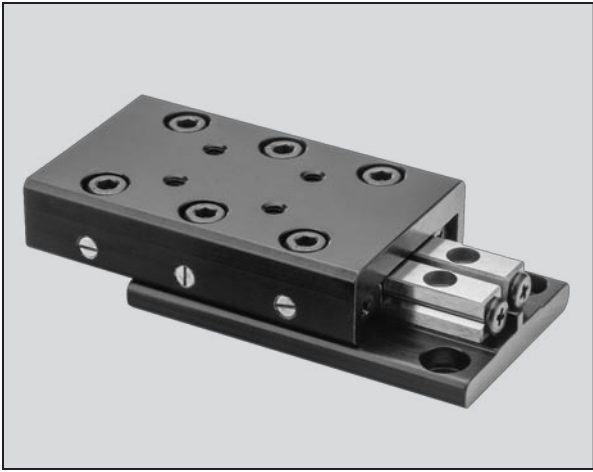

Crossed Roller Slide Tables (Aluminum)

Stainless Steel Models Available

For applications where particulate contamination caused by corrosion must be reduced, Del-Tron offers Aluminum crossed roller slide tables equipped with corrosion-resistant, stainless steel, crossed roller linear bearings.

TO ORDER:

Add SS to model number before "A". For example:
NBT-4085SSA

moment load ratings + load / life formulas. pg. 99

*Travel is 1/2 distance from center in either direction.

MODEL	STAINLESS STEEL	TRAVEL* T	LENGTH L	LOAD CAPACITY LBF (kgf)	BASE MOUNTING HOLES (COUNTERBORED)			CARRIAGE MOUNTING HOLES (THREADED)	
					NO. HOLES	U SPACING	W SPACING	NO. HOLES	SPACING M
NBT-1050A	SS	1.00	1.969 (50)	95 (43)	4	1.575 (40)	—	4	1 x .5906 (15)
NBT-1065A	SS	1.50	2.559 (65)	113 (51)	4	2.165 (55)	—	6	2 x .5906 (15)
NBT-1080A	SS	2.00	3.150 (80)	144 (65)	8	2.756 (70)	1.575 (40)	8	3 x .5906 (15)
NBT-1095A	SS	2.50	3.740 (95)	161 (73)	8	3.346 (85)	2.165 (55)	10	4 x .5906 (15)
NBT-1125A	SS	3.00	4.921 (125)	197 (89)	8	4.528 (115)	3.346 (85)	14	6 x .5906 (15)
NBT-2035A-18	SS	0.71	1.378 (35)	66 (30)	4	0.984 (25)	—	2	—
NBT-2050A	SS	1.00	1.969 (50)	96 (44)	4	1.575 (40)	—	4	1 x .5906 (15)
NBT-2050A-30	SS	1.18	1.969 (50)	96 (44)	4	1.575 (40)	—	4	1 x .5906 (15)
NBT-2065A	SS	1.50	2.559 (65)	114 (52)	4	2.165 (55)	—	6	2 x .5906 (15)
NBT-2065A-40	SS	1.58	2.559 (65)	114 (52)	4	2.165 (55)	—	6	2 x .5906 (15)
NBT-2080A-50	SS	1.97	3.150 (80)	145 (66)	8	2.756 (70)	1.575 (40)	8	3 x .5906 (15)
NBT-2080A	SS	2.00	3.150 (80)	145 (66)	8	2.756 (70)	1.575 (40)	8	3 x .5906 (15)
NBT-2095A-60	SS	2.36	3.740 (95)	162 (74)	8	3.346 (85)	2.165 (55)	10	4 x .5906 (15)
NBT-2095A	SS	2.50	3.740 (95)	162 (74)	8	3.346 (85)	2.165 (55)	10	4 x .5906 (15)
NBT-2110A-70	SS	2.76	4.331 (110)	187 (85)	8	3.937 (100)	2.756 (70)	12	5 x .5906 (15)
NBT-2125A	SS	3.00	4.921 (125)	198 (90)	8	4.528 (115)	3.346 (85)	14	6 x .5906 (15)
NBT-2125A-80	SS	3.15	4.921 (125)	198 (90)	8	4.528 (115)	3.346 (85)	14	6 x .5906 (15)
NBT-2155A-100	SS	3.94	6.102 (155)	317 (144)	8	5.708 (145)	4.527 (115)	18	8 x .5906 (15)
NBT-2185A-120	SS	4.72	7.283 (185)	383 (174)	8	6.889 (175)	5.708 (145)	22	10 x .5906 (15)
NBT-3055A	SS	1.00	2.165 (55)	193 (88)	4	1.378 (35)	—	2	—
NBT-3055A-30	SS	1.18	2.165 (55)	193 (88)	4	1.378 (35)	—	2	—
NBT-3080A-45	SS	1.77	3.150 (80)	220 (100)	4	2.362 (60)	—	4	1 x .9843 (25)
NBT-3105A	SS	2.00	4.134 (105)	338 (154)	4	3.345 (85)	—	6	2 x .9843 (25)
NBT-3105A-60	SS	2.36	4.134 (105)	338 (154)	4	3.345 (85)	—	6	2 x .9843 (25)
NBT-3130A-75	SS	2.95	5.118 (130)	374 (170)	4	4.330 (110)	—	8	3 x .9843 (25)
NBT-3155A	SS	3.00	6.102 (155)	477 (217)	4	5.315 (135)	—	10	4 x .9843 (25)
NBT-3155A-90	SS	3.54	6.102 (155)	477 (217)	4	5.315 (135)	—	10	4 x .9843 (25)
NBT-3180A	SS	4.00	7.087 (180)	545 (248)	4	6.299 (160)	—	12	5 x .9843 (25)
NBT-3180A-105	SS	4.13	7.087 (180)	545 (248)	4	6.299 (160)	—	12	5 x .9843 (25)
NBT-3205A	SS	5.00	8.071 (205)	576 (262)	8	7.283 (185)	3.346 (85)	14	6 x .9843 (25)
NBT-3205A-130	SS	5.12	8.071 (205)	576 (262)	8	7.283 (185)	3.346 (85)	14	6 x .9843 (25)
NBT-3230A-155	SS	6.10	9.055 (230)	638 (290)	8	8.267 (210)	4.300 (110)	16	7 x .9843 (25)
NBT-3255A-180	SS	7.09	10.039 (255)	682 (310)	8	9.251 (235)	5.314 (135)	18	8 x .9843 (25)
NBT-3280A-205	SS	8.07	11.024 (280)	748 (340)	8	10.236 (260)	6.299 (160)	20	9 x .9843 (25)
NBT-3305A-230	SS	9.06	12.008 (305)	792 (360)	8	11.220 (285)	7.283 (185)	22	10 x .9843 (25)
NBT-4085A	SS	2.00	3.346 (85)	430 (196)	4	2.559 (65)	—	2	—
NBT-4125A	SS	3.00	4.921 (125)	600 (273)	4	4.134 (105)	—	4	1 x 1.575 (40)
NBT-4165A	SS	4.00	6.496 (165)	723 (329)	4	5.709 (145)	—	6	2 x 1.575 (40)
NBT-4205A	SS	5.00	8.071 (205)	870 (395)	4	7.283 (185)	—	8	3 x 1.575 (40)
NBT-4245A	SS	6.00	9.646 (245)	1016 (462)	4	8.858 (225)	—	10	4 x 1.575 (40)
NBT-6110A	SS	3.00	4.331 (110)	616 (280)	4	3.543 (90)	—	2	—
NBT-6160A	SS	4.00	6.300 (160)	1062 (483)	4	5.512 (140)	—	4	1 x 1.969 (50)
NBT-6260A	SS	6.00	10.24 (260)	1600 (728)	4	9.449 (240)	—	8	3 x 1.969 (50)
NBT-6360A	SS	9.00	14.17 (360)	2032 (924)	8	13.39 (340)	5.512 (140)	12	5 x 1.969 (50)

SERIES	Mounting Dimensions								
	CARRIAGE				BASE				
	SPACING		THREAD	DEPTH	SPACING		COUNTERBORE		
N	P	J	K	R	S	D	d	h	
NBT-1000A	0.689 (17.5)	0.394 (10)	4-40	0.177 (4.5)	0.197 (5)	0.866 (22)	0.198 (5)	0.125 (3.1)	.125 (3.2)
NBT-2000A	0.689 (17.5)	0.591 (15)	6-32	0.315 (8)	0.197 (5)	1.181 (30)	0.241 (6.1)	0.149 (3.7)	.145 (3.7)
NBT-3000A	1.083 (27.5)	0.984 (25)	10-32	0.413 (10.5)	0.394 (10)	1.575 (40)	0.328 (8.3)	0.197 (5)	.205 (5.2)
NBT-4000A	1.673 (42.5)	1.575 (40)	10-32	0.512 (13)	0.394 (10)	2.165 (55)	0.328 (8.3)	0.197 (5)	.205 (5.2)
NBT-6000A	2.165 (55)	1.969 (50)	1/4-20	0.630 (16)	0.394 (10)	2.362 (60)	0.406 (10.3)	0.266 (6.7)	.315 (8.0)

Dimensions in inches (mm)

Specifications:

Straight Line Accuracy
0.0001"/inch of travel

Positional Repeatability
0.0001"

Coefficient of Friction
0.003 typical

Construction
Aluminum carriage and base,
hardened steel crossed roller rail sets.
400 Series SS Rail Sets available.

Finish
Carriage: Aluminum, Base: Black
anodize

Ordering
Order standard slide tables from table
by model number according to load
and travel required.

Delivery stock to 6 weeks.

CARRIAGE MOUNTING DIMENSIONS

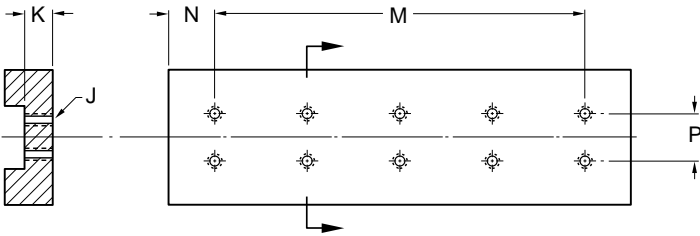

BASE MOUNTING DIMENSIONS

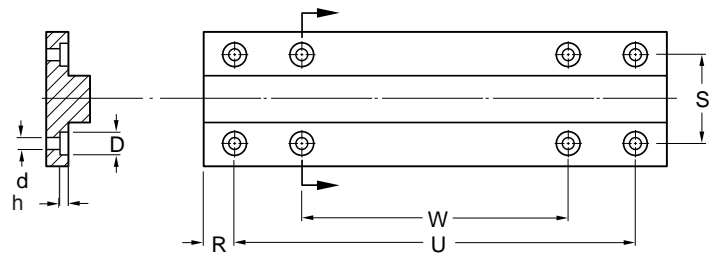

SERIES	Profile Dimensions		
	HEIGHT A ±.005 (0.13)	WIDTH B ±.010 (0.25)	BASE THICKNESS C
NBT-1000A	0.590 (15)	1.181 (30)	0.160 (4.1)
NBT-2000A	0.827 (21)	1.575 (40)	0.256 (6.5)
NBT-3000A	1.102 (28)	2.362 (60)	0.354 (9)
NBT-4000A	1.378 (35)	3.150 (80)	0.413 (10.5)
NBT-6000A	1.772 (45)	3.937 (100)	0.512 (13)

Dimensions in inches (mm)

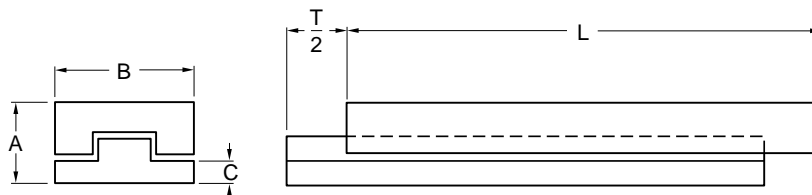

Anti-Creep Crossed Roller Slide Tables (Aluminum)

6 Reasons to choose Del-Tron® Anti-Creep Crossed Roller Slide Tables (Aluminum)

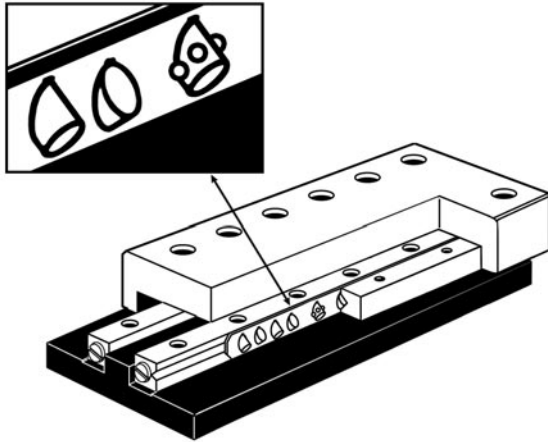

- 1. Anti-Creep Crossed Roller Technology.**
Ideal for vertical and cantilevered load applications.
- 2. High accuracy and load capacity.**
Precision V grooved rails and rollers.
- 3. Lightweight aluminum carriage and base design.**
- 4. Withstands force in any direction.**
Alternately crossed roller cage design.
- 5. Easy installation.** Threaded and counterbored mounting holes in standard pattern.
- 6. Interchangeable with other manufacturer's slides.**

Del-Tron® Anti-Creep Crossed Roller Slide Tables

The Anti-Creep crossed roller slide tables utilize our Anti-Creep crossed roller rail systems to prevent roller cage slippage during operation. This system allows you to mount the table in any orientation while maintaining direct roller contact to the rail surface eliminating roller cage creep. These tables are ideal for vertical applications and where high acceleration and deceleration forces are present.

Factory assembled and ready to install, each positioning table consists of an aluminum base and an aluminum carriage, both precision milled, and a pair of hardened steel linear bearings. Counterbored clearance holes, in base, permit easy mounting. Threaded holes, closely spaced in carriage, permit attaching your components without additional machining. Factory preloaded bearings eliminate side play. Internal stops, in the form of projecting screw heads between the underside of the carriage and base, protect bearings from over travel during handling.

Mount on flat surfaces to provide full support to the base. Loads stated, may be applied in any direction. Load values are calculated for weights evenly distributed on your positioning table. For full life of tables, we recommend careful calculation of moments and cantilevered loads.

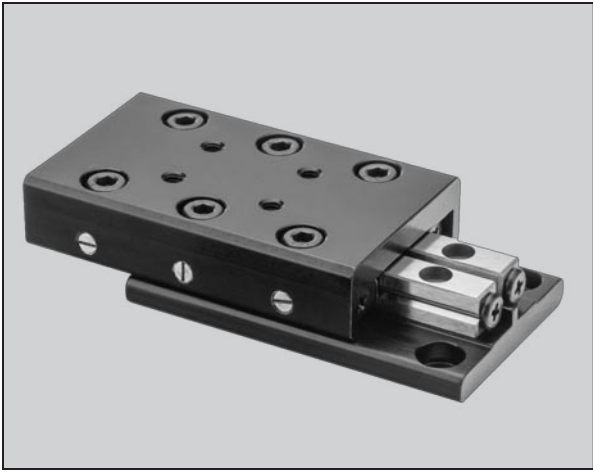

Anti-Creep Crossed Roller Slide Tables (Aluminum)

Stainless Steel Models Available

For applications where particulate contamination caused by corrosion must be reduced, Del-Tron offers Aluminum crossed roller positioning tables equipped with corrosion-resistant, stainless steel, crossed roller linear bearings.

TO ORDER:

Add SS to model number before "A". For example: NBT-4085SSA-AC

moment load ratings + load / life formulas. pg.99

*Travel is 1/2 distance from center in either direction.

MODEL	TRAVEL* T (mm)	LENGTH L	LOAD CAPACITY LBF (kgf)	BASE MOUNTING HOLES (COUNTERBORED)			CARRIAGE MOUNTING HOLES (THREADED)	
				NO. HOLES	SPACING		NO. HOLES	SPACING M
					U	W		
NBT-1050A-AC	0.98 (25)	1.969 (50)	95 (43)	4	1.575 (40)	—	4	1 x .5906 (15)
NBT-1065A-AC	1.18 (30)	2.559 (65)	113 (51)	4	2.165 (55)	—	6	2 x .5906 (15)
NBT-1080A-AC	1.57 (40)	3.150 (80)	144 (65)	8	2.756 (70)	1.575 (40)	8	3 x .5906 (15)
NBT-1095A-AC	1.96 (50)	3.740 (95)	161 (73)	8	3.346 (85)	2.165 (55)	10	4 x .5906 (15)
NBT-1125A-AC	2.75 (70)	4.921 (125)	197 (89)	8	4.528 (115)	3.346 (85)	14	6 x .5906 (15)
NBT-2035A-18-AC	0.71 (18)	1.378 (35)	66 (30)	4	0.984 (25)	—	2	—
NBT-2050A-AC	0.98 (25)	1.969 (50)	96 (44)	4	1.575 (40)	—	4	1 x .5906 (15)
NBT-2065A-AC	1.18 (30)	2.559 (65)	114 (52)	4	2.165 (55)	—	6	2 x .5906 (15)
NBT-2080A-AC	1.57 (40)	3.150 (80)	145 (66)	8	2.756 (70)	—	8	3 x .5906 (15)
NBT-2095A-AC	1.96 (50)	3.740 (95)	162 (74)	8	3.346 (85)	2.165 (55)	10	4 x .5906 (15)
NBT-2110A-70-AC	2.56 (65)	4.331 (110)	187 (85)	8	3.937 (100)	2.756 (70)	12	5 x .5906 (15)
NBT-2125A-AC	2.75 (70)	4.921 (125)	198 (90)	8	4.528 (115)	3.346 (85)	14	6 x .5906 (15)
NBT-2155A-100-AC	3.54 (90)	6.102 (155)	317 (144)	8	5.708 (145)	4.527 (115)	18	8 x .5906 (15)
NBT-2185A-120-AC	3.93 (100)	7.283 (185)	383 (174)	8	6.889 (175)	5.708 (145)	22	10 x .5906 (15)
NBT-3055A-AC	0.98 (25)	2.165 (55)	193 (88)	4	1.378 (35)	—	2	—
NBT-3080A-45-AC	1.89 (48)	3.150 (80)	220 (100)	4	2.362 (60)	—	4	1 x .9843 (25)
NBT-3105A-AC	2.36 (60)	4.134 (105)	338 (154)	4	3.345 (85)	—	6	2 x .9843 (25)
NBT-3130A-75-AC	3.27 (83)	5.118 (130)	374 (170)	4	4.330 (110)	—	8	3 x .9843 (25)
NBT-3155A-AC	3.54 (90)	6.102 (155)	477 (217)	4	5.315 (135)	—	10	4 x .9843 (25)
NBT-3180A-AC	4.05 (103)	7.087 (180)	545 (248)	4	6.299 (160)	—	12	5 x .9843 (25)
NBT-3205A-AC	4.45 (113)	8.071 (205)	576 (262)	8	7.283 (185)	3.346 (85)	14	6 x .9843 (25)
NBT-3230A-155-AC	5.90 (150)	9.055 (230)	638 (290)	8	8.267 (210)	4.300 (110)	16	7 x .9843 (25)
NBT-4085A-AC	2.36 (60)	3.346 (85)	430 (196)	4	2.559 (65)	—	2	—
NBT-4125A-AC	2.95 (75)	4.921 (125)	600 (273)	4	4.134 (105)	—	4	1 x 1.575 (40)
NBT-4165A-AC	4.13 (105)	6.496 (165)	723 (329)	4	5.709 (145)	—	6	2 x 1.575 (40)
NBT-4205A-AC	5.12 (130)	8.071 (205)	870 (395)	4	7.283 (185)	—	8	3 x 1.575 (40)
NBT-4245A-AC	5.63 (143)	9.646 (245)	1016 (462)	4	8.858 (225)	—	10	4 x 1.575 (40)
NBT-6110A-AC	2.48 (63)	4.331 (110)	616 (280)	4	3.543 (90)	—	2	—
NBT-6160A-AC	3.35 (85)	6.300 (160)	1062 (483)	4	5.512 (140)	—	4	1 x 1.969 (50)
NBT-6260A-AC	6.22 (158)	10.24 (260)	1600 (728)	4	9.449 (240)	—	8	3 x 1.969 (50)
NBT-6360A-AC	9.06 (230)	14.17 (360)	2032 (924)	8	13.39 (340)	5.512 (140)	12	5 x 1.969 (50)

SERIES	Mounting Dimensions								
	CARRIAGE				BASE				
	SPACING N	P	THREAD J	DEPTH K	SPACING R	S	COUNTERBORE D d		h
NBT-1000A-AC	0.689 (17.5)	0.394 (10)	4-40	0.177 (4.5)	0.197 (5)	0.866 (22)	0.198 (5)	0.125 (3.1)	.125 (3.2)
NBT-2000A-AC	0.689 (17.5)	0.591 (15)	6-32	0.315 (8)	0.197 (5)	1.181 (30)	0.241 (6.1)	0.149 (3.7)	.145 (3.7)
NBT-3000A-AC	1.083 (27.5)	0.984 (25)	10-32	0.413 (10.5)	0.394 (10)	1.575 (40)	0.328 (8.3)	0.197 (5)	.205 (5.2)
NBT-4000A-AC	1.673 (42.5)	1.575 (40)	10-32	0.512 (13)	0.394 (10)	2.165 (55)	0.328 (8.3)	0.197 (5)	.205 (5.2)
NBT-6000A-AC	2.165 (55)	1.969 (50)	1/4-20	0.630 (16)	0.394 (10)	2.362 (60)	0.406 (10.3)	0.266 (6.7)	.315 (8.0)

Dimensions in inches (mm)

Specifications:

Straight Line Accuracy
0.0001"/inch of travel

Positional Repeatability
0.0001"

Coefficient of Friction
0.003 typical

Construction
Aluminum carriage and base,
hardened steel crossed roller rail sets.

Finish
Carriage: Aluminum, Base: Black
anodize

Ordering
Order standard slide tables from table
by model number according to load
and travel required.

Delivery stock to 6 weeks.

CARRIAGE MOUNTING DIMENSIONS

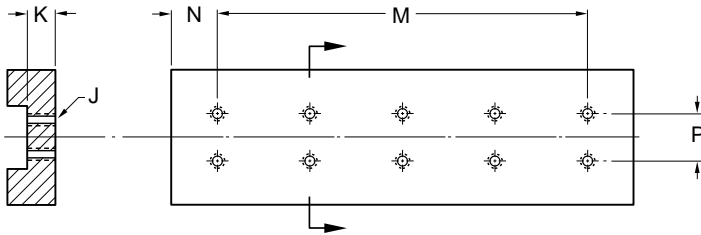

BASE MOUNTING DIMENSIONS

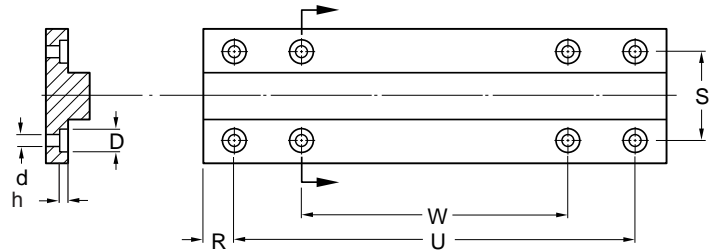

SERIES	Profile Dimensions		
	HEIGHT A ±.005 (0.13)	WIDTH B ±.010 (0.25)	BASE THICKNESS C
NBT-1000A-AC	0.590 (15)	1.181 (30)	0.160 (4.1)
NBT-2000A-AC	0.827 (21)	1.575 (40)	0.256 (6.5)
NBT-3000A-AC	1.102 (28)	2.362 (60)	0.354 (9)
NBT-4000A-AC	1.378 (35)	3.150 (80)	0.413 (10.5)
NBT-6000A-AC	1.772 (45)	3.937 (100)	0.512 (13)

Dimensions in inches (mm)

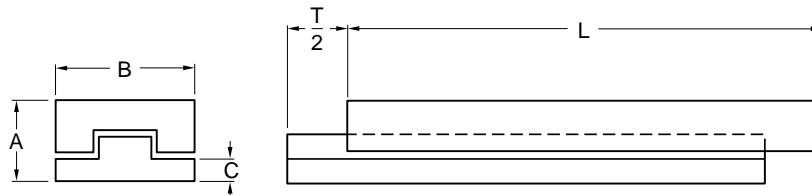

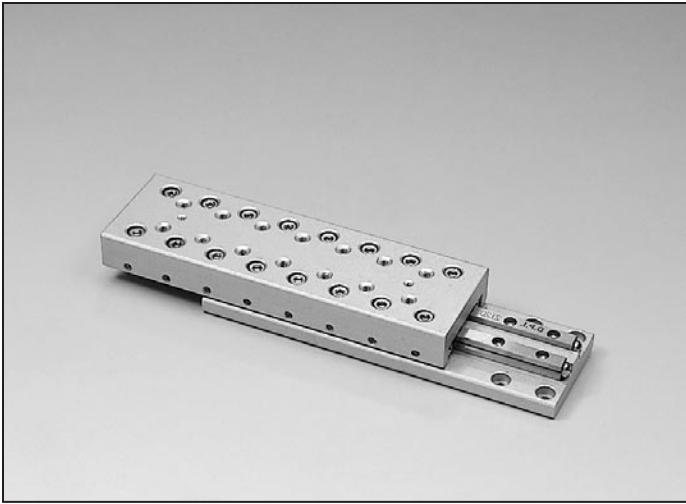

Inch Series Crossed Roller Slide Tables NBTA Type

This series of crossed roller tables offers the designer robust slide tables made to the same standards as our NBTA series but with inch type overall dimensions. Each cross section is designated by its width 2", 3", and 4". This series is interchangeable with those of other manufacturer's tables and is available from stock at competitive prices.

400 series Stainless Steel Models Available

For applications where particulate contamination caused by corrosion must be reduced, Del-Tron offers crossed roller slide tables equipped with corrosion-resistant, stainless steel, crossed roller linear bearings.

Base & carriage: aluminum
Rails, rollers, retainers & fasteners: stainless steel

TO ORDER:
Add SS to model number. For example: NBTA-221SS

moment load ratings + load / life formulas. pg. 99

MODEL	STAINLESS STEEL	TRAVEL* T	LENGTH L	LOAD CAPACITY LBF (kgf)	BASE MOUNTING HOLES (COUNTERBORED)			CARRIAGE MOUNTING HOLES (THREADED)	
					NO. HOLES	SPACING		NO. HOLES	SPACING M
						U	W		
NBTA-221	SS	1	2	154 (70)	4	1.000		2	Centered
NBTA-232	SS	2	3	198 (90)	4	2.000		4	1 x 1.000
NBTA-243	SS	3	4	264 (120)	4	3.000		6	2 x 1.000
NBTA-254	SS	4	5	308 (140)	4	4.000		8	3 x 1.000
NBTA-265	SS	5	6	374 (170)	4	5.000		10	4 x 1.000
NBTA-276	SS	6	7	418 (190)	4	6.000		12	5 x 1.000
NBTA-287	SS	7	8	462 (210)	8	7.000	5.000	14	6 x 1.000
NBTA-298	SS	8	9	528 (240)	8	8.000	6.000	16	7 x 1.000
NBTA-2109	SS	9	10	572 (259)	8	9.000	7.000	18	8 x 1.000
NBTA-21110	SS	10	11	638 (289)	8	10.000	8.000	20	9 x 1.000
NBTA-21211	SS	11	12	682 (309)	8	11.000	9.000	22	10 x 1.000
NBTA-332	SS	2	3	198 (90)	4	2.000		4	1 x 1.000
NBTA-343	SS	3	4	264 (120)	4	3.000		6	2 x 1.000
NBTA-354	SS	4	5	308 (140)	4	4.000		8	3 x 1.000
NBTA-365	SS	5	6	374 (170)	4	5.000		10	4 x 1.000
NBTA-376	SS	6	7	418 (190)	4	6.000		12	5 x 1.000
NBTA-387	SS	7	8	462 (210)	8	7.000	5.000	14	6 x 1.000
NBTA-398	SS	8	9	528 (240)	8	8.000	6.000	16	7 x 1.000
NBTA-3109	SS	9	10	572 (259)	8	9.000	7.000	18	8 x 1.000
NBTA-31110	SS	10	11	638 (289)	8	10.000	8.000	20	9 x 1.000
NBTA-31211	SS	11	12	682 (309)	8	11.000	9.000	22	10 x 1.000
NBTA-443	SS	3	4	528 (240)	4	3.000		6	2 x 1.000
NBTA-465	SS	5	6	792 (359)	4	5.000		10	4 x 1.000
NBTA-487	SS	7	8	1056 (479)	8	7.000	5.000	14	6 x 1.000
NBTA-4109	SS	9	10	1320 (599)	8	9.000	7.000	18	8 x 1.000
NBTA-41211	SS	11	12	1584 (719)	8	11.000	9.000	22	10 x 1.000
NBTA-41413	SS	13	14	1848 (838)	8	13.000	11.000	26	12 x 1.000
NBTA-41615	SS	15	16	2024 (918)	8	15.000	13.000	30	14 x 1.000

Profile Dimensions			
SERIES	HEIGHT A ±.005	WIDTH B ±.010	BASE THICKNESS C
NBTA-2	.980	2.000	.205
NBTA-3	1.250	3.000	.405
NBTA-4	1.440	4.000	.445

Specifications:

Straight Line Accuracy
0.0001"/inch of travel

Positional Repeatability
0.0001"

Coefficient of Friction
0.003 typical

Construction
Aluminum carriage and base, hardened steel crossed roller rail sets. 400 series stainless steel available.

Finish
Carriage: Clear anodize, Base: Clear anodize

Ordering
Order standard slide tables from table by model number according to load and travel required.

Delivery stock to 6 weeks.

SERIES	Mounting Dimensions									
	CARRIAGE				BASE					Screw Size
	SPACING N	SPACING P	THREAD J	DEPTH K	SPACING R	S	COUNTERBORE D	d	h	
NBTA-2	1.005	0.875	#8-32	0.330	0.496	1.500	0.275	0.185	.170	#8
NBTA-3	1.005	1.375	#10-32	0.330	0.496	2.375	0.330	0.204	.205	#10
NBTA-4	1.005	1.875	1/4-20	0.327	0.496	3.375	0.406	0.281	.312	#1/4

CARRIAGE MOUNTING DIMENSIONS

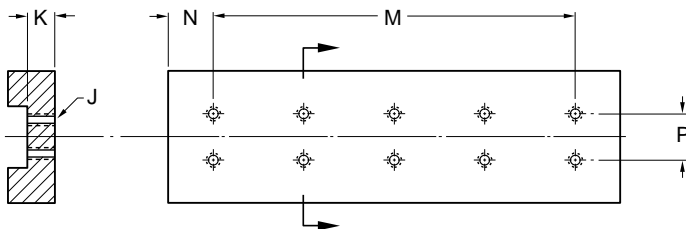

BASE MOUNTING DIMENSIONS

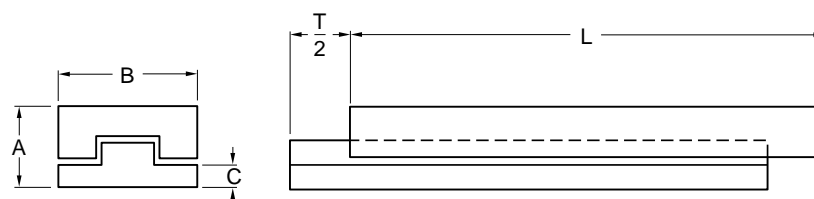
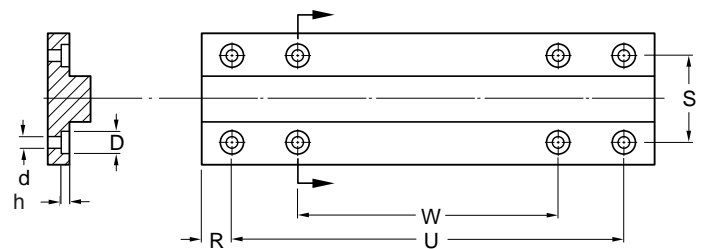

Crossed Roller Slide Tables (Steel)

6 Reasons to choose Del-Tron® Crossed Roller Slide Tables (Steel)

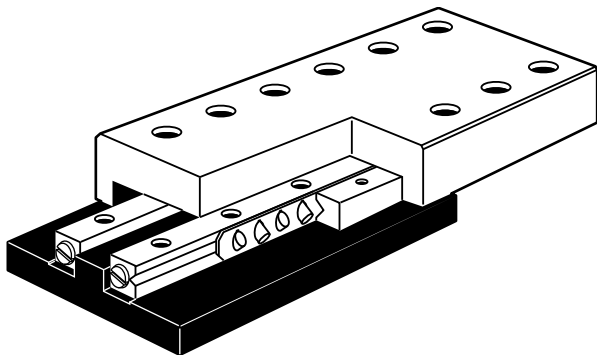

1. **High Accuracy - .00008" parallelism.**
2. **High Load Capacity - Crossed roller way construction handles loads up to 2,640 lb.**
3. **Interchangeable with other manufacturer's tables.**
4. **Low Friction - 0.003 coefficient of friction for smooth operation.**
5. **Standard Mounting - Holes provided.**
6. **Backlash Free - Factory preloaded for minimum axial play.**

Crossed Roller Slide Tables

Crossed Roller Slide Tables are factory assembled, and ready to install. They use Del-Tron® crossed roller bearings to provide very precise linear motion with low friction and high support stiffness for the load. A selection of more than 40 standard sizes is available for applications including precision instruments, office and communications equipment, surface grinders, tool grinders, assembly fixtures, and anywhere precise linear positioning is required.

Construction

Each slide table consists of a one piece base, a one piece carriage, and a pair of linear bearings. The bearings are factory preloaded to eliminate side play.

Counterbored clearance holes in the base permit easy mounting in your structure. Threaded holes in the carriage are closely spaced to permit attaching your components without additional machining in most cases.

Standard material for base and carriage is cold rolled steel, with black oxide finish.

Application

Mount on a flat surface to provide full support to the base.

Although it is seldom needed, the carriage surface can be machined or additional mounting holes can be added if the following precautions are observed:

1. Do not disassemble the table since reassembly and readjustment of the preloading require special procedures.
2. Protect the ways against entry of chips and debris.
3. Drill only blind holes through the carriage to avoid depositing chips inside the unit.
4. Avoid intersection with internal mounting or preloading screws.
5. Avoid clamping forces in excess of the rated load capacity.

Internal stops, in the form of projecting screw heads between the under side of the carriage and the base, are intended only to protect the bearings from over travel during handling. Provide separate stops appropriate for your load if needed.

The ends of the carriage contain tapped holes that permit easy attachment of way covers, bellows, or other shields to exclude dust and keep the ways clean.

Crossed Roller Slide Tables (Steel)

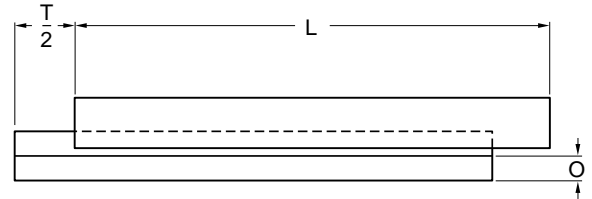
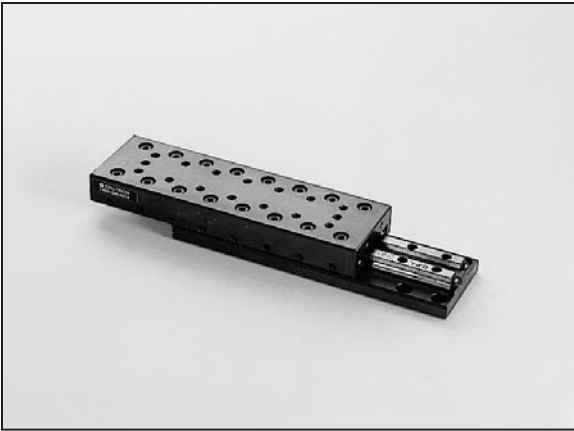

moment load ratings + load / life formulas. pg. 100

*Travel is 1/2 distance from center in either direction.

MODEL	TRAVEL* T	LENGTH L	LOAD CAPACITY LBF (kgf)	NO. HOLES	BASE MOUNTING HOLES (COUNTERBORED) SPACING					CARRIAGE MOUNTING HOLES (THREADED)	
					U	V	W	X	Y	NO. HOLES	SPACING M
NBT-1025	0.472 (12)	0.984 (25)	26 (12)	4	0.709 (18)	—	—	—	—	2	—
NBT-1035	0.709 (18)	1.378 (35)	35 (16)	4	1.102 (28)	—	—	—	—	4	1 × .3937 (10)
NBT-1045	0.984 (25)	1.772 (45)	44 (20)	4	1.496 (38)	—	—	—	—	6	2 × .3937 (10)
NBT-1055	1.260 (32)	2.165 (55)	57 (26)	8	1.890 (48)	—	1.102 (28)	—	—	8	3 × .3937 (10)
NBT-1065	1.575 (40)	2.559 (65)	70 (32)	8	2.283 (58)	—	1.496 (38)	—	—	10	4 × .3937 (10)
NBT-1075	1.772 (45)	2.953 (75)	79 (36)	8	2.677 (68)	—	1.890 (48)	—	—	12	5 × .3937 (10)
NBT-1085	1.969 (50)	3.346 (85)	88 (40)	8	3.071 (78)	—	2.283 (58)	—	—	14	6 × .3937 (10)
NBT-2035	0.709 (18)	1.378 (35)	88 (40)	4	0.984 (25)	—	—	—	—	2	—
NBT-2050	1.181 (30)	1.969 (50)	137 (63)	4	1.575 (40)	—	—	—	—	4	1 × .5906 (15)
NBT-2065	1.575 (40)	2.559 (65)	165 (75)	4	2.165 (55)	—	—	—	—	6	2 × .5906 (15)
NBT-2080	1.969 (50)	3.150 (80)	209 (95)	8	2.756 (70)	—	1.575 (40)	—	—	8	3 × .5906 (15)
NBT-2095	2.362 (60)	3.740 (95)	231 (105)	8	3.346 (85)	—	2.165 (55)	—	—	10	4 × .5906 (15)
NBT-2110	2.756 (70)	4.331 (110)	264 (120)	8	3.937 (100)	—	2.756 (70)	—	—	12	5 × .5906 (15)
NBT-2125	3.150 (80)	4.921 (125)	286 (130)	8	4.528 (115)	—	3.346 (85)	—	—	14	6 × .5906 (15)
NBT-2140	3.543 (90)	5.512 (140)	319 (145)	12	5.118 (130)	—	3.937 (100)	—	2.756 (70)	16	7 × .5906 (15)
NBT-2155	3.937 (100)	6.102 (155)	341 (155)	12	5.709 (145)	—	4.528 (115)	—	3.346 (85)	18	8 × .5906 (15)
NBT-2170	4.331 (110)	6.693 (170)	374 (170)	12	6.299 (160)	—	5.118 (130)	—	3.937 (100)	20	9 × .5906 (15)
NBT-2185	4.724 (120)	7.283 (185)	396 (180)	16	6.890 (175)	—	5.709 (145)	—	4.528 (115)	22	10 × .5906 (15)
NBT-3055	1.181 (30)	2.165 (55)	277 (126)	4	1.378 (35)	—	—	—	—	2	—
NBT-3080	1.772 (45)	3.150 (80)	405 (184)	4	2.362 (60)	—	—	—	—	4	1 × .9843 (25)
NBT-3105	2.362 (60)	4.134 (105)	484 (220)	4	3.345 (85)	—	—	—	—	6	2 × .9843 (25)
NBT-3130	2.953 (75)	5.118 (130)	605 (275)	4	4.331 (110)	—	—	—	—	8	3 × .9843 (25)
NBT-3155	3.543 (90)	6.102 (155)	682 (310)	6	5.315 (135)	3.346 (85)	—	—	—	10	4 × .9843 (25)
NBT-3180	4.134 (105)	7.087 (180)	781 (355)	6	6.266 (160)	4.331 (110)	—	—	—	12	5 × .9843 (25)
NBT-3205	5.118 (130)	8.071 (205)	825 (375)	10	7.283 (185)	5.315 (135)	3.346 (85)	—	—	14	6 × .9843 (25)
NBT-3230	6.102 (155)	9.055 (230)	924 (420)	10	8.268 (210)	6.299 (160)	4.331 (110)	—	—	16	7 × .9843 (25)
NBT-3255	7.087 (180)	10.04 (255)	990 (450)	10	9.252 (235)	7.283 (185)	5.315 (135)	—	—	18	8 × .9843 (25)
NBT-3280	8.071 (205)	11.02 (280)	1078 (490)	12	10.24 (260)	8.268 (210)	6.299 (160)	4.331 (110)	—	20	9 × .9843 (25)
NBT-3305	9.055 (230)	12.01 (305)	1144 (520)	12	11.22 (285)	9.252 (235)	7.283 (185)	5.315 (135)	—	22	10 × .9843 (25)
NBT-4085	1.969 (50)	3.346 (85)	616 (280)	4	2.559 (65)	—	—	—	—	2	—
NBT-4125	2.953 (75)	4.921 (125)	858 (390)	4	4.134 (105)	—	—	—	—	4	1 × 1.575 (40)
NBT-4165	4.134 (105)	6.496 (165)	1034 (470)	4	5.709 (145)	—	—	—	—	6	2 × 1.575 (40)
NBT-4205	5.118 (130)	8.071 (205)	1243 (565)	6	7.283 (185)	4.134 (105)	—	—	—	8	3 × 1.575 (40)
NBT-4245	6.102 (155)	9.646 (245)	1452 (660)	6	8.858 (225)	5.709 (145)	—	—	—	10	4 × 1.575 (40)
NBT-4285	7.283 (185)	11.22 (285)	1639 (745)	10	10.43 (265)	7.283 (185)	4.134 (105)	—	—	12	5 × 1.575 (40)
NBT-4325	8.268 (210)	12.80 (325)	1826 (830)	10	12.01 (305)	10.04 (225)	5.709 (145)	—	—	14	6 × 1.575 (40)
NBT-6110	2.362 (60)	4.331 (110)	880 (400)	4	3.543 (90)	—	—	—	—	2	—
NBT-6160	3.740 (95)	6.300 (160)	1518 (690)	4	5.512 (140)	—	—	—	—	4	1 × 1.969 (50)
NBT-6210	5.118 (130)	8.268 (210)	1914 (870)	6	7.480 (190)	3.543 (90)	—	—	—	6	2 × 1.969 (50)
NBT-6260	6.496 (165)	10.24 (260)	2288 (1040)	6	9.449 (240)	5.512 (140)	—	—	—	8	3 × 1.969 (50)
NBT-6310	7.874 (200)	12.20 (310)	2640 (1200)	6	11.42 (290)	7.480 (190)	—	—	—	10	4 × 1.969 (50)

Crossed Roller Slide Tables (steel)

Dim. in inches (μm)			
ACCURACY			
PART #	VERTICAL	HORIZONTAL	
NBT-1025	0.00008 (2)	0.00016	(4)
NBT-1035	0.00008 (2)	0.00016	(4)
NBT-1045	0.00008 (2)	0.00016	(4)
NBT-1055	0.00008 (2)	0.00020	(5)
NBT-1065	0.00008 (2)	0.00020	(5)
NBT-1075	0.00008 (2)	0.00020	(5)
NBT-1085	0.00008 (2)	0.00020	(5)
<hr/>			
NBT-2035	0.00008 (2)	0.00016	(4)
NBT-2050	0.00008 (2)	0.00016	(4)
NBT-2065	0.00008 (2)	0.00020	(5)
NBT-2080	0.00008 (2)	0.00020	(5)
NBT-2095	0.00008 (2)	0.00020	(5)
NBT-2110	0.00012 (3)	0.00024	(6)
NBT-2125	0.00012 (3)	0.00024	(6)
NBT-2140	0.00012 (3)	0.00024	(6)
NBT-2155	0.00012 (3)	0.00024	(6)
NBT-2170	0.00012 (3)	0.00028	(7)
NBT-2185	0.00012 (3)	0.00028	(7)
<hr/>			
NBT-3055	0.00008 (2)	0.00008	(5)
NBT-3080	0.00008 (2)	0.00008	(5)
NBT-3105	0.00012 (3)	0.00020	(6)
NBT-3130	0.00012 (3)	0.00020	(6)
NBT-3155	0.00012 (3)	0.00024	(6)
NBT-3180	0.00012 (3)	0.00024	(7)
NBT-3205	0.00012 (3)	0.00028	(7)
NBT-3230	0.00012 (3)	0.00028	(7)
NBT-3255	0.00012 (3)	0.00028	(7)
NBT-3280	0.00012 (3)	0.00028	(7)
NBT-3305	0.00012 (3)	0.00028	(7)
<hr/>			
NBT-4085	0.00008 (2)	0.00020	(5)
NBT-4125	0.00012 (3)	0.00024	(6)
NBT-4165	0.00012 (3)	0.00028	(7)
NBT-4205	0.00012 (3)	0.00028	(7)
NBT-4245	0.00012 (3)	0.00028	(7)
NBT-4285	0.00012 (3)	0.00028	(7)
NBT-4325	0.00016 (4)	0.00031	(8)
<hr/>			
NBT-6110	0.00012 (3)	0.00024	(6)
NBT-6160	0.00012 (3)	0.00024	(6)
NBT-6210	0.00012 (3)	0.00028	(7)
NBT-6260	0.00012 (3)	0.00028	(7)
NBT-6310	0.00012 (3)	0.00028	(7)

Accuracy

Top and bottom mounting surfaces and carriage side surfaces are ground flat and parallel to the line of motion. Accuracy of movement (V) is measured as a deflection over the center line of the carriage as shown. Accuracies, measured without load, depend primarily on overall length as listed. Deflections (H) measured at either side of the carriage under the same conditions.

Ordering

Order standard positioning tables from table by model number according to load and travel required.

Delivery stock to 6 weeks.

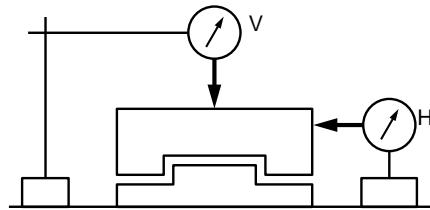

Crossed Roller Slide Tables (Steel)

Load Ratings

See "Ratings and Specifications" page 93

The load capacities stated in the tables may be applied in any direction, and are assumed to be centered and evenly distributed over the table. Calculate moments and cantilevered loads carefully since inadvertent overloading will reduce service life.

SERIES	MOUNTING DIMENSIONS						BASE		
	CARRIAGE		THREAD	DEPTH	SPACING		C'BORE	DEPTH	
	N	P			R	S			
NBT-1000	0.492 (12.5)	0.394 (10)	M2	.236 (6)	0.138 (3.5)	0.866 (22)	0.161 (4.5)	0.100 (2.55)	.100 (2.5)
NBT-2000	0.689 (17.5)	0.591 (15)	M3	.276 (7)	0.197 (5)	1.181 (30)	0.236 (6.5)	0.138 (3.5)	.138 (3.5)
NBT-3000	1.083 (27.5)	0.984 (25)	M4	.374 (9.5)	0.394 (10)	1.575 (40)	0.295 (8)	0.177 (4.5)	.177 (4.5)
NBT-4000	1.673 (42.5)	1.575 (40)	M5	0.512 (13)	0.394 (10)	2.165 (55)	0.374 (10)	0.217 (5.5)	.213 (5.4)
NBT-6000	2.165 (55)	1.969 (50)	M6	.551 (14)	0.394 (10)	2.362 (60)	0.433 (11.5)	0.276 (7)	.276 (7.0)

Dimensions in inches (mm)

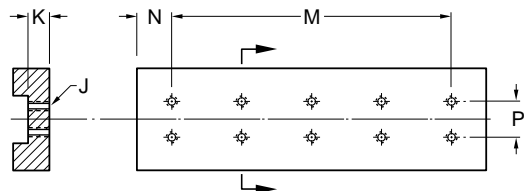

CARRIAGE MOUNTING DIMENSIONS

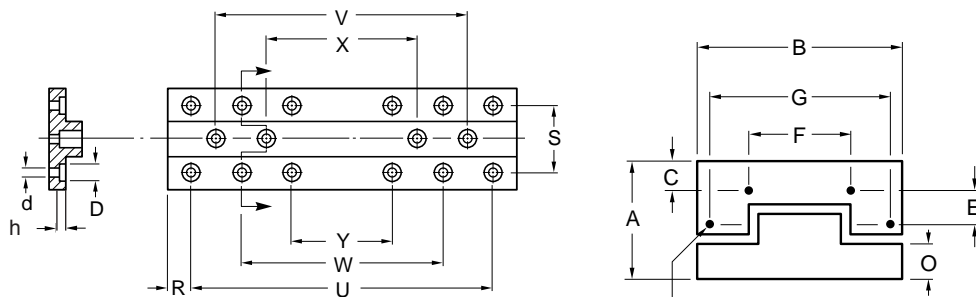

BASE MOUNTING DIRECTIONS

SERIES *	PROFILE DIMENSIONS							
	HEIGHT A	WIDTH B**	FLANGE HEIGHT O	DUST COVER ATTACHMENT HOLES				THREAD
				C	E	F	G	
NBT-1000	0.669 (17)	1.181 (30)	0.217 (5.5)	0.098 (2.5)	—	0.472 (12)	—	M2
NBT-2000	0.827 (21)	1.575 (40)	0.256 (6.5)	0.134 (3.4)	—	0.630 (16)	—	M2
NBT-3000	1.102 (28)	2.362 (60)	0.354 (9)	0.217 (5.5)	—	1.575 (40)	—	M3
NBT-4000	1.378 (35)	3.150 (80)	0.413 (10.5)	0.256 (6.5)	—	2.165 (55)	—	M3
NBT-6000	1.772 (45)	3.937 (100)	0.512 (13)	0.315 (8)	0.591 (15)	2.362 (60)	3.622 (92)	M4

Dimensions in inches (mm)

* Series NBT-1000 Tables use series NB-1 bearings etc.

** Except Series NBT-1000 and NBT-2000 +.008 (+0.2)
-.016 (-0.4)

Recirculating Ball Slide Guides (BSGS)

6 Reasons to choose Del-Tron Recirculating Ball Slide Guides

(BSGS)

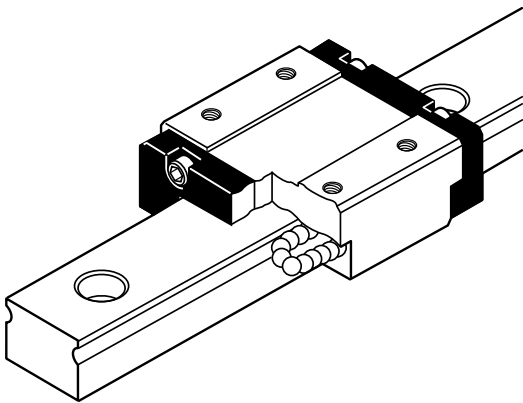

1. Smooth and stable operation.
2. Compact, lightweight and low price.
3. High load capacity due to R-shaped groove.
4. Four-point contact to carry load and moment in all directions.
5. 400 Series Stainless.
6. Extra wide type available.

Recirculating Ball Slide Guides (BSGS)

The BSGS type consists of a block and a guide rail, both having two R-shape raceway grooves machined by precision grinding. The block consists of a main body having raceway grooves and a resin return cap ensuring smooth circulation of balls. These precision steel balls roll in the respective raceway groove with contact at four points.

- Smooth and Stable operation. Since precision steel balls are used as rolling elements, the rolling resistance is extremely small, ensuring smooth and stable operation.
- Compact, lightweight, and low price. The block is a simple structure, so the slide guide is compact and inexpensive. Its compactness and light weight also make this product optimum for linear operation at high speed.
- High load capacity utilizing the R-shaped groove. The raceway surface over which the balls roll is an R-shaped groove, offering a large contact area. Therefore, the product features a large load capacity and a long effective life.
- Four-point contact to carry load and moment in all directions. The Gothic arch groove, where the balls contact the raceway surface at four points, enables the load and moment to be carried in all directions.
- 400 series Stainless steel type (BSGS). The BSGS type uses stainless steel for the block, ball bearing and guide rail, thus having superior corrosion resistance.
- Extra wide type (BSGSW) is also available. With its increased number of rolling elements and increased width, this unit can replace the use of two linear guides. Stiffness in regard to moment load is increased, thus creating an effective compact linear motion mechanism.
- Slide guides are supplied with temporary ends stops. They are not to be used as positive stops.

Nomenclature

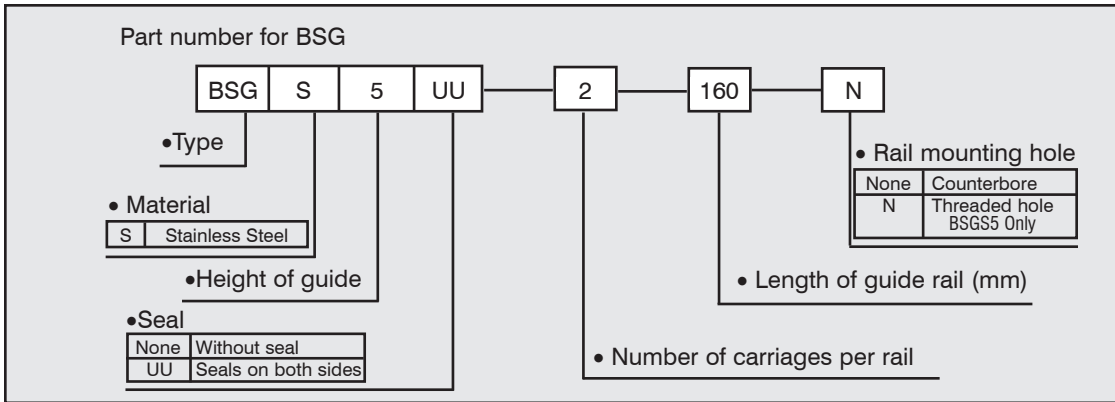

Unit: inches (mm)

Accuracy

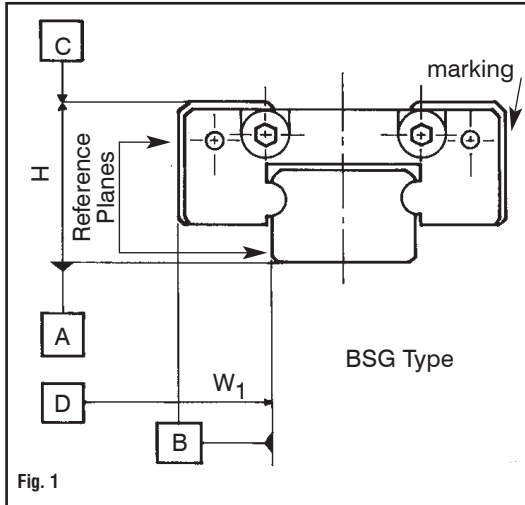

Height (H) tolerance	±.0016	(±0.040)
Difference of heights (H) between paired ones	.0006	(0.015)
Width (W ₁) tolerance	±.0016	(±0.040)
Difference of widths (W ₁) between paired ones	.0008	(0.020)
Running parallelism of C plane with respect to A plane	See Fig. 2	
Running parallelism of D plane with respect to B plane	See Fig. 2	

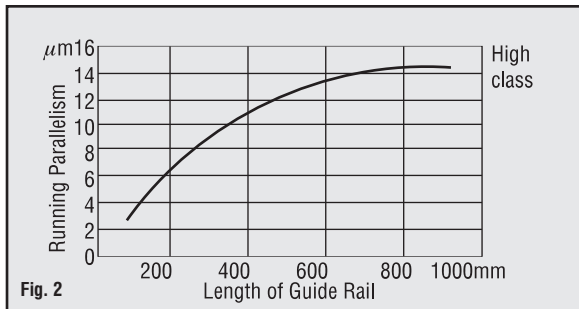

Travel Accuracy

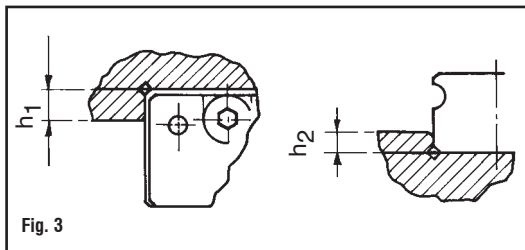

part number	h1	h2
BSGS5	.079 (2)	.039 (1)
BSGS8	.098 (2.5)	.039 (1)
BSGS 10	.118 (3)	.059 (1.5)
BSGS13	.157 (4)	.079 (2)
BGGS16	.197 (5)	.138 (3.5)
BSGS25	.197 (5)	.197 (5)
BSGS9W	.118 (3)	.059 (1.5)
BSGS12W	.118 (3)	.098 (2.5)
BGGS14W	.157 (4)	.098 (2.5)
BSGS16W	.197 (5)	.098 (2.5)

Mounting Requirements

The corners of the reference planes should be finished with undercuts as shown in Figure 3. The recommended heights of the shoulders of the mounting planes are as shown in the table. To attain high accuracy, it is recommended to finish the mounting planes of the bed and table to an accuracy the same as or better than that of the guide rail and block.

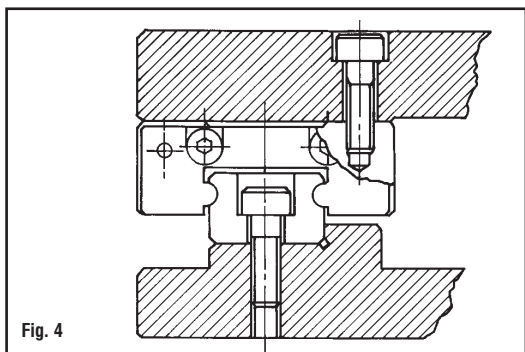

Recommended Tightening Torques: The recommended tightening torques for the mounting bolts (hex socket head bolts) are shown here.

Unit: lb-ft (N·M)

Nominal Bolt Size	Tightening Torques
M2	.295 (4)
M3	.738 (1.0)
M4	1.884 (2.5)
M5	3.614(4.9)

Fixing Method

To install a BSGS Slide Guide (Fig. 4), confirm the reference planes as shown in Figure 1, then let the reference planes of the bed and table make close contact with the reference planes of the object and fix them. When using two guide rails, fix the reference side in a state in which it is closely contacted with the reference plane. Fix the adjustment side after adjusting the traveling state with either the guide rails or the block in a free state.

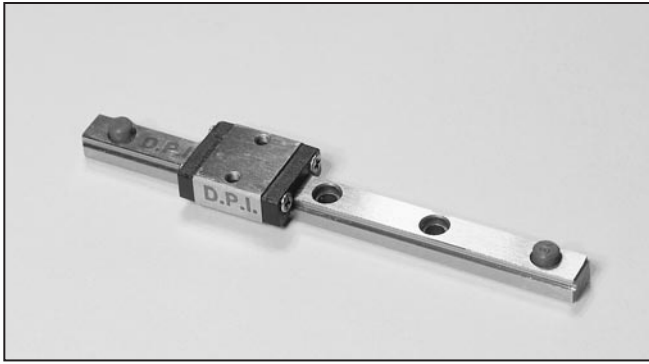

Ball Slide Guide

BSGS (400 series Stainless Steel)

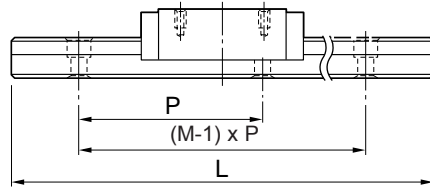

Maximum length is available for special order.

Slide guides are supplied with temporary ends stops. They are not to be used as positive stops.

MODEL	Dims- in (mm)			GUIDE RAIL LENGTHS / [NUMBER OF HOLES]				MAX LENGTH				
	L (Lmm)	[M]		L (Lmm)	[M]	L (Lmm)	[M]	P	STEEL	STAINLESS		
BSGS5 BSGS5UU	1.575 (40)	[3]		2.165 (55)	[4]	2.756 (70)	[5]	3.937 (100)	[7]	.591 (15)	N/A	13.4 (340)
BSGS8 BSGS8UU	1.575 (40)	[3]		2.165 (55)	[4]	2.756 (70)	[5]	3.346 (85)	[6]	.591 (15)	N/A	27.6 (700)
BSGS10 BSGS10UU	2.165 (55)	[3]		2.953 (75)	[4]	3.740 (95)	[5]	4.527 (115)	[6]	.788 (20)	19.7 (500)	39.37 (1000)
BSGS13 BSGS13UU	4.724 (120)	[5]		6.693 (170)	[7]	8.661 (220)	[9]	10.630 (270)	[11]	.984 (25)	19.7 (500)	39.37 (1000)
BSGS16 BSGS16UU	5.906 (150)	[4]		9.055 (230)	[6]	12.205 (310)	[8]	16.929 (430)	[11]	1.575 (40)	74.8 (1900)	39.37 (1000)
BSGS25 BSGS25UU	8.661 (220)	[4]		11.024 (280)	[5]	13.386 (340)	[6]	18.110 (460)	[8]	2.362 (60)	74.8 (1900)	39.37 (1000)

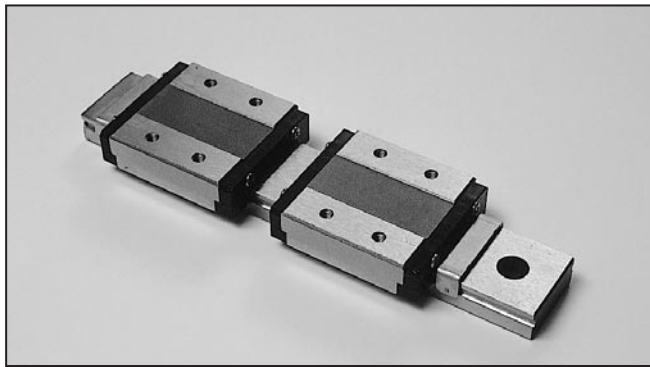

Ball Slide Guide Extra Wide

BSGS-W (400 series Stainless Steel)

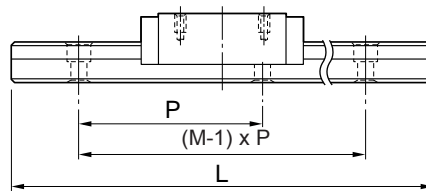

Maximum length is available for special order.

Slide guides are supplied with temporary ends stops. They are not to be used as positive stops.

MODEL	Dims- in (mm)			GUIDE RAIL LENGTHS / [NUMBER OF HOLES]				MAX LENGTH				
	L (Lmm)	[M]		L (Lmm)	[M]	L (Lmm)	[M]	P	STEEL	STAINLESS		
BSGS9W BSGS9WUU	3.150 (80)	[3]		4.331 (110)	[4]	5.512 (140)	[5]	6.693 (170)	[6]	1.181 (30)	N/A	27.6 (700)
BSGS12W BSGS12WUU	3.150 (80)	[3]		4.331 (110)	[4]	5.512 (140)	[5]	6.693 (170)	[6]	1.181 (30)	39.37 (1000)	39.37 (1000)
BSGS14W BSGS14WUU	4.331 (110)	[3]		5.906 (150)	[4]	7.480 (190)	[5]	9.055 (230)	[6]	1.575 (40)	74.8 (1900)	39.37 (1000)
BSGS16W BSGS16WUU	5.906 (150)	[4]		9.055 (230)	[6]	12.205 (310)	[8]	16.929 (430)	[11]	1.575 (40)	74.8 (1900)	39.37 (1000)

Ball Slide Guide

BSGS (Stainless Steel)

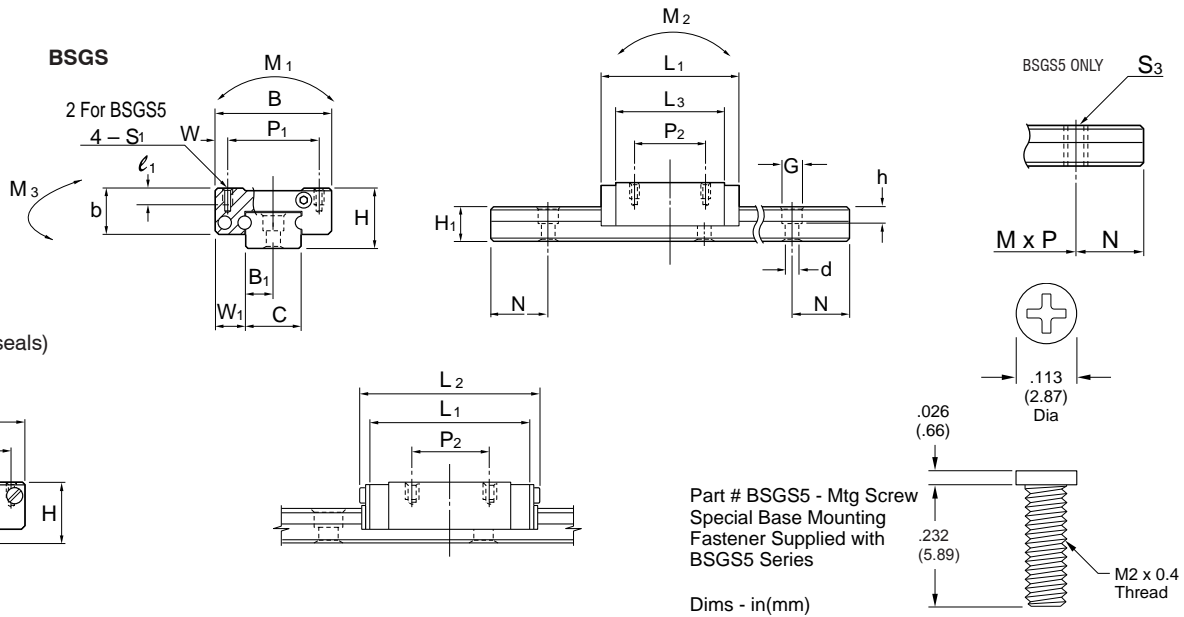

BSGS-UU (with double seals)

2 FOR BSGS5

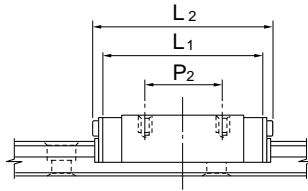
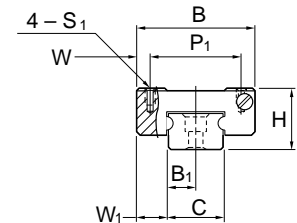

Part # BSGS5 - Mtg Screw
Special Base Mounting
Fastener Supplied with
BSGS5 Series

Dims - in(mm)

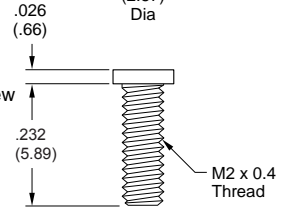

MODEL	Dim- in (mm)											BASIC LOAD RATING	
	DIMENSIONS OF CARRIAGE											Dynamic / Static	
STAINLESS STEEL	H	B	L ₂	L ₁	W	P ₁	P ₂	S ₁	ℓ ₁	L ₃	b	C lbf (kgf)	Co lbf (kgf)
BSGS5 BSGS5UU	.236 (6)	.472 (12)	.669 (17)	.614 (15.6)	.079 (2)	.315 (8)	—	M2	.059 (1.5)	.386 (9.8)	.177 (4.5)	96 (44)	160 (73)
BSGS8 BSGS8UU	.315 (8)	.669 (17)	.925 (23.5)	.862 (21.9)	.098 (2.5)	.473 (12)	.315 (8)	M2	.098 (2.5)	.594 (15.1)	.256 (6.5)	242 (110)	375 (170)
BSGS10 BSGS10UU	.394 (10)	.788 (20)	1.200 (30.5)	1.106 (28.1)	.098 (2.5)	.591 (15)	.394 (10)	M3	.118 (3)	.803 (20.4)	.307 (7.8)	375 (170)	551 (250)
BSGS13 BSGS13UU	.512 (13)	1.063 (27)	1.338 (34)	1.181 (30)	.138 (3.5)	.788 (20)	.591 (15)	M3	.138 (3.5)	.906 (23)	.394 (10)	485 (220)	705 (320)
BSGS16 BSGS16UU	.630 (16)	1.260 (32)	1.673 (42.5)	1.516 (38.5)	.138 (3.5)	.984 (25)	.788 (20)	M3	.157 (4)	1.161 (29.5)	.473 (12)	815 (370)	1212 (550)
BSGS25 BSGS25UU	.984 (25)	1.811 (46)	2.441 (62)	2.193 (55.7)	.157 (4)	1.496 (38)	1.496 (38)	M4	.236 (6)	1.799 (45.7)	.689 (17.5)	1544 (700)	2205 (1000)

MODEL	Dim- in (mm)							WEIGHT	
	DIMENSIONS OF GUIDE RAIL								
STAINLESS STEEL	H ₁	C	B ₁	W ₁	d x G x h	S ₃ N Type	N	Carriage lb (kg)	Guide Rail lb/ft (kg/m)
BSGS5 BSGS5UU	.157 (4)	.197 (5)	.098 (2.5)	.138 (3.5)	.094 x .138 x .039 (2.4x 3.5 x 1)	M2.6	.197 (5)	.007 (.003)	.086 (.13)
BSGS8 BSGS8UU	.185 (4.7)	.276 (7)	.138 (3.5)	.197 (5)	.094 x .165 x .091 (2.4 x 4.2 x 2.3)	—	.197 (5)	.022 (0.01)	.128 (0.19)
BSGS10 BSGS10UU	.217 (5.5)	.354 (9)	.177 (4.5)	.217 (5.5)	.138 x .236 x .138 (3.5 x 6 x 3.5)	—	.295 (7.5)	.044 (0.02)	.208 (0.31)
BSGS13 BSGS13UU	.285 (7.5)	.472 (12)	.236 (6)	.295 (7.5)	.138 x .236 x .177 (3.5 x 6 x 4.5)	—	.394 (10)	.088 (0.04)	.410 (0.61)
BSGS16 BSGS16UU	.374 (9.5)	.591 (15)	.295 (7.5)	.335 (8.5)	.138 x .236 x .177 (3.5 x 6 x 4.5)	—	.591 (15)	.132 (0.06)	.685 (1.02)
BSGS25 BSGS25UU	.591 (15)	.788 (20)	.394 (10)	.512 (13)	.236 x .374 x .335 (6 x 9.5 x 8.5)	—	.788 (20)	.507 (0.23)	1.438 (2.14)

NOTE: Models BSGS5, BSGS8, BSGS5UU and BSGS8UU are available in 400 series Stainless Steel only. moment load ratings + load / life formulas. pg. 100

Ball Slide Guide Extra Wide BSGS-W (Stainless Steel)

BSGS12W ~ 16W

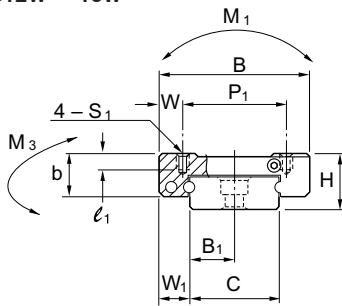

BSGS9W

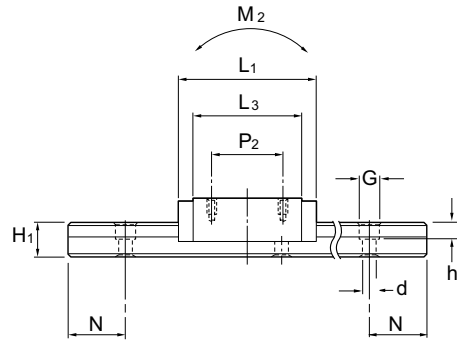
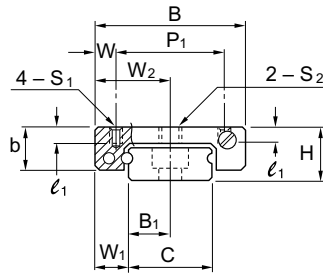

For BSGS16W Guide Rails

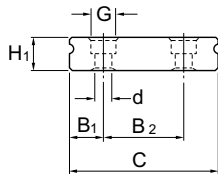

BSGS-WUU
(with double seals)

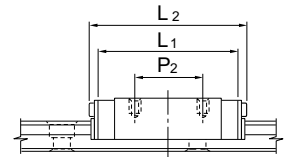
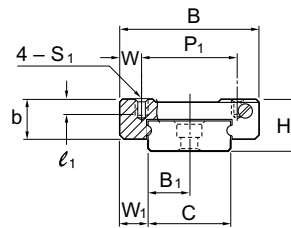

MODEL	Dim- in (mm)														BASIC LOAD RATING	
	DIMENSIONS OF CARRIAGE														Dynamic / Static	
STAINLESS STEEL	H	B	L ₂	L ₁	W	P ₁	P ₂	S ₁	ℓ ₁	L ₃	W ₂	S ₂	ℓ ₂	b	C lbf (kgf)	Co lbf (kgf)
BSGS9W BSGS9WUU	.354 (9)	.984 (25)	1.240 (31.5)	1.185 (30.1)	.138 (3.5)	.748 (19)	.394 (10)	M3	.110 (2.8)	.870 (22.1)	.492 (12.5)	M4	.138 (3.5)	.276 (7)	352 (160)	551 (250)
BSGS12W BSGS12WUU	.472 (12)	1.181 (30)	1.535 (39)	1.390 (35.3)	.177 (4.5)	.827 (21)	.472 (12)	M3	.110 (2.8)	1.118 (28.4)	—	—	—	.354 (9)	507 (230)	750 (340)
BSGS14W BSGS14WUU	.551 (14)	1.575 (40)	1.752 (44.5)	1.602 (40.7)	.236 (6)	1.102 (28)	.591 (15)	M3	.138 (3.5)	1.319 (33.5)	—	—	—	.433 (11)	661 (300)	970 (440)
BSGS16W BSGS16WUU	.630 (16)	2.362 (60)	2.185 (55.5)	2.016 (51.2)	.295 (7.5)	1.772 (45)	.788 (20)	M4	.177 (4.5)	1.654 (42)	—	—	—	.512 (13)	1102 (500)	1587 (720)

MODEL	Dim- in (mm)							WEIGHT	
	DIMENSIONS OF GUIDE RAIL							Carriage	
STAINLESS STEEL	H ₁	C	B ₁	B ₂	W ₁	d x G x h	N	lb (kg)	lb/ft (kg/m)
BSGS9W BSGS9WUU	.205 (5.2)	.551 (14)	.276 (7)	—	.217 (5.5)	.138 x .236 x .126 (3.5 x 6 x 3.2)	.394 (10)	.044 (0.02)	.336 (0.5)
BSGS12W BSGS12WUU	.295 (7.5)	.709 (18)	.354 (9)	—	.236 (6)	.138 x .236 x .177 (3.5 x 6 x 4.5)	.394 (10)	.088 (0.04)	.645 (0.96)
BSGS14W BSGS14WUU	.315 (8)	.945 (24)	.472 (12)	—	.315 (8)	.177 x .315 x .177 (4.5 x 8 x 4.5)	.591 (15)	.176 (0.08)	.941 (1.4)
BSGS16W BSGS16WUU	.374 (9.5)	1.654 (42)	.374 (9.5)	.906 (23)	.354 (9)	.177 x .315 x .177 (4.5 x 8 x 4.5)	.591 (15)	.331 (0.15)	1.982 (2.95)

NOTE: Models BSGS9W and BSGS9WUU are available in Stainless Steel only. moment load ratings + load / life formulas. pg. 100

TECHNICAL SECTION

General Informationpage 89
Life Formulaspage 91
Moment Load Formulas & Ratingspage 93

General Information

1. Ball Slides or Roller Slides

A. *Ball slide design offers the following advantages:*

- Self cleaning (point contact of balls and shafts does not allow foreign material to interfere).
- Low cost (Ball and shaft materials are common and easily manufactured).

B. *Crossed roller slide design offers the following advantages:*

- Line contact of roller to shafts offer 8 x 10 times the load capacity of balls.
- Higher over hanging load capacity and low axial play.

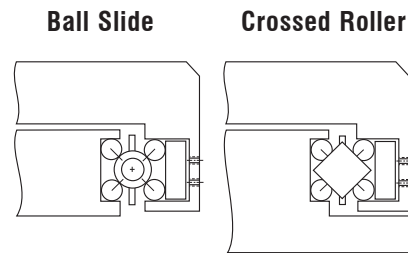

2. Straight Line Design or Recirculating Type

Straight line, or non-recirculating slides, have rolling elements which move on a straight track and are separated by a retainer. The slide reaches the end of its travel when the retainer or rolling element contacts a limiting component, (either a screw head or end cap). This travel limitation is determined by the relationship of the retainer length to the carriage length. Standard slides usually have travel equal to 1/3 the carriage length. Maximum total travel can be as much a 1x the carriage length. Therefore, for more travel, you must specify a longer slide. This design offers extremely low friction and stiction characteristics.

Recirculating slide designs offer travel which is not limited by carriage size. In this design the rolling elements revolve within an oval track inside the carriage. See Del-Tron's BSG series.

Travel ends when ball or roller retainer contacts the end cap.

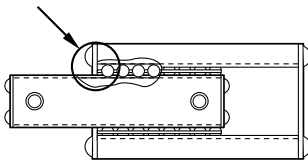

Straight Line Type

Balls recirculate around an oval track. Travel is limited by the length of the base rail.

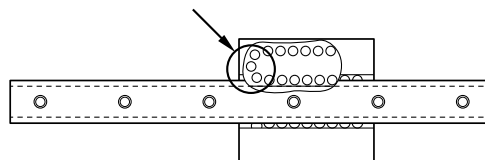

Recirculating Type

3. Standard Tolerances

Dimensions in Inches		Dimensions in Millimeters	
Unless otherwise specified, tolerances are as follows:		Unless otherwise specified, tolerances are as follows:	
Two (2) place decimals	±.010	One (1) place decimals	±0.25
Three (3) place decimals	±.005	Two (2) place decimals	±0.13

4. Custom Slides

Del-Tron's engineering staff will be pleased to assist you in developing custom versions of our linear slides. Our proprietary manufacturing processes allow us to offer completely customized slides built to your requirements even in small quantities in less than eight weeks.

Minor modifications can be provided. Some of the more common modifications we can provide:

- Changes in height, width, or length
- More or less travel
- Increased load capacity
- Light, medium, or heavy preload
- Different holes, threads or hole locations
- Dowel holes and pins
- Reduced or increased axial play
- Multiple carriages on a single base
- Multiple bases on a single carriage
- Non-standard retainer material
- No anodize or non-standard anodize color
- Corrosion resistant stainless steel components

5. High Temperature Applications

Del-Tron® slides can be modified to operate in elevated temperature areas by the substitution of teflon, aluminum, or brass retainers.

6. Static Sensitive Applications

Del-Tron now offers precision linear motion devices that meet low electrostatic discharge requirements common in the semiconductor and electronics industries. The new slides are coated with electroless nickel, an alloy of nickel and phosphorous produced by autocatalytic chemical reduction with hypophosphite. The plating allows static charges to dissipate, helping the slides to meet requirements for automated equipment. Del-Tron's "ESD" electroless nickel plated slides are plated to ASTM standard B 733-97. This process is available for Del-Tron's line of ball slides, crossed roller slides and both ball and crossed roller multi-axis positioning stages.

7. Vacuum Applications

Outgassing of slide components can be reduced or eliminated for vacuum applications by eliminating anodized and oxidized finishes, labels, lubricants, and non-metallic retainers.

8. Preload vs. Axial Play

Many of our slides allow the preload to be set to a specific amount to accommodate the needs of the application. A light, medium, or heavy preload may be ordered. The amount of preload can be expressed as grams of force needed to move either the base or carriage. Please contact our engineering staff to discuss your special preload requirements.

Slide preload and axial play are related.

- Increased preload = less axial play
- Decreased preload = more axial play

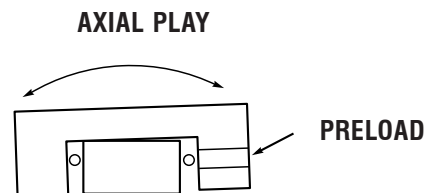

9. Straight Line Accuracy

Straight Line Accuracy = possible runout in any plane

Measured by comparison of the line of travel to a master straight edge, using a gauge or indicator mounted on the slides.

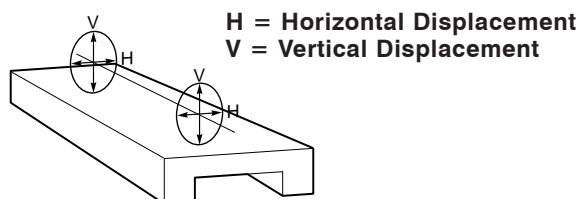

10. Travel

Total Travel is 1/2 distance from center in either direction.

Life Formulas

Linear Ball and Roller Slides

Rated Life

The rated life “L” of a linear slide is the length of travel endured by the slide under a specified condition. Since in reality, life varies from one slide to another, industry normally uses the L10 life rating which is defined as the length of travel that 90% of apparently identical slides will complete before the first evidence of failure.

Speed Factor

The effect of speed on the load rating of a slide can be accounted for by a speed factor:

$$f_s = \sqrt[m]{\frac{30}{V}}$$

where: V = speed of the slide movement in inches/min (when the speed varies during the cycle, the peak value should be used)

m = 3 for ball slides, or
m = 10/3 for roller slides

Note: When the speed is less than 30 in/min, $f_s = 1$.

Temperature Factor

When the temperature of the slide exceeds certain limits, it reduces the hardness of contacting elements and consequently affects the load rating of the slide. Therefore, its load rating shall be adjusted by a temperature factor “ft”. The values of this factor are presented in Table 1.

Table 1

Temperature, deg.F	Temperature Factor, “ft”	
	Regular Bearing Steel Contacting Elements	Stainless Steel Contacting Elements
220	1	1
300	0.9	1
400	0.75	0.9
500	not recommended	0.75

Note: When specifying slides for elevated temperature service, it should be kept in mind that the delrin retainers found in many slides are not recommended for temperatures above 180 deg.F.

Load Type Factor

In reality, the load endured by a slide can never be absolutely smooth, but rather is a sum of variable forces that include working load, inertial forces, vibrations, impacts, occasional loads, etc. In order to have their influence taken into account, the load rating of the slide shall be adjusted by a load type factor “fw”.

The values of “fw” for calculations per formula (2) and (3) are presented in Table 2.

Table 2

Condition of Load	Value of “fw”
Relatively smooth motion	1 to 1.5
Motion with impacts	2 to 3

Life Formula for Ball and Roller Slides

Based on the above definitions and role of different factors, the real life of linear slides can be obtained from the following formula:

Formula 2

$$L_{10} = \left(\frac{C \times f_s \times f_t \times f_w}{P_c} \right)^m \times 10^6 \text{ inches}$$

where:

L10 = life of the slide at 90% of reliability as defined above (in inches).

C = catalog "load capacity" of the slide in lbs. (which is a load that corresponds to an L10 life of 10 million inches, provided the factors fs, ft and fw are equal to 1.

Pc = calculated effective load the slide is subjected to in lbs. (fs, ft and fw are factors as described above.)

m = 3 for ball slides, or 10/3 for roller slides.

When other than 90% reliability is required (for instance, "K"% reliability), the known value of L10 shall be multiplied by a reliability factor "fr" so that:

$$L_n = f_r \times L_{10}$$

where:

Ln = rated life at the reliability of K%
(n = 100-K).

The values of the factor "fr" are presented in Table 3.

Table 3

RELIABILITY K%	"Ln" rated life	"fr", reliability factor
50	L50	5.00
90	L10	1.00
95	L5	0.62
97	L3	0.44
99	L1	0.21

The general formula for the life of Del-Tron linear slides is expressed as followings:

Example

$$L_n = f_r \times \left(\frac{C \times f_s \times f_t \times f_w}{P_c} \right)^m \times 10^6 \text{ inches} \quad \text{Formula 3}$$

Design considerations lead to the selection of a ball slide. The available space accommodates the Del-Tron S2-4 slide. Find the life at 95% reliability (L5 life) under the following conditions:

- Peak speed during the cycle:
V = 150 in/min.
- Working temperature of slide = 150 deg.F.
- Calculated effective load the slide is subjected to: Pc = 20 lbs.
- Type of load: Moderate vibration, no impacts.

Solution:

- (1) With the formula (1) the speed factor "fs" is found as:

$$f_s = \sqrt[3]{\frac{30}{150}} = 0.58$$

- (2) The value of the temperature factor "ft" is found in Table 1 as: ft = 1.
- (3) Using Table 2, the value of the type of load factor can be estimated as: fw = 1.25.
- (4) The value of reliability factor "fr" is found in Table 3 as: fr = 0.62.
- (5) The value of the load capacity for the Del-Tron S2-4 slide is found in the Del-Tron Catalog as: C = 60 lbs.
- (6) The required life of the slide can then be calculated using formula (3):

$$L_5 = 0.62 \times \left(\frac{60 \times 0.58 \times 1}{20 \times 1.25} \right)^3 \times 10^6 = 1.67 \times 10^6 \text{ inches}$$

Moment Load Ratings

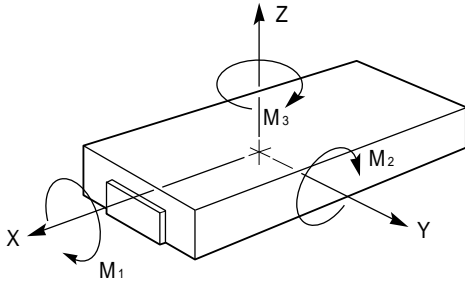

A = Distance (inches) from slide centerline to line of acting force.

F = Acting force (lbs).

L = Published load capacity (lbs).

M1, M2, M3 = Moment load rating (lbs - inch).

m1 - m2 - m3 = Acting moment load (lbs - inch).

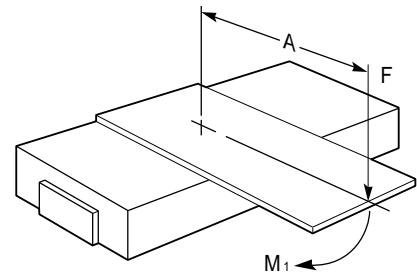

$$m1 = [F \times A]$$

$$\left[\frac{F}{L} + \frac{m1}{M1} \right] \leq 1$$

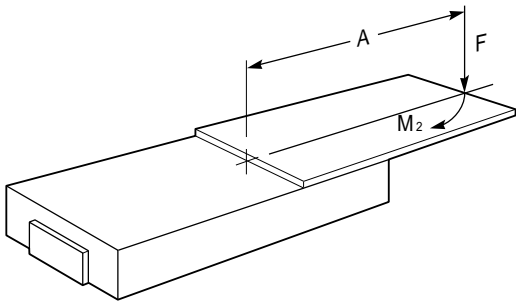

$$m2 = [F \times A]$$

$$\left[\frac{F}{L} + \frac{m2}{M2} \right] \leq 1$$

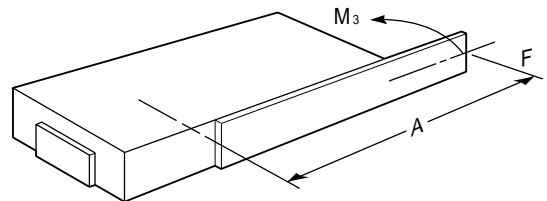

$$m3 = [F \times A]$$

$$\left[\frac{F}{L} + \frac{m3}{M3} \right] \leq 1$$

Moment Load Ratings

Ball Slide Assemblies

Refer to Page 7

Anti-Creep Ball Slide Assemblies

Refer to Page 10

MODEL #	M1 lb-in	M2 lb-in	M3 lb-in	MODEL #	M1 lb-in	M2 lb-in	M3 lb-in
C-.5	.124	.144	.151	C-1AC	.124	.216	.227
C-1	.124	.216	.227	C-2AC	.124	.324	.340
C-2	.124	.324	.340	C-3AC	.124	.486	.510
C-3	.124	.486	.510				
D-1	.51	.96	1.01	D-1AC	.51	.96	1.01
D-2	1.22	4.48	4.70	D-2AC	1.22	4.48	4.70
D-3	1.53	8.64	9.07	D-3AC	1.53	8.64	9.07
D-4	1.79	13.44	14.11	D-4AC	1.79	13.44	14.11
D-5	2.04	17.92	18.81	D-5AC	2.04	17.92	18.81
D-6	2.30	23.04	24.19	D-6AC	2.30	23.04	24.19
E-1	1.55	1.92	2.01	E-1AC	1.55	1.92	2.01
E-2	1.94	4.80	5.04	E-2AC	1.94	4.80	5.04
E-3	2.33	8.64	9.07	E-3AC	2.33	8.64	9.07
E-4	2.72	13.44	14.11	E-4AC	2.72	13.44	14.11
E-5	3.10	17.92	18.81	E-5AC	3.10	17.92	18.81
E-6	3.49	23.04	24.19	E-6AC	3.49	23.04	24.19
M-1	2.50	3.33	3.50	M-1AC	2.50	3.33	3.50
M-2	3.00	8.64	9.07	M-2AC	3.00	8.64	9.07
M-2.5	3.25	10.40	10.92	M-2.5AC	3.25	10.40	10.92
M-3	3.75	13.20	13.86	M-3AC	3.75	13.20	13.86
M-4	4.50	20.16	21.17	M-4AC	4.50	20.16	21.17
N-1	3.85	4.50	4.73	N-1AC	3.85	4.50	4.73
N-2	4.62	10.80	11.34	N-2AC	4.62	10.80	11.34
N-3	5.13	18.00	18.90	N-3AC	5.13	18.00	18.90
N-4	6.41	27.50	28.88	N-4AC	6.41	27.50	28.88
N-6	7.70	45.00	47.25	N-6AC	7.70	45.00	47.25
N-8	8.98	66.50	69.83	N-8AC	8.98	66.50	69.83
N-10	10.26	92.00	96.60	N-10AC	10.26	92.00	96.60
S1-1	5.56	6.00	6.30	S1-1AC	5.56	6.00	6.30
S1-2	7.38	12.00	12.60	S1-2AC	7.38	12.00	12.60
S1-3	9.23	20.00	21.00	S1-3AC	9.23	20.00	21.00
S1-3.5	11.07	33.00	34.65	S1-3.5AC	11.07	33.00	34.65
S1-4	12.92	49.00	51.45	S1-4AC	12.92	49.00	51.45
S1-6	16.61	81.00	85.05	S1-6AC	16.61	81.00	85.05
S1-8	20.30	121.00	127.05	S1-8AC	20.30	121.00	127.05
S2-1	8.51	8.00	8.40	S2-1AC	8.51	8.00	8.40
S2-1.5	12.76	18.00	18.90	S2-1.5AC	12.76	18.00	18.90
S2-2	17.86	29.40	30.87	S2-2AC	17.86	29.40	30.87
S2-3	22.11	41.60	43.68	S2-3AC	22.11	41.60	43.68
S2-4	25.52	84.00	88.20	S2-4AC	25.52	84.00	88.20
S2-6	31.89	135.00	141.75	S2-6AC	31.89	135.00	141.75
S2-8	38.27	198.00	207.90	S2-8AC	38.27	198.00	207.90
S3-1	21.87	16.80	17.64	S3-1AC	21.87	16.80	17.64
S3-1.5	25.52	16.80	17.64	S3-1.5AC	25.52	16.80	17.64
S3-2	45.20	60.76	63.80	S3-2AC	45.20	60.76	63.80
S3-3	64.15	110.88	116.42	S3-3AC	64.15	110.88	116.42
S3-4	86.02	181.72	190.81	S3-4AC	86.02	181.72	190.81
S3-5	98.42	283.50	297.68	S3-5AC	98.42	283.50	297.68
S3-6	109.35	357.00	374.85	S3-6AC	109.35	357.00	374.85
S3-9	134.87	543.90	571.10	S3-9AC	134.87	543.90	571.10
S3-12	149.45	717.50	753.38	S3-12AC	149.45	717.50	753.38

Moment Load Ratings

Crossed Roller Slide Assemblies

Refer to Page 16

MODEL #	M1 lb-in	M2 lb-in	M3 lb-in	MODEL #	M1 lb-in	M2 lb-in	M3 lb-in
RD-1	3.83	7.20	7.56	RS1-1	48.71	59.14	62.10
RD-2	6.30	23.52	24.70	RS1-2	55.71	84.56	88.79
RD-3	8.43	43.56	45.74	RS1-3	64.94	137.98	144.88
RD-4	8.95	67.20	70.55	RS1-3.5	77.49	231.00	242.55
RD-5	10.20	89.60	94.05	RS1-4	113.65	413.95	434.65
RD-6	11.50	115.25	120.95	RS1-6	132.88	648.00	680.40
				RS1-8	152.25	907.50	952.88
RE-1	9.31	11.52	12.10	RS2-1	56.13	59.14	62.10
RE-2	13.58	33.60	35.28	RS2-1.5	63.80	90.00	94.50
RE-3	18.23	62.40	65.14	RS2-2	74.84	118.27	124.19
RE-4	19.04	94.08	98.77	RS2-3	74.84	137.98	144.19
RE-5	20.15	116.48	122.27	RS2-4	130.98	413.95	434.65
RE-6	20.94	138.24	145.14	RS2-6	159.45	675.00	708.50
				RS2-8	191.35	990.00	1039.50
RM-1	17.50	23.31	24.50	RS3-1	164.03	126.00	132.30
RM-2	19.50	56.16	58.96	RS3-1.5	190.67	158.40	166.32
RM-2.5	19.50	62.40	65.52	RS3-2	254.23	316.80	332.64
RM-3	20.63	72.60	76.23	RS3-3	317.80	528.00	554.40
RM-4	22.50	100.80	105.85	RS3-4	317.80	660.00	693.00
				RS3-5	344.47	992.25	1041.88
RN-1	28.11	32.85	31.39	RS3-6	508.46	1478.40	1552.32
RN-2	33.86	73.92	77.62	RS3-9	539.48	2175.60	2284.40
RN-3	50.27	153.66	161.35	RS3-12	567.91	2726.50	2862.84
RN-4	61.56	241.92	254.01				
RN-6	73.15	427.50	448.88				
RN-8	76.33	565.25	593.56				
RN-10	82.08	736.00	772.80				

Precision Series Ball Slides

Refer to Page 19

MODEL #	M1 lb-in	M2 lb-in	M3 lb-in
M-2SS	3.00	8.64	9.07
M-3SS	5.32	17.95	23.62
M-4SS	6.90	28.22	32.68
S2-1SS	8.51	8.00	8.40
S2-1.5SS	12.76	18.00	18.90
S2-2SS	17.86	29.40	30.87
S2-3SS	22.11	41.60	43.68
S2-4SS	25.52	84.00	88.20
S3-1SS	21.87	16.80	17.64
S3-2SS	45.20	60.76	63.80
S3-3SS	64.15	110.88	116.42
S3-4SS	86.02	181.72	190.81
S3-5SS	98.42	283.50	297.68
S3-6SS	109.35	357.00	374.85
S5-3SS	73.77	127.51	133.88
S5-5SS	145.36	539.45	547.36
S5-7SS	157.33	627.98	659.12

Precision Series Crossed Roller Slides

Refer to Page 21

MODEL #	M1 lb-in	M2 lb-in	M3 lb-in
RS2-1SS	39.29	41.40	43.46
RS2-2SS	52.39	82.78	86.93
RS2-3SS	61.12	96.58	100.93
RS2-4SS	67.84	107.20	112.03
RS3-1SS	160.16	133.06	139.71
RS3-2SS	213.55	266.11	279.42
RS3-3SS	266.95	443.52	465.70
RS3-4SS	317.86	554.40	582.12
RS3-5SS	365.53	637.56	669.44
RS5-3SS	170.80	639.15	652.77
RS5-5SS	187.69	702.36	717.33
RS5-7SS	203.57	820.95	862.00

Moment Load Ratings

High Precision Ball Slides

Refer to Page 22

MODEL #	M1 lb-in	M2 lb-in	M3 lb-in
HPM1	2.50	3.33	3.50
HPM-2	3.50	9.12	9.55
HPM-2.5	4.88	15.60	16.38
HPM-3	6.56	23.10	32.92
HPS2-1	8.51	8.00	8.40
HPS2-1.5	12.76	18.00	18.90
HPS2-2	17.86	29.40	30.87
HPS2-3	22.11	41.60	43.68
HPS3-1	40.35	33.25	35.22
HPS3-2	61.23	82.32	86.44
HPS3-3	74.36	128.52	134.94
HPS3-4	96.22	203.28	213.44
HPS3-5	105.71	304.50	319.73
HPS4-2	98.42	283.50	297.68
HPS4-3	109.35	357.00	374.85
HPS4-5	124.35	465.33	475.25
HPS4-6.5	134.87	543.90	571.10
HPS4-9	149.45	717.50	753.38
HPS5-5	143.00	535.13	546.54
HPS5-7	155.10	625.49	656.77
HPS5-10	171.87	825.13	866.39

NOTE: Ratings for FB (Flanged Base) type are the same.

High Precision Crossed Roller Slides

Refer to Page 25

MODEL #	M1 lb-in	M2 lb-in	M3 lb-in
HPRS2-1	44.65	47.04	49.39
HPRS2-1.5	49.68	73.36	75.92
HPRS2-2	59.53	94.07	98.78
HPRS2-3	69.45	109.75	114.69
HPRS3-1	158.26	131.47	138.05
HPRS3-2	180.50	224.93	236.17
HPRS3-3	251.06	417.12	437.98
HPRS3-4	332.99	580.80	609.84
HPRS3-5	382.94	667.92	701.32
HPRS4-2	172.24	496.13	520.94
HPRS4-3	191.36	624.75	655.99
HPRS4-5	217.61	814.33	831.69
HPRS4-6.5	236.02	951.83	999.43
HPRS4-9	261.54	1255.63	1318.42
HPRS5-5	250.25	936.48	956.44
HPRS5-7	271.43	1094.60	1149.34
HPRS5-10	300.77	1443.97	1516.18

NOTE: Ratings for FB (Flanged Base) type are the same.

Posi-Drive Stages

Refer to Page 27

MODEL #	M1 lb-in	M2 lb-in	M3 lb-in	MODEL #	M1 lb-in	M2 lb-in	M3 lb-in
LS1-1	5.56	6.00	6.30	LRS1-1	48.71	59.14	62.10
LS1-2	7.38	12.00	12.60	LRS1-2	55.71	84.56	88.79
LS1-3	9.23	20.00	21.00	LRS1-3	64.94	137.98	144.88
LS1-4	12.92	49.00	51.45	LRS1-4	113.65	413.95	434.65
LS2-1	8.51	8.00	8.40	LRS2-1	56.13	59.14	62.10
LS2-1.5	12.76	18.00	18.90	LRS2-1.5	62.45	92.22	98.44
LS2-2	17.86	29.40	30.87	LRS2-2	74.84	118.27	124.19
LS2-3	22.11	41.60	43.68	LRS2-3	87.31	137.98	144.19
LS2-4	25.52	84.00	88.20	LRS2-4	130.98	413.95	434.65
LS3-1	21.87	16.80	17.64	LRS3-1	190.67	158.40	166.32
LS3-2	45.20	60.76	63.80	LRS3-2	254.23	316.80	332.64
LS3-3	64.15	110.88	116.42	LRS3-3	317.80	528.00	554.40
LS3-4	86.02	181.72	190.81	LRS3-4	378.40	660.00	693.00
LS3-6	109.35	357.00	374.85	LRS3-6	508.46	1478.40	1552.32
LS3-8	122.48	442.00	477.23	LRS3-8	569.51	1830.40	1976.29
LS3-10	141.89	629.66	665.22	LRS3-10	659.76	2607.50	2754.79
LS3-12	149.45	717.50	753.38	LRS3-12	697.24	2871.30	3121.62

Moment Load Ratings

Ball Slide Positioning Stages (Including Side Drive)

Refer to Pages 44-61

MODEL #	M1 lb-in	M2 lb-in	M3 lb-in	MODEL #	M1 lb-in	M2 lb-in	M3 lb-in
99	0.97	0.97	0.97	502	17.86	17.86	17.86
101	1.68	1.60	1.60	701	43.74	43.74	43.74
201	2.52	2.40	2.40	702	43.74	43.74	43.74
301	4.43	4.43	4.43				
				1201	18.14	17.28	17.28
450	8.51	8.51	8.51	1203	18.14	17.28	17.28
451	8.51	8.51	8.51	2201	28.44	26.88	26.88
453	8.51	8.51	8.51	2202	28.44	26.88	26.88
750	43.74	43.74	43.74	2203	28.44	26.88	26.88
751	43.74	43.74	43.74	2204	28.44	26.88	26.88
753	43.74	43.74	43.74	3201	37.63	35.84	35.84
				3202	37.63	35.84	35.84
301P	4.43	6.00	6.30	3203	37.63	35.84	35.84
451P	8.51	10.00	10.50	3204	37.63	35.84	35.84
452P	8.51	10.00	10.50				
751P	43.74	50.88	53.42	1202P	25.6	17.28	18.14
752P	43.74	50.88	53.42	1204P	25.6	17.28	18.14
				2205P	42.47	26.88	28.44
401	8.51	8.51	8.51	2206P	42.47	26.88	28.44
501	17.86	17.86	17.86	3205P	42.47	26.88	28.44
				3206P	62.93	35.84	37.63

Crossed Roller Positioning Stages (Including Side Drive)

Refer to Pages 50-61

MODEL #	M1 lb-in	M2 lb-in	M3 lb-in	MODEL #	M1 lb-in	M2 lb-in	M3 lb-in
R99	5.57	5.57	5.57	R701	116.64	116.64	116.64
R101	9.66	9.20	9.20	R702	116.64	116.64	116.64
R201	14.49	13.80	13.80				
R301	25.47	25.47	25.47	R1201	51.40	48.96	48.96
				R1203	51.40	48.96	48.96
R450	17.02	17.02	17.02	R2201	80.58	76.16	76.16
R451	17.02	17.02	17.02	R2202	80.58	76.16	76.16
R453	17.02	17.02	17.02	R2203	80.58	76.16	76.16
R750	87.48	87.48	87.48	R2204	80.58	76.16	76.16
R751	87.48	87.48	87.48	R3201	106.62	101.55	101.55
R753	87.48	87.48	87.48	R3202	106.62	101.55	101.55
				R3203	106.62	101.55	101.55
R301P	14.77	20.00	21.00	R3204	106.62	101.55	101.55
R451P	17.02	20.00	21.00				
R452P	17.02	20.00	21.00	R1202P	72.53	48.96	51.40
R751P	87.48	101.76	106.85	R1204P	72.53	48.96	51.40
R752P	87.48	101.76	106.85	R2205P	120.33	76.16	80.58
				R2206P	120.33	76.16	80.58
R401	17.02	17.02	17.02	R3205P	120.33	76.16	80.58
R501	34.02	34.02	34.02	R3206P	178.30	101.55	106.62
R502	34.02	34.02	34.02				

Moment Load Ratings

Low Profile Crossed Roller Slide Tables

Refer to Page 62

MODEL #	M1 lb-in	M2 lb-in	M3 lb-in	MODEL #	M1 lb-in	M2 lb-in	M3 lb-in
LPT-1025	7.1	11.4	11.8	LPT-2095	54.6	177.5	186.4
LPT-1035	9.2	22.9	24.0	LPT-2110	62.4	234.1	245.8
LPT-1045	13.4	40.3	42.4	LPT-2125	67.6	287.4	301.8
LPT-1055	15.4	47.4	49.8	LPT-3055	87.4	131.1	137.6
LPT-1065	17.2	72.2	73.7	LPT-3080	127.6	275.2	288.9
LPT-1075	20.1	102.5	107.7	LPT-3105	152.6	429.8	450.6
LPT-1085	22.6	123.3	129.5	LPT-3130	190.7	661.6	694.7
LPT-2035	20.8	27.1	28.4	LPT-3155	215.0	887.0	931.0
LPT-2050	32.8	57.4	60.2	LPT-3180	246.2	1200.0	1260.0
LPT-2065	39.0	87.8	92.2	LPT-3205	260.7	1395.0	1465.0
LPT-2080	49.4	135.9	142.7				

Crossed Roller Rail Sets and Anti-Creep Rail Sets

Refer to Page 65-71

MODEL #	M1 lb-in	M2 lb-in	M3 lb-in	MODEL #	M1 lb-in	M2 lb-in	M3 lb-in
NB1-020	0	9.7	10.2	NB3-200	0	1382.3	1451.4
NB1-030	0	19.2	20.1	NB3-225	0	1691.5	1776.1
NB1-040	0	36.7	38.6	NB3-250	0	2152.5	2260.1
NB1-050	0	61.1	64.1	NB3-275	0	2534.4	2661.1
NB1-060	0	91.5	96.0	NB3-300	0	3092.1	3246.7
NB1-070	0	128.9	135.3	NB3-325	0	3546.8	3724.1
NB1-080	0	159.4	167.3	NB3-350	0	4201.8	4411.9
NB2-030	0	21.8	22.9	NB4-080	0	247.4	259.8
NB2-045	0	54.6	57.3	NB4-120	0	602.3	632.4
NB2-060	0	102.7	107.9	NB4-160	0	1117.2	1173.1
NB2-075	0	142.8	149.9	NB4-200	0	1777.3	1866.2
NB2-090	0	216.0	226.8	NB4-240	0	2629.8	2761.3
NB2-105	0	272.5	286.1	NB4-280	0	3601.5	3781.6
NB2-120	0	370.8	389.4	NB4-320	0	4725.4	4961.7
NB2-135	0	443.8	466.0	NB4-360	0	6002.3	6302.4
NB2-150	0	567.2	595.5	NB4-400	0	7431.3	7802.9
NB2-165	0	706.9	742.2	NB4-440	0	9087.7	9542.0
NB2-180	0	864.0	907.2	NB4-480	0	10828.9	11370.3
NB3-050	0	87.3	91.7	NB6-100	0	803.8	844.0
NB3-075	0	176.7	185.5	NB6-150	0	1788.0	1877.4
NB3-100	0	344.4	361.6	NB6-200	0	3104.4	3259.6
NB3-125	0	506.5	531.8	NB6-250	0	4850.6	5093.1
NB3-150	0	771.4	809.9	NB6-300	0	6901.6	7246.7
NB3-175	0	1018.6	1069.5	NB6-350	0	9410.0	9880.5
				NB6-400	0	12305.9	12921.2

Moment Load Ratings

Crossed Roller Slide Tables (Aluminum)

Refer to Page 72-77

MODEL #	STAINLESS STEEL	M1 lb-in	M2 lb-in	M3 lb-in	MODEL #	STAINLESS STEEL	M1 lb-in	M2 lb-in	M3 lb-in
NBT-1050A	SS	22.2	56.4	59.2	NBT-3105A	SS	167.6	423.7	444.9
NBT-1065A	SS	26.4	82.5	86.6	NBT-3105A-60	SS	167.6	423.7	444.9
NBT-1080A	SS	33.6	124.7	130.9	NBT-3130A-75	SS	184.4	466.1	489.4
NBT-1095A	SS	37.5	161.4	169.4	NBT-3155A	SS	218.6	878.1	922.0
NBT-1125A	SS	45.8	270.9	284.5	NBT-3155A-90	SS	218.6	878.1	922.0
NBT-2035A-18	SS	23.0	42.3	44.4	NBT-3180A	SS	270.3	1109.0	1164.4
NBT-2050A	SS	30.7	56.4	59.2	NBT-3180A-105	SS	270.3	1109.0	1164.4
NBT-2050A-30	SS	30.7	56.4	59.2	NBT-3205A	SS	285.7	1283.6	1347.7
NBT-2065A	SS	36.4	82.5	86.6	NBT-3205A-130	SS	285.7	1283.6	1347.7
NBT-2065A-40	SS	36.4	82.5	86.6	NBT-3230A-155	SS	314.3	1412.0	1482.5
NBT-2080A-50	SS	46.3	124.7	130.9	NBT-3255A-180	SS	336.3	1510.8	1586.2
NBT-2080A	SS	46.3	124.7	130.9	NBT-3280A-205	SS	366.5	1646.8	1729.0
NBT-2095A-60	SS	45.8	270.9	284.5	NBT-3305A-230	SS	388.5	1745.6	1832.7
NBT-2095A	SS	45.8	270.9	284.5	NBT-4085A	SS	304.8	403.5	423.7
NBT-2110A-70	SS	58.8	215.6	226.8	NBT-4125A	SS	425.3	821.0	862.1
NBT-2125A	SS	63.2	270.9	284.5	NBT-4165A	SS	512.5	1423.2	1494.3
NBT-2125A-80	SS	63.2	270.9	284.5	NBT-4205A	SS	616.6	1938.7	2035.6
NBT-2155A-100	SS	94.8	406.4	426.8	NBT-4245A	SS	720.1	2700.9	2836.0
NBT-2185A-120	SS	113.8	487.6	512.1	NBT-6110A	SS	491.5	697.6	732.4
NBT-3055A	SS	95.7	128.5	135.0	NBT-6160A	SS	847.3	1826.6	1918.0
NBT-3055A-30	SS	95.7	128.5	135.0	NBT-6260A	SS	1276.6	4633.6	4865.3
NBT-3080A-45	SS	114.8	154.2	162.0	NBT-6360A	SS	1621.3	7859.8	8252.8

Crossed Roller Slides (Aluminum) Inch Series

Refer to Page 72

MODEL #	M1 lb-in	M2 lb-in	M3 lb-in	MODEL #	M1 lb-in	M2 lb-in	M3 lb-in
NBTA-221	76.6	102.8	108.0	NBTA-443	417.8	593.0	622.5
NBTA-232	103.4	138.8	145.8	NBTA-465	635.5	1370.0	1438.5
NBTA-243	130.7	330.5	347.0	NBTA-487	826.1	1780.9	1870.1
NBTA-254	165.9	419.5	440.5	NBTA-4109	1059.6	3845.9	4038.2
NBTA-265	170.5	684.9	719.2	NBTA-41211	1271.5	4615.1	4845.8
NBTA-276	210.8	865.0	908.2	NBTA-41413	1459.2	7073.8	7427.5
NBTA-287	228.6	1026.9	1078.2	NBTA-41615	1605.1	7781.2	8170.3
NBTA-298	260.6	1171.9	1230.5				
NBTA-2109	279.1	1254.0	1316.6				
NBTA-21110	304.2	1366.8	1435.1				
NBTA-21211	322.5	1448.8	1521.2				
NBTA-332	103.4	138.8	145.8				
NBTA-343	130.7	330.5	347.0				
NBTA-354	165.9	419.5	440.5				
NBTA-365	170.5	684.9	719.2				
NBTA-376	210.8	865.0	908.2				
NBTA-387	228.6	1026.9	1078.2				
NBTA-398	260.8	1171.9	1230.5				
NBTA-3109	279.1	1254.0	1316.6				
NBTA-31110	304.2	1366.8	1435.1				
NBTA-31211	322.5	1448.8	1521.2				

Moment Load Ratings

Crossed Roller Slide Tables (Steel)

Refer to Page 80

MODEL #	M1 lb-in	M2 lb-in	M3 lb-in	MODEL #	M1 lb-in	M2 lb-in	M3 lb-in
NBT-1025	6.0	7.8	8.2	NBT-3105	240.0	571.7	600.3
NBT-1035	8.1	14.3	15.0	NBT-3130	300.0	881.2	925.3
NBT-1045	10.2	22.5	23.7	NBT-3155	338.2	1181.4	1240.4
NBT-1055	13.2	35.0	36.7	NBT-3180	387.3	1568.2	1646.7
NBT-1065	16.2	49.6	52.1	NBT-3205	409.1	1819.0	1910.0
NBT-1075	18.3	65.3	68.6	NBT-3230	458.2	2219.1	2330.0
NBT-1085	20.4	83.1	87.3	NBT-3255	490.9	2572.6	2701.2
				NBT-3280	534.6	3011.7	3162.3
				NBT-3305	567.3	3424.0	3595.2
NBT-2035	28.1	36.0	37.8				
NBT-2050	43.7	75.5	79.3				
NBT-2065	52.6	116.9	122.8	NBT-4085	436.6	581.9	611.0
NBT-2080	66.7	181.0	190.1	NBT-4125	608.1	1182.2	1241.3
NBT-2095	73.7	236.5	248.3	NBT-4165	732.8	1831.8	1923.4
NBT-2110	84.2	311.8	327.4	NBT-4205	881.0	2740.6	2877.6
NBT-2125	91.2	382.8	401.9	NBT-4245	1029.1	3830.4	4021.9
NBT-2140	101.8	477.3	501.1	NBT-4285	1161.6	4968.5	5216.9
NBT-2155	108.8	563.8	592.0	NBT-4325	1294.2	6329.6	6646.1
NBT-2170	119.3	677.3	711.2				
NBT-2185	126.3	779.5	818.5	NBT-6110	702.1	1108.8	1164.2
				NBT-6160	1211.1	2689.9	2824.4
NBT-3055	137.4	174.5	183.2	NBT-6210	1527.1	4370.8	4589.4
NBT-3080	200.8	366.8	385.1	NBT-6260	1825.5	6399.1	6719.0
				NBT-6310	2106.3	8725.7	9162.0

Recirculating Ball Slide Guides

Refer to Page 84

MODEL #	M1 lb-in	M2 lb-in	M3 lb-in	MODEL #	M1 lb-in	M2 lb-in	M3 lb-in
BSGS5	16.8	10.6	13.3	BSGS9W	138.9	95.5	112.9
BSGS5UU				BSGS9WUU			
BSGS8	46.0	36.5	43.4	BSGS12W	269.1	121.5	147.6
BSGS8UU				BSGS12WUU			
BSGS10	104.2	60.8	69.5	BSGS14W	460.1	329.9	190.9
BSGS10UU				BSGS14WUU			
BSGS13	164.9	78.1	95.5	BSGS16W	1310.9	355.9	425.4
BSGS13UU				BSGS16UU			
BSGS16	355.9	190.9	225.7				
BSGS16UU							
BSGS25	868.2	451.4	538.3				
BSGS25UU							

PRICE AND ENGINEERING CHANGES:

Prices, specifications, and engineering information are subject to change without notice. All prices, dimensions, and engineering information in previous catalogs, bulletins, and price lists are superseded.

TERMS OF SALE:

All shipments are FOB our factory, Bethel, CT. Payment terms are net 30 days. Purchase orders are accepted subject only to the conditions and warranty on this page despite conditions or statements to the contrary contained in any purchase order. Risk of loss and title is with purchaser upon delivery to carrier.

Load ratings listed are based on symmetrical loading, theoretical data, and standard definitions of the bearing industry. Maximum load ratings and all other information in this catalog are suggested only, and cannot be guaranteed or warranted by Del-Tron Precision, Inc.. Suitability of the products for the intended use shall be solely determined by the user, and the user shall assume all risk and liability therewith.

DELIVERY:

Shipping dates, not delivery dates are acknowledged because we have no control over the performance of the carrier. Any extension of delivery dates beyond those specified in the original order must be approved by Del-Tron Precision, Inc.

DELAY:

Del-Tron Precision, Inc. shall not be held responsible for any delay or failure to manufacture or make delivery of all or any part of the material ordered due to strikes or other labor disputes or labor troubles, fires, floods, droughts, accidents, insurrections, breakdowns of machinery or manufacturing plant, lack of or inability to obtain raw materials, labor, power or supplies. Federal, State, County or Municipal laws, acts, rules or regulations or any other causes, contingencies or circumstances within or without the United States not subject to the control of Del-Tron Precision, Inc. which prevent or hinder the manufacture or delivery of the material ordered.

QUANTITY REDUCTION/CANCELLATION

No returns if shipment is completed. Charges will be 100% P.O. Value. If order is complete (in-house), charges will be 100% P.O. Value less shipping charges. If order is incomplete (in-house), charges will be based on Actuals: Engineering time spent, Production labor utilized, Material ordered (if special), Material used (if standard), and a 25% Administrative charge over calculated costs.

RESTOCKING CHARGE:

A 15% re-stocking charge based on value being returned, and the customer will be responsible to pay the new adjusted quantity price.

ORDER HOLDS (INITIATED BY CUSTOMER):

Time delays in shipments will require new delivery schedules to be generated, and additional set-up charges or administrative charges will be passed on to the customer.

WARRANTY, EXCLUSIVE REMEDIES & LIMITS OF LIABILITY:

Del-Tron Precision, Inc.'s ("Del-Tron") sole warranty for products is to repair and replace at no charge, products which are defective in workmanship or materials, provided written notice of such defect is supplied to Del-Tron within the warranty period and product is returned to factory without tampering or misuse. No material may be returned under warranty without prior written authorization from Del-Tron. Del-Tron shall prepay the return to purchaser of such authorized products. The warranty period is thirty (30) days after acceptance of the products. Product is deemed accepted when received by purchaser unless Del-Tron is notified in writing within thirty (30) days setting forth in detail how product does not conform to its material specifications. Del-Tron will notify purchaser when such non conformities are corrected. If, by written notice received by Del-Tron within five (5) days following Del-Tron's notification, you identify remaining non-conformities, Del-Tron will correct such non conformities. When such non-conformities are corrected, the product shall be deemed accepted. Del-Tron's liability for its product is limited to such replacement and Del-Tron shall have no liability for products mishandled or misapplied by buyer or its customers.

THE WARRANTIES SET FORTH HEREIN REPLACE ALL OTHER WARRANTIES, EXPRESS, STATUTORY OR IMPLIED, INCLUDING, BUT NOT LIMITED TO, THE IMPLIED WARRANTIES OF MERCHANTABILITY AND FITNESS FOR A PARTICULAR PURPOSE.

In all instances in which damages are sought from Del-Tron regardless of the legal theory upon which the claim is based, Del-Tron shall only be liable for (1) a bodily injury (including death) and (2) damage to real property and tangible personal property for which Del-Tron is legally liable and the amount of any other actual loss or damage arising from Del-Tron's performance or nonperformance pursuant to any Purchase up to the purchase price of the product that caused any damage. Under no circumstances will Del-Tron be liable for losses or damages resulting from third party claims against you or damages by you based upon third party claims (other than those specified in (1) and (2) above or your economic consequential damages (including loss, profits or savings)), incidental damages or punitive damages even though Del-Tron knew of their possibility.

This section sets forth a maximum collective responsibility of Del-Tron, its suppliers, subcontractors and agents, and all sets of parties are intended beneficiaries of this section. The warranty and exclusive remedy and liability limit is governed by the laws of the State of Connecticut and can not be modified or varied except in a writing signed by the purchaser and Del-Tron.





Del-Tron Precision, Inc.

“Simple — Smooth — Straight line design”

Francis J. Clarke Industrial Park
5 Trowbridge Drive, Bethel, CT, 06801

Tel: 203-778-2727

TOLL FREE: 1-800-245-5013 / FAX: 203-778-2721

WEB: www.deltron.com / E-Mail: deltron@deltron.com